

FRONTLINE® BLDG. PRODUCTS INC. PRICE CATALOG



1100 S. Huron Rd | Green Bay, WI 54311 | 920-393-1340 | Fax: 920-227-9590 | www.frontlinebldg.com

Return & Order Cancellation Policy

Returns:

In cases where material is to be returned to a FrontLine® Bldg. Products Inc. facility, an RMA (Return Material Authorization) must be issued by FrontLine® Bldg. Products Inc. prior to such return. The RMA must be signed by the customer and faxed to the FrontLine® Bldg. Products Inc. facility prior to actual return. All returns are to be sent prepaid or picked up by a FrontLine® Bldg. Products Inc. truck if within our company delivery truck boundary. ANY AND ALL material returned without proper authorization will be refused and returned freight collect.

All material to be returned to FrontLine® Bldg. Products Inc. for credit due to scratches, miscuts, etc. must have an RMA issued within a maximum of 60 days from time of shipment. This gives ample time to check all material for any defects that will require an RMA to be issued for a return to FrontLine® Bldg. Products Inc.

A 35% restocking charge will apply to any authorized stock return. Credit for all other returns will be determined at time of inspection by FrontLine® Bldg. Products Inc..

Damages:

In the event that material is damaged on any common carrier truck load or less than truckload (LTL) carrier, other than FrontLine® Bldg. Products Inc. truck, the customer must contact the carrier directly to file a claim.

If material is damaged on a FrontLine® Bldg. Products Inc. truck, a notation should be made on the driver's copy of the load ticket.

Shortages/Production Discrepancies:

In the event of material shortages, contact the FrontLine® Bldg. Products Inc. customer service department. Shortages will be replaced at no charge and normal freight prepaid. Special modes of shipment such as air freight will be the responsibility of the customer. All shortages and production discrepancies must be reported to FrontLine® Bldg. Products Inc. customer service department within three days of delivery.

Order Cancellation:

Upon a customer's request, we will cancel an order with no additional charges as long as the order has not been produced. If the order has been produced, in full or partial, or if the order is a pick and ship item that has been packaged, there will be a 35% restocking charge applied to the cancelled order.



Product Discount Schedule

| <u>Product</u> | <u>Discount Multiplier</u> Orders Picked up in Green Bay, WI | <u>Discount Multiplier</u> F.O.B. Green Bay Delivered (See Below) |
|-------------------------------|--|--|
| Pre-Clad Frames & Patio Units | _____ | _____ |
| Entry Door Clad | _____ | _____ |
| FrontLine® Composite | _____ | _____ |
| Pro Series Garage Door Frame | _____ | _____ |
| Remodel Garage Door Frame | _____ | _____ |
| Misc/Specialty Items | _____ | _____ |

In order to qualify for the delivered multiplier utilizing common carrier a **minimum aluminum order of \$3,200.00 is required in the United States and \$4,000.00 in Canada.** If your common carrier order is less than the minimum amount, your order will be invoiced at the pick up multiplier plus the common carrier charge.

PALLET CHARGES:

7'- 8' pallet \$40.00 Net
 10' - 16' pallet \$70.00 Net
 17' - 19' pallet \$100.00 Net

All orders shipped via Fed Ex, UPS, or Spee-Dee are invoiced at the delivered plus \$25.00 - \$100.00 handling charge, depending on weight and less than 96 inch length.

Any materials requested to be shipped overnight or next day air will be shipped F.O.B. Green Bay, WI.



TAB 1: ENTRY DOOR CLADDING SYSTEM

(after page 2)

Entry Door Cladding Sets

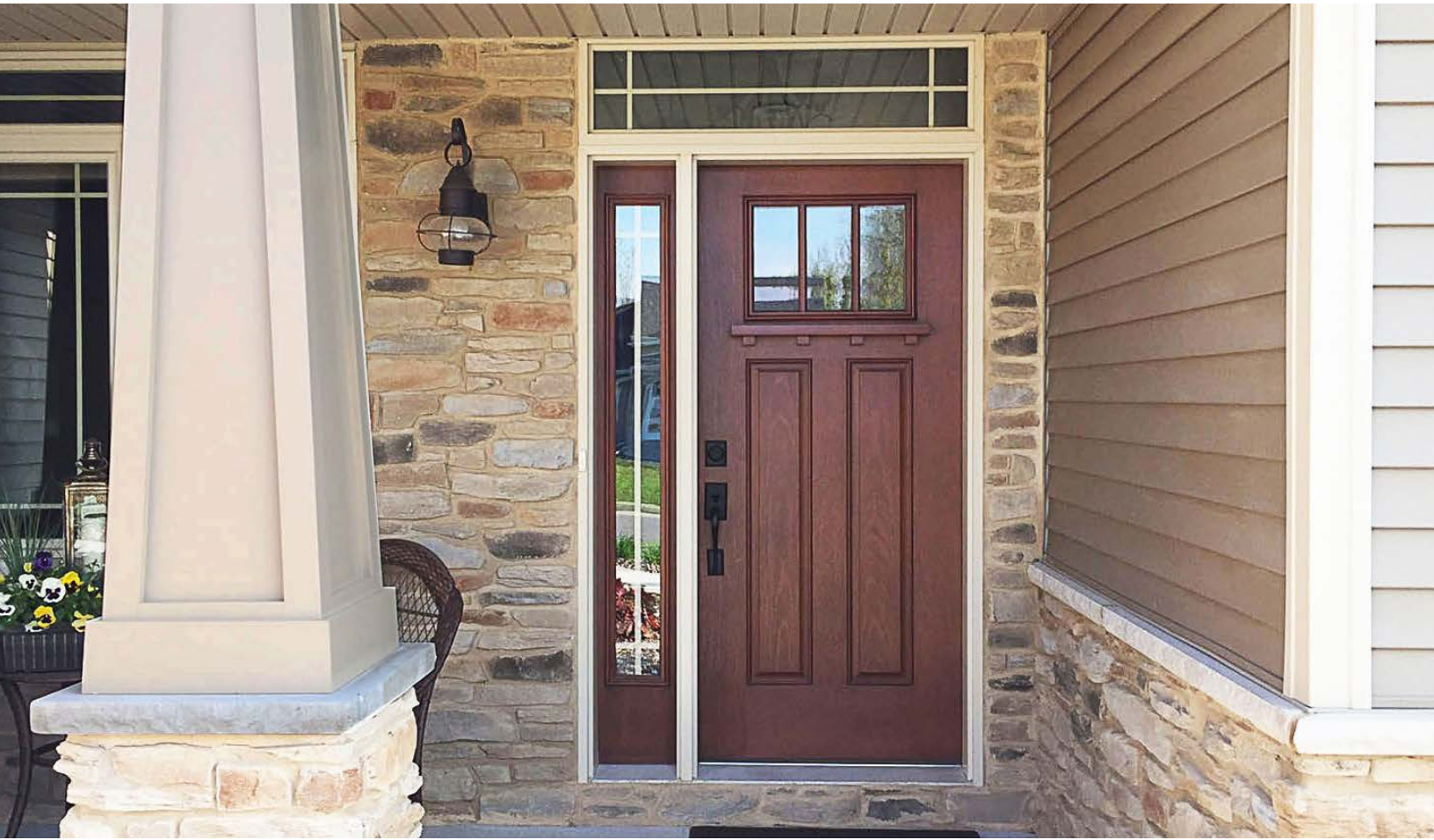

- Each set is individually packaged one frame per box
- Components for each set will be machined to individual customer frame specifications
- Each set includes: all component extrusions for cladding of a unit with screws for jamb cover & mitered corners
- Ideal for slower moving colors and configurations
- Perfect option for customers establishing a new cladding program
- Each box is custom labeled with as much or as little information as desired (i.e.: customer, job name or number, your item number or bar code)
- Labels are applied on face and end of each box
- 14 standard Colors

TAB 2: PRICING CLAD SETS

(after page 3)

Entry Door Single Clad Frame Sets

Extruded Aluminum Clad KD Kit

Single Doors for 2-6 to 3-0 units

| 6/8 Door | | | | | | |
|--------------------------------|-----------------|------------------|-------------------|---------------------------------|-----------------------|-----------------------------|
| | Slimline Nosing | Crownline Nosing | Brickmould Nosing | With Optional add on 1x4 Casing | With Optional J-Mould | With Optional 1x4 & J-Mould |
| 4-9/16" | \$279.56 | \$294.94 | \$307.90 | \$498.10 | \$395.04 | \$595.20 |
| 6-9/16" | \$357.76 | \$356.00 | \$368.96 | \$559.16 | \$456.10 | \$656.26 |
| 6-13/16" | | \$362.18 | \$375.14 | \$565.34 | \$462.30 | \$665.36 |
| *8-9/16" | | \$542.49 | \$555.47 | \$745.65 | \$652.59 | \$842.75 |
| Add Jamb Expander FLTA-75 | | \$124.96 | | | | |
| Add 2" Frame Extension FLTA-60 | | \$223.31 | | | | |
| 7/0 Door | | | | | | |
| | Slimline Nosing | Crownline Nosing | Brickmould Nosing | With Optional add on 1x4 Casing | With Optional J-Mould | With Optional 1x4 & J-Mould |
| 4-9/16" | \$312.36 | \$325.76 | \$340.16 | \$535.88 | \$429.52 | \$639.68 |
| 6-9/16" | \$399.76 | \$394.06 | \$408.48 | \$604.20 | \$497.86 | \$708.00 |
| 6-13/16" | | \$400.32 | \$414.72 | \$610.36 | \$504.12 | \$714.20 |
| *8-9/6" | | \$573.33 | \$587.67 | \$777.77 | \$677.22 | \$887.27 |
| Add Jamb Expander FLTA-75 | | \$129.84 | | | | |
| Add 2" Frame Extension FLTA-60 | | \$245.53 | | | | |
| 8/0 Door | | | | | | |
| | Slimline Nosing | Crownline Nosing | Brickmould Nosing | With Optional add on 1x4 Casing | With Optional J-Mould | With Optional 1x4 & J-Mould |
| 4-9/16" | \$345.32 | \$356.52 | \$372.52 | \$587.50 | \$471.42 | \$702.40 |
| 6-9/16" | \$442.00 | \$432.14 | \$448.16 | \$663.12 | \$547.06 | \$778.04 |
| 6-13/16" | | \$438.80 | \$454.80 | \$669.78 | \$553.70 | \$784.68 |
| *8-9/16" | | \$637.53 | \$653.55 | \$868.51 | \$752.45 | \$983.48 |
| Add Jamb Expander FLTA-75 | | \$145.36 | | | | |
| Add 2" Frame Extension FLTA-60 | | \$274.53 | | | | |

Note: Colors available on page 36

*Select Color Availability

FRAME SETS INCLUDE: Aluminum Jamb header, right and left vertical
 Nosing header, right and left vertical
 Vinyl Nail fin, fasteners for jambs and nosing.
 (Expander, casing and J-Mould if required)



Double Door Clad Frame Sets

Extruded Aluminum Clad KD Kit

Double Doors

| 6/8 Door | | | | | | |
|--------------------------------|-----------------|------------------|-------------------|---------------------------------|-----------------------|-----------------------------|
| | Slimline Nosing | Crownline Nosing | Brickmould Nosing | With Optional add on 1x4 Casing | With Optional J-Mould | With Optional 1x4 & J-Mould |
| 4-9/16" | \$345.30 | \$356.48 | \$372.48 | \$591.00 | \$473.72 | \$707.64 |
| 6-9/16" | \$441.90 | \$431.92 | \$447.90 | \$666.44 | \$548.70 | \$783.22 |
| 6-13/16" | | \$439.28 | \$455.28 | \$673.80 | \$556.08 | \$790.58 |
| *8-9/16" | | \$635.76 | \$651.78 | \$870.28 | \$752.54 | \$987.06 |
| Add Jamb Expander FLTA-75 | | \$147.88 | | | | |
| Add 2" Frame Extension FLTA-60 | | \$262.71 | | | | |
| 7/0 Door | | | | | | |
| | Slimline Nosing | Crownline Nosing | Brickmould Nosing | With Optional add on 1x4 Casing | With Optional J-Mould | With Optional 1x4 & J-Mould |
| 4-9/16" | \$378.10 | \$387.30 | \$404.72 | \$628.80 | \$507.78 | \$749.26 |
| 6-9/16" | \$483.90 | \$469.98 | \$487.42 | \$711.48 | \$590.46 | \$831.94 |
| 6-13/16" | | \$477.42 | \$494.88 | \$718.90 | \$597.88 | \$839.38 |
| *8-9/16" | | \$666.60 | \$752.38 | \$908.10 | \$787.08 | \$1,028.56 |
| Add Jamb Expander FLTA-75 | | \$152.76 | | | | |
| Add 2" Frame Extension FLTA-60 | | \$288.98 | | | | |
| 8/0 Door | | | | | | |
| | Slimline Nosing | Crownline Nosing | Brickmould Nosing | With Optional add on 1x4 Casing | With Optional J-Mould | With Optional 1x4 & J-Mould |
| 4-9/16" | \$411.06 | \$421.94 | \$437.10 | \$684.28 | \$553.54 | \$815.88 |
| 6-9/16" | \$526.14 | \$508.06 | \$527.10 | \$770.40 | \$639.64 | \$901.88 |
| 6-13/16" | | \$515.90 | \$534.94 | \$778.24 | \$647.48 | \$909.82 |
| *8-9/16" | | \$731.42 | \$750.48 | \$993.76 | \$863.00 | \$1,125.24 |
| Add Jamb Expander FLTA-75 | | \$168.24 | | | | |
| Add 2" Frame Extension FLTA-60 | | \$317.87 | | | | |

Note: Colors available on page 36
 *Select Color Availability

FRAME SETS INCLUDE: Aluminum Jamb header, right and left vertical
 Nosing header, right and left vertical
 Vinyl Nail fin, fasteners for jambs and nosing.
 (Expander, casing and J-Mould if required)



Entry Door Frame Sets

Extruded Aluminum Clad KD Kit

Single Doors with Single SideLite (3/0 Door with 12" or 14" SideLite)
2" or 2-1/2" Mull Post

| 6/8 Door | | | | | | |
|--|-----------------|------------------|-------------------|---------------------------------|-----------------------|-----------------------------|
| | Slimline Nosing | Crownline Nosing | Brickmould Nosing | With Optional add on 1x4 Casing | With Optional J-Mould | With Optional 1x4 & J-Mould |
| 4-9/16" | \$481.20 | \$508.86 | \$524.84 | \$743.38 | \$625.64 | \$860.16 |
| 6-9/16" | \$634.98 | \$646.02 | \$662.00 | \$880.54 | \$762.80 | \$997.68 |
| 6-13/16" | | \$656.36 | \$672.60 | \$894.62 | \$775.00 | \$1,013.64 |
| *8-9/16" | | \$939.42 | \$954.64 | \$1,173.94 | \$1,056.20 | \$1,291.08 |
| Add Jamb Expander FLTA-75 | | \$246.50 | | | | |
| Add 2" Frame Extension FLTA-60 | \$433.48 | | | | | |
| Add \$82.00 For 1 1/4" Spread Mull | | | | | | |
| Add \$102.00 For Universal Spread Mull. Will go up to a 4-1/2" spread. | | | | | | |
| 7/0 Door | | | | | | |
| | Slimline Nosing | Crownline Nosing | Brickmould Nosing | With Optional add on 1x4 Casing | With Optional J-Mould | With Optional 1x4 & J-Mould |
| 4-9/16" | \$529.28 | \$554.78 | \$572.20 | \$796.26 | \$754.44 | \$916.74 |
| 6-9/16" | \$699.30 | \$706.42 | \$723.86 | \$947.90 | \$826.88 | \$1,068.36 |
| 6-13/16" | | \$718.48 | \$735.44 | \$963.06 | \$840.10 | \$1,085.46 |
| *8-9/16" | | \$995.34 | \$1,011.92 | \$1,236.82 | \$1,115.80 | \$1,357.28 |
| Add Jamb Expander FLTA-75 | | \$251.38 | | | | |
| Add 2" Frame Extension FLTA-60 | \$433.48 | | | | | |
| Add \$102.00 For 1-1/4" Spread Mull | | | | | | |
| Add \$104.00 For Universal Spread Mull. Will go up to a 4-1/2" spread. | | | | | | |
| 8/0 Door | | | | | | |
| | Slimline Nosing | Crownline Nosing | Brickmould Nosing | With Optional add on 1x4 Casing | With Optional J-Mould | With Optional 1x4 & J-Mould |
| 4-9/16" | \$610.68 | \$633.98 | \$653.00 | \$896.32 | \$765.56 | \$1,027.90 |
| 6-9/16" | \$797.30 | \$800.28 | \$819.30 | \$1,062.60 | \$931.86 | \$1,194.20 |
| 6-13/16" | | \$813.08 | \$832.40 | \$1,079.60 | \$946.78 | \$1,213.30 |
| *8-9/16" | | \$1,063.64 | \$1,081.90 | \$1,325.96 | \$1,197.4 | \$1,463.86 |
| Add Jamb Expander FLTA-75 | | \$266.90 | | | | |
| Add 2" Frame Extension FLTA-60 | \$486.08 | | | | | |
| Add \$102.00 For 1-1/4" Spread Mull | | | | | | |
| Add \$194.00 For Universal Spread Mull. Will go up to a 4-1/2" spread. | | | | | | |

Note: Colors available on page 36

*Select Color Availability

SIDELITE FRAME SETS INCLUDE: Aluminum Jamb header, right and left vertical
Cladding for complete mull
Nosing header, right and left vertical
Vinyl Nailfin, fasteners for jambs and nosing.
(Expander, casing and J-Mould if required)



Entry Door Frame Sets

Extruded Aluminum Clad KD Kit

Single Doors with Double SideLite (3/0 Door with two 12" or 14" SideLites) 2" or 2-1/2" Mull Post

| 6/8 Door | | | | | | |
|--|-----------------|------------------|-------------------|---------------------------------|-----------------------|-----------------------------|
| | Slimline Nosing | Crownline Nosing | Brickmould Nosing | With Optional add on 1x4 Casing | With Optional J-Mould | With Optional 1x4 & J-Mould |
| 4-9/16" | \$650.10 | \$676.66 | \$693.36 | \$921.62 | \$799.00 | \$1043.96 |
| 6-9/16" | \$870.14 | \$870.14 | \$879.16 | \$1,115.10 | \$1,001.50 | \$1,246.48 |
| 6-13/16" | | \$884.06 | \$893.22 | \$1,132.94 | \$1,017.52 | \$1,266.42 |
| *8-9/16" | | \$1,324.08 | \$1,340.10 | \$1,572.96 | \$1,457.54 | \$1,706.44 |
| Add Jamb Expander FLTA-75 | | \$345.00 | | | | |
| Add 2" Frame Extension FLTA-60 | | \$630.57 | | | | |
| Add \$168.00 For 1 1/4" Spread Mull | | | | | | |
| Add \$204.00 For Universal Spread Mull. Will go up to a 4-1/2" spread. | | | | | | |
| 7/0 Door | | | | | | |
| | Slimline Nosing | Crownline Nosing | Brickmould Nosing | With Optional add on 1x4 Casing | With Optional J-Mould | With Optional 1x4 & J-Mould |
| 4-9/16" | \$713.06 | \$713.22 | \$731.92 | \$947.72 | \$821.80 | \$1,073.74 |
| 6-9/16" | \$956.78 | \$920.06 | \$938.20 | \$1,172.00 | \$1,046.08 | \$1,298.02 |
| 6-13/16" | | \$934.78 | \$953.22 | \$1,190.76 | \$1,062.82 | \$1,318.78 |
| *8-9/16" | | \$1,385.08 | \$1,402.46 | \$1,641.06 | \$1,513.12 | \$1,769.08 |
| Add Jamb Expander FLTA-75 | | \$349.88 | | | | |
| Add 2" Frame Extension FLTA-60 | | \$630.51 | | | | |
| Add \$204.00 For 1-1/4" Spread Mull | | | | | | |
| Add \$208.00 For Universal Spread Mull. Will go up to a 4-1/2" spread. | | | | | | |
| 8/0 Door | | | | | | |
| | Slimline Nosing | Crownline Nosing | Brickmould Nosing | With Optional add on 1x4 Casing | With Optional J-Mould | With Optional 1x4 & J-Mould |
| 4-9/16" | \$842.90 | \$790.12 | \$809.88 | \$1062.92 | \$927.28 | \$1200.06 |
| 6-9/16" | \$1110.54 | \$1,038.34 | \$1,056.30 | \$1,308.14 | \$1,173.50 | \$1,446.28 |
| 6-13/16" | | \$1,054.96 | \$1,073.20 | \$1,329.06 | \$1,192.28 | \$1,469.42 |
| *8-9/16" | | \$1,552.58 | \$1,571.64 | \$1,822.38 | \$1,687.74 | \$1,967.04 |
| Add Jamb Expander FLTA-75 | | \$365.40 | | | | |
| Add 2" Frame Extension FLTA-60 | | \$709.29 | | | | |
| Add \$204.00 For 1-1/4" Spread Mull | | | | | | |
| Add \$428.00 For Universal Spread Mull. Will go up to a 4-1/2" spread. | | | | | | |

Note: Colors available on page 36
*Select Color Availability

SIDELITE FRAME SETS INCLUDE: Aluminum Jamb header, right and left vertical
Cladding for complete mull
Nosing header, right and left vertical
Vinyl Nailfin, fasteners for jambs and nosing.
(Expander, casing and J-Mould if required)



Rectangular Jamb Clad Transoms

Transoms are sold by the total lineal foot. (All lengths are priced to the next nearest foot) EXAMPLE = 6' header is priced out as 7' due to scrap factor.

EXAMPLE = 72" X 12" transom is a total of 16' of material. (Specialty machining charges may apply)

The following prices are to be added to door unit pricing for including transom.

| | |
|---|---------|
| Brickmould with a 4-9/16" Jamb Cover | \$15.24 |
| Brickmould with a 6-9/16" Jamb Cover (Nailing Fin - Optional) | \$18.64 |
| Crownline with 4-9/16" Jamb Cover | \$15.24 |
| Crownline with optional J-Mould and 4-9/16" Jamb Cover | \$20.02 |
| Crownline with 6-9/16" Jamb Cover | \$17.92 |
| Crownline with J-Mould and 6-9/16" Jamb Cover | \$23.42 |
| Crownline with 3-1/2" Casing and 4-9/16" Jamb Cover | \$24.94 |
| Crownline with 3-1/2" Casing and 6-9/16" Jamb Cover | \$28.34 |
| Crownline with 3-1/2" Casing and J-Mould and 4-9/16" Jamb Cover | \$30.44 |
| Crownline with 3-1/2" Casing and J-Mould and 6-9/16" Jamb Cover (Nailing Fin - required) | \$33.84 |
| SlimLine with a 4-9/16" Jamb Cover | \$15.52 |
| SlimLine with a 6-9/16" Jamb Cover | \$16.90 |

Additional jamb depths require the addition of jamb extenders.

**Pre-Built transoms available through our FrontLine® Medford location.
Please contact them at 800-223-4792 or via email salesmedford@frontlinebldg.com**



(after page 8)

TAB 3: CLAD TRANSOMS

INSERT CLAD TRANSOM / FLTA-76 BROCHURE AFTER TAB

CLAD TRANSOMS

THE PERFECT SOLUTION FOR YOUR FRONTLINE®
CLAD ENTRY SYSTEM.

FrontLine Building Products' transoms are focused on engineering and quality for function, fit and finish for our entry door clad systems. Designed and engineered to work together.



Transoms

- F.I.T.™ Transoms
- FLTA-76 Transom
- Primed transoms

Available in all common shapes and sizes

Glass options

- Complete decorative and clear glass program
- Grilles
- SDL – Wood or aluminum
- GBG

Additional Features

- 14 standard colors (FLTA-76, 5 colors: White, Sandstone, Bronze, Terratone, Black & Primed)
- Custom colors
- Custom jamb depths

Exterior casing profiles

- Crownline
- Brickmould
- Slimline

Jamb options

- Composite
- Primed
- Pine
- Oak
- Fir
- Mahogany
- Maple
- Cherry
- Knotty alder
- Special order

FrontLine's Interlock Technology

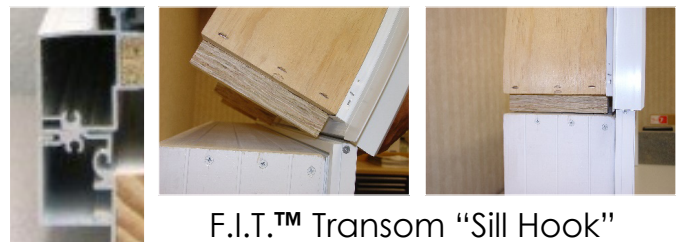

F.I.T.™ Transom "Sill Hook"

At FrontLine, we design our transoms with a glass forward design, keeping the transom glass to the exterior plane of the home to be consistent with the window design.

See our website for warranty information.



FrontLine®
Bldg. Products Inc.

Member of the Bay Family of Companies

www.frontlinebldg.com | Medford | salesmedford@frontlinebldg.com | 715-748-2288

FLTA-76 Transom Glazing Leg

| Features & Benefits | |
|--|--------------------------------------|
| Features | Benefits |
| Designed for shop build | Shorter lead-times |
| Glass forward design | Eliminates the shelf to the exterior |
| Interchangeable exterior casing options | Meet architectural details |
| Continuous vertical exterior casing, from sill to top of transom | Clean sight lines |
| No spread mull between door and transom | Narrow mull to interior/exterior |

The FLTA-76 Transom Glazing Leg was designed with our fabricating partners in mind, assisting the fabricator with:

- Flexibility
 - Easy shop build
 - Manufactured transoms by our Medford division
 - Open
 - Glazed
- Function
 - Designed for clean sight lines
 - Narrow mull application
 - More daylight opening while maintaining your rough opening
 - Shop built with glass forward design
 - Engineered to work in unison with all of FrontLine's cladding components
- Reducing material cost
- Reducing labor cost
- Reducing call backs
- Eliminating the "catch all" ledge
 - Snow and Ice build up
 - Dirt and debris build up
 - Bird nests
- Improving margins
- Providing a better quality door system with clean sight lines



DISTRIBUTED BY:



www.frontlinebldg.com | Green Bay | sales@frontlinebldg.com | 920-393-1340

(after page 10)

TAB 4: PRE-CLAD FRAMES

INSERT PRE-CLAD BROCHURE AFTER TAB

PRE-CLAD DOOR FRAMES

FRONTLINE® COMPOSITE OR TRUCORE® PINE
THE COMPLETE FRAME SOLUTION



FrontLine®
Bldg. Products Inc.
Member of the Bay Family of Companies

PreClad Frames by Frontline® offer a one-step assembly that features a 16 gauge prefinished aluminum exterior integrated with a FrontLine® Composite or TruCore® treated pine base. Use our standard 4-9/16" or 6-9/16" frames, or custom-size your frames using Frontline® extrusions. Add brickmould and crownline nosings and five standard colors – white, black, bronze, sandstone and terratone – and you will have door frames for nearly any application.



FRAME SPECIFICATIONS

- **Base** - Composite: Woodgrain or primed
Pine: Finger-jointed clear or primed
- **Aluminum** - 16 gauge
- **Paint** - To AAMA 2603 standard
- **Frame Widths** - Standard: 4-9/16" and 6-9/16"
Fabricated: 4-9/16" to 12-9/16"
- **Mull Posts** - 2-1/2" and "back-to-back"
- **Casing** - Brickmould, Crownline, Flat Casing

FRAME DETAILS

- **Sidelite Systems** - Continuous head & sill
Box units
- **Frame Specs** - Match your wood frame specs
- **Frame Preps** - Sill angle, head dado, mull headers, mull
haunch, hinges & deadbolts
- **Weather-Seal** - Installed, loose or none
Q-Ion 650 or 730
Beige, black, bronze or white
- **Variable Depths** - FLTA-77 for ripped frames
FLTA-60 - 2" Frame Extender

FRAME FEATURES

- **Assembles the same as a wood frame:**
Cuts clad unit assemble time in half
- **Custom Frame Depth:**
Fabricate the jamb depth you need
- **Composite Base:**
Rot, decay, mold, insect and split proof
Woodgrain - stains like a fiberglass door or
paint Prime - paint
- **TruCore Pine Base:**
Rot, decay, mold, insects and split resistant
clear or primed - treated for life
- **Storm Door Compatible**
- **16 Gauge Aluminum Exterior**
Heavy-duty and dent resistant
- **Limited Lifetime Warranty**
See FrontLine® website for complete
information
- **Transom Compatible:**
Complete selection available - see
website



www.frontlinebldg.com | sales@frontlinebldg.com | 920-393-1340

©2021 FrontLine® Bldg. Products Inc.
Patent #
US7,111,433 | US7,454,865 | CA2,415,545

SC/PCDF/SS250/1119IH

Pre-Clad Frame With FrontLine® Primed Composite Frame Components

FRAMES

Machining included as detailed below:

| | Qty 1-5 | Qty 6-11 | Qty 12-19 | Qty 20+ |
|--------------|--------------------------------------|----------|-----------|---------|
| Parts | Does Not Include Weatherstrip | | | |

4-9/16" Frame (FLTA-74)

| Headers | | | | |
|-----------|----------|----------|----------|----------|
| 3/0 | \$51.73 | \$41.38 | \$39.51 | \$37.62 |
| 6/0 | \$101.68 | \$81.28 | \$77.58 | \$73.90 |
| Verticals | | | | |
| 6/8 | \$101.60 | \$81.28 | \$77.58 | \$73.90 |
| 7/0 | \$122.96 | \$98.36 | \$93.68 | \$89.22 |
| 8/0 | \$160.28 | \$128.22 | \$122.12 | \$116.30 |

6-9/16" Frame (FLTA-73)

| Headers | | | | |
|-----------|----------|----------|----------|----------|
| 3/0 | \$81.07 | \$64.85 | \$61.90 | \$58.95 |
| 6/0 | \$167.65 | \$134.12 | \$128.03 | \$121.93 |
| Verticals | | | | |
| 6/8 | \$167.65 | \$134.12 | \$128.03 | \$121.93 |
| 7/0 | \$181.20 | \$144.96 | \$138.06 | \$131.48 |
| 8/0 | \$243.58 | \$187.66 | \$178.72 | \$170.20 |

VERTICALS MUST BE ORDERED AS LEFTS ONLY OR RIGHTS ONLY TO OBTAIN MINIMUM QUANTITY PRICING.

CANNOT MIX MACHINING OPTIONS TO OBTAIN MINIMUM QUANTITY PRICING

Example correct order method: (20 right vertical w/ hinge only, 20 right vertical latch only, 20 left vertical latch and deadbolt)

CAN MIX COLORS TO OBTAIN MINIMUM QUANTITY PRICING
Available in White, Sandstone, Bronze, Terratone and Black

INCLUDES:
JAMBS - 3 HINGE ROUT • STRIKE ROUT • STRIKE/DEADBOLT ROUT • MACHINED SILL ANGLE CUT TO LENGTH PER CUSTOMER SPECIFICATIONS

HEADER - CUT TO LENGTH PER CUSTOMER SPECIFICATION

WEATHERSTRIP ADD ON: 3/0 Inserted \$4.26
 6/8 Inserted \$8.18
 8/0 Inserted \$10.18

DEDUCTIONS:
NO MACHINING OF HINGES/ STRIKE / STRIKE-DEADBOLT - DEDUCT \$2.78 LIST EACH JAMB

NOTE: NOSING AND NAIL FIN SOLD SEPARATELY



Pre-Clad Frame With FrontLine® Primed Composite Sidelite Header and Mull Post Components

SIDELITE HEADER

Machining included as detailed below:

| | Quantity 1-5 | Quantity 6+ |
|--------------------------------|--------------------------------------|-------------|
| Parts | Does Not Include Weatherstrip | |
| 4-9/16" Frame (FLTA-74) | | |
| 1 Sidelite | | |
| 3/0 | \$71.85 | \$65.33 |
| 2 Sidelites | | |
| 3/0 | \$82.46 | \$74.97 |
| 6-9/16" Frame (FLTA-73) | | |
| 1 Sidelite | | |
| 3/0 | \$104.25 | \$94.78 |
| 2 Sidelites | | |
| 3/0 | \$120.62 | \$109.66 |

SPECIFY IF SIDELITE IS LEFT OR RIGHT OF DOOR (OSLI)

HEADERS MUST BE ORDERED AS SIDELITE RIGHT ONLY OR SIDELITE LEFT ONLY
TO OBTAIN MINIMUM QUANTITY PRICING.

MULL POST

| | Quantity 1-5 | Quantity 6+ |
|---------------------------------------|--------------------------------------|-------------|
| Parts | Does Not Include Weatherstrip | |
| 2.5" X 4-9/16" Frame (FLTA-74) | | |
| 6/8 | \$279.36 | \$253.96 |
| 7/0 | \$301.70 | \$274.28 |
| 8/0 | \$356.10 | \$323.66 |
| 2.5" X 6-9/16" Frame (FLTA-73) | | |
| 6/8 | \$334.60 | \$304.22 |
| 7/0 | \$361.46 | \$328.60 |
| 8/0 | \$415.70 | \$377.90 |

ADDERS:

| | | |
|-------------------|--|------------------------------|
| Machining Adders: | Rout For Strike Prep | <u>LIST</u> \$2.78 |
| | Rout For Deadbolt Prep | \$2.78 |
| | Rout For Hinge Prep (3) on 6/8 and 7/0 | \$2.78 |
| | Rout For Hinge Prep (4) on 8/0 | \$5.00 |
| | Sill Haunch | \$25.00 |

| | | |
|------------------------------------|--------------|---------|
| <u>WEATHERSTRIP ADD ON:</u> | 3/0 Inserted | \$4.26 |
| | 6/8 Inserted | \$8.18 |
| | 8/0 Inserted | \$10.18 |

INCLUDES:

CUT TO CUSTOMER SPECIFICATION



Pre-Clad Frame With FrontLine® Woodgrain Composite Frame Components

FRAMES

Machining included as detailed below:

| | | | | |
|--------------|--------------------------------------|----------|-----------|---------|
| | Qty 1-5 | Qty 6-11 | Qty 12-19 | Qty 20+ |
| Parts | Does Not Include Weatherstrip | | | |

4-9/16" Frame (FLTA-74)

| Headers | | | | |
|-----------|----------|----------|----------|----------|
| 3/0 | \$58.48 | \$46.78 | \$45.12 | \$43.44 |
| 6/0 | \$114.10 | \$91.28 | \$87.58 | \$83.90 |
| Verticals | | | | |
| 6/8 | \$114.10 | \$91.28 | \$87.58 | \$83.90 |
| 7/0 | \$135.46 | \$108.36 | \$103.68 | \$99.22 |
| 8/0 | \$172.78 | \$138.22 | \$132.12 | \$126.30 |

6-9/16" Frame (FLTA-73)

| Headers | | | | |
|-----------|----------|----------|----------|----------|
| 3/0 | \$77.39 | \$61.88 | \$59.52 | \$57.16 |
| 6/0 | \$161.52 | \$129.22 | \$123.80 | \$118.38 |
| Verticals | | | | |
| 6/8 | \$161.52 | \$129.22 | \$123.80 | \$118.38 |
| 7/0 | \$193.70 | \$154.96 | \$148.06 | \$141.48 |
| 8/0 | \$247.08 | \$197.66 | \$188.72 | \$180.20 |

**VERTICALS MUST BE ORDERED AS LEFTS ONLY OR RIGHTS ONLY
TO OBTAIN MINIMUM QUANTITY PRICING.**

CANNOT MIX MACHINING OPTIONS TO OBTAIN MINIMUM QUANTITY PRICING

Example correct order method:

(20 right vertical w/ hinge only, 20 right vertical latch only, 20 left vertical latch and deadbolt)

**CAN MIX COLORS TO OBTAIN MINIMUM QUANTITY PRICING
Available in White, Sandstone, Bronze, Terratone and Black**

INCLUDES:

JAMBS - 3 HINGE ROUT * STRIKE ROUT * STRIKE/DEADBOLT ROUT * MACHINED SILL ANGLE
CUT TO LENGTH PER CUSTOMER SPECIFICATIONS

HEADER - CUT TO LENGTH PER CUSTOMER SPECIFICATION

WEATHERSTRIP ADD ON: 3/0 Inserted \$4.26
 6/8 Inserted \$8.18
 8/0 Inserted \$10.18

DEDUCTIONS:

NO MACHINING OF HINGES/ STRIKE / STRIKE-DEADBOLT - DEDUCT \$2.78 LIST EACH JAMB

NOTE: NOSING AND NAIL FIN SOLD SEPARATELY



Pre-Clad Frame With FrontLine® Woodgrain Composite Sidelite Header and Mull Post Components

SIDELITE HEADER

Machining included as detailed below:

| | Quantity 1-5 | Quantity 6+ |
|--------------------------------|--------------------------------------|-------------|
| Parts | Does Not Include Weatherstrip | |
| 4-9/16" Frame (FLTA-74) | | |
| | 1 Sidelite | |
| 3/0 | \$64.67 | \$58.79 |
| | 2 Sidelites | |
| 3/0 | \$82.46 | \$74.97 |
| 6-9/16" Frame (FLTA-73) | | |
| | 1 Sidelite | |
| 3/0 | \$104.25 | \$94.78 |
| | 2 Sidelites | |
| 3/0 | \$120.62 | \$109.66 |

SPECIFY IF SIDELITE IS LEFT OR RIGHT OF DOOR (OSLI)
HEADERS MUST BE ORDERED AS SIDELITE RIGHT ONLY OR SIDELITE LEFT ONLY
TO OBTAIN MINIMUM QUANTITY PRICING.

MULL POST

| | Quantity 1-5 | Quantity 6+ |
|--------------------------------|--------------------------------------|-------------|
| Parts | Does Not Include Weatherstrip | |
| 4-9/16" Frame (FLTA-74) | | |
| 6/8 | \$299.36 | \$273.96 |
| 7/0 | \$321.70 | \$294.28 |
| 8/0 | \$376.10 | \$343.66 |
| 6-9/16" Frame (FLTA-73) | | |
| 6/8 | \$354.64 | \$324.22 |
| 7/0 | \$381.46 | \$348.60 |
| 8/0 | \$435.70 | \$397.90 |

ADDERS:

| | | |
|-------------------|--|---------|
| Machining Adders: | Rout For Strike Prep | \$2.78 |
| | Rout For Deadbolt Prep | \$2.78 |
| | Rout For Hinge Prep (3) on 6/8 and 7/0 | \$2.78 |
| | Rout For Hinge Prep (4) on 8/0 | \$5.00 |
| | Sill Haunch | \$25.00 |

LIST

| | | |
|------------------------------------|--------------|---------|
| <u>WEATHERSTRIP ADD ON:</u> | 3/0 Inserted | \$4.26 |
| | 6/8 Inserted | \$8.18 |
| | 8/0 Inserted | \$10.18 |

CAN MIX COLORS TO OBTAIN MINIMUM QUANTITY PRICING
Available in White, Sandstone, Bronze, Terratone and Black

INCLUDES:

CUT TO CUSTOMER SPECIFICATION



Pre-Clad Frame With TRU-CORE® Treated Wood Frame Components

FRAMES

Machining included as detailed below:

| | Qty 1-5 | Qty 6-11 | Qty 12-19 | Qty 20+ |
|--------------|--------------------------------------|----------|-----------|---------|
| Parts | Does Not Include Weatherstrip | | | |

4-9/16" Frame (FLTA-74)

| Headers | | | | |
|-----------|----------|----------|----------|----------|
| 3/0 | \$56.80 | \$45.44 | \$43.28 | \$41.22 |
| 6/0 | \$110.76 | \$88.60 | \$84.38 | \$80.36 |
| Verticals | | | | |
| 6/8 | \$110.76 | \$88.60 | \$84.38 | \$80.36 |
| 7/0 | \$133.22 | \$106.58 | \$101.50 | \$96.68 |
| 8/0 | \$176.26 | \$141.00 | \$134.42 | \$128.14 |

6-9/16" Frame (FLTA-73)

| Headers | | | | |
|-----------|----------|----------|----------|----------|
| 3/0 | \$83.60 | \$66.88 | \$63.70 | \$60.66 |
| 6/0 | \$161.72 | \$129.38 | \$123.22 | \$117.32 |
| Verticals | | | | |
| 6/8 | \$161.72 | \$129.38 | \$123.22 | \$117.32 |
| 7/0 | \$195.30 | \$156.24 | \$148.80 | \$141.70 |
| 8/0 | \$257.06 | \$205.64 | \$195.98 | \$186.76 |

6-11/16 TRU-CORE® Pre-Clad

| Headers | | | | |
|-----------|----------|----------|----------|----------|
| 3/0 | \$90.60 | \$73.88 | \$70.70 | \$67.66 |
| 6/0 | \$168.72 | \$136.38 | \$130.22 | \$124.32 |
| Verticals | | | | |
| 6/8 | \$168.72 | \$136.38 | \$130.22 | \$124.32 |
| 7/0 | \$202.30 | \$163.24 | \$155.80 | \$148.70 |
| 8/0 | \$264.06 | \$212.64 | \$202.64 | \$193.76 |

VERTICALS MUST BE ORDERED AS LEFTS ONLY OR RIGHTS ONLY TO OBTAIN MINIMUM QUANTITY PRICING.

CANNOT MIX MACHINING OPTIONS TO OBTAIN MINIMUM QUANTITY PRICING

Example correct order method: (20 right vertical w/ hinge only, 20 right vertical latch only, 20 left vertical latch and deadbolt)

CAN MIX COLORS TO OBTAIN MINIMUM QUANTITY PRICING

Available in White, Sandstone, Bronze, Terratone and Black

INCLUDES:

JAMBS - 3 HINGE ROUT • STRIKE ROUT • STRIKE/DEADBOLT ROUT • MACHINED SILL ANGLE CUT TO LENGTH PER CUSTOMER SPECIFICATIONS

HEADER - CUT TO LENGTH PER CUSTOMER SPECIFICATION

| | | |
|------------------------------------|--------------|---------|
| <u>WEATHERSTRIP ADD ON:</u> | 3/0 Inserted | \$4.26 |
| | 6/8 Inserted | \$8.18 |
| | 8/0 Inserted | \$10.18 |

ADDERS:

| | <u>LIST</u> |
|---------------------------|--------------|
| Primed Material: | Jambs \$3.04 |
| | Heads \$3.04 |
| ADA Sill Wood Filler-Jamb | \$20.00 |

DEDUCTIONS:

NO MACHINING OF HINGES/ STRIKE / STRIKE-DEADBOLT
DEDUCT \$2.78 LIST EACH JAMB

NOTE: NOSING AND NAIL FIN SOLD SEPARATELY



Pre-Clad Frame With TRU-CORE® Treated Wood Sidelite Header and Mull Post Components

SIDELITE HEADER

Machining included as detailed below:

| | Quantity 1-5 | Quantity 6+ |
|-------|--------------------------------------|-------------|
| Parts | Does Not Include Weatherstrip | |

4-9/16" Frame (FLTA-74)

| 1 Sidelite | | |
|-------------|---------|---------|
| 3/0 | \$75.84 | \$69.04 |
| 2 Sidelites | | |
| 3/0 | \$97.80 | \$88.90 |

6-9/16" Frame (FLTA-73)

| 1 Sidelite | | |
|-------------|----------|----------|
| 3/0 | \$114.44 | \$104.04 |
| 2 Sidelites | | |
| 3/0 | \$138.64 | \$126.04 |

6-11/16 TRU-CORE® Pre-Clad

| 1 Sidelite | | |
|-------------|----------|----------|
| 3/0 | \$121.44 | \$111.04 |
| 2 Sidelites | | |
| 3/0 | \$145.64 | \$133.04 |

SPECIFY IF SIDELITE IS LEFT OR RIGHT OF DOOR (OSLI)

HEADERS MUST BE ORDERED AS SIDELITE RIGHT ONLY OR SIDELITE LEFT ONLY TO OBTAIN MINIMUM QUANTITY PRICING.

MULL POST

| | Quantity 1-5 | Quantity 6+ |
|-------|--------------------------------------|-------------|
| Parts | Does Not Include Weatherstrip | |

4-9/16" Frame (FLTA-74)

| | | |
|-----|----------|----------|
| 6/8 | \$316.22 | \$287.48 |
| 7/0 | \$343.04 | \$311.86 |
| 8/0 | \$402.82 | \$366.20 |

6-9/16" Frame (FLTA-73)

| | | |
|-----|----------|----------|
| 6/8 | \$441.52 | \$401.38 |
| 7/0 | \$464.04 | \$421.86 |
| 8/0 | \$521.70 | \$474.28 |

6-11/16 TRU-CORE® Pre-Clad

| | | |
|-----|----------|----------|
| 6/8 | \$455.52 | \$415.38 |
| 7/0 | \$478.04 | \$435.86 |
| 8/0 | \$535.70 | \$488.28 |

ADDERS:

| | | |
|-------------------|--|-----------------------|
| Primed Material: | Heads | <u>LIST</u> \$3.04 |
| | Mull Post | \$6.08 |
| Machining Adders: | Rout For Strike Prep | \$2.78 |
| | Rout For Deadbolt Prep | \$2.78 |
| | Rout For Hinge Prep (3) on 6/8 and 7/0 | \$2.78 |
| | Rout For Hinge Prep (4) on 8/0 | \$5.00 |
| | Sill Haunch | \$25.00 |

WEATHERSTRIP ADD ON:

| | |
|--------------|---------|
| 3/0 Inserted | \$4.26 |
| 6/8 Inserted | \$8.18 |
| 8/0 Inserted | \$10.18 |

INCLUDES:

CUT TO LENGTH PER CUSTOMER SPECIFICATION

CAN MIX COLORS TO OBTAIN MINIMUM QUANTITY PRICING
Available in White, Sandstone, Bronze, Terratone and Black



Pre-Clad Components Variable Depth Expander

| | Quantity 1-9 | Quantity 20+ | Lineal Length Each |
|--|---------------|---------------|--------------------|
| Parts | Standard Size | Standard Size | Standard Size |
| Variable Depth Expander (FLTA-77) | | | |
| | 7/0 \$40.46 | 7/0 \$38.44 | 14' 0" \$66.88 |

CAN MIX COLORS TO OBTAIN MINIMUM QUANTITY PRICING
Available in White, Sandstone, Bronze, Terratone and Black



FRONTLINE® BLDG. PRODUCTS INC.
PRE-CLAD EXTERIOR RESIDENTIAL ENTRY DOOR FRAME
LIMITED WARRANTY

Frontline® Bldg. Products Inc. warrants that, if installed in accordance with industry standards, guidelines, and local industry codes, its PRE-CLAD Wood TRU-CORE® / Aluminum or Composite / Aluminum Exterior Residential Door Frame Components, Mull Posts, and attaching aluminum exterior trim profiles (its "PRE-CLAD" Door Frame Product) will be free from manufacturing defects in materials and workmanship, as follows:

A. Lifetime Limited Warranty to Original Homeowner for Water Damage. Frame Components of PRE-CLAD Door Frame Product shall be free from water damage caused by water absorbing into the wood TRU-CORE® or Composite portion of said frame, at the sill line, in the original point of installation, as follows: this Limited Warranty is available, without registration, to the person who is the owner of the residential home at the time the PRE-CLAD Door Frame Product is first installed (the "Original Homeowner") for as long as the PRE-CLAD Door Frame Product is owned by the Original Homeowner. This Limited Warranty may be transferred to a subsequent owner (a "Subsequent Owner") subject to the following: all time periods for the Limited Warranty contained herein to the Original Homeowner shall be limited to a Subsequent Owner for a period of 90 days from the date of transfer by the Original Homeowner to a Subsequent Owner.

B. One-Year Limited Warranty to First Purchaser of Other Defects. PRE-CLAD Door Frame Product shall be free from manufacturing defects in materials and workmanship, not related to water damage, as follows: this Limited Warranty is available to the Original Homeowner, without registration, for a period of one year from the date of manufacture of the PRE-CLAD Door Frame Product. This Limited Warranty may be transferred to a Subsequent Owner, subject to the following: all time periods for the Limited Warranty contained herein to the Original Homeowner shall be limited to the lesser of 90 days from the date of transfer by the Original Homeowner to a Subsequent Owner, or for a period of one year from the date of manufacture of the PRE-CLAD Door Frame Product, whichever is less.

All warranties provided by component manufacturers, if any, are hereby assigned to the Original Homeowner who purchases PRE-CLAD Door Frame Product.

If the PRE-CLAD Door Frame Product is determined to be defective during the warranted period, as defined, above, the sole and exclusive remedy to the Original Homeowner or the Subsequent Owner is that FrontLine® Bldg. Products Inc. will, at its own option:

- Repair the defective product;
- Provide replacement product for the defective product;
- Refund purchase price of the defective product; or,
- Reimburse the costs for repair of, or provision of replacement product for, the defective product.
- If FrontLine® Bldg. Products Inc. elects to provide replacement product for the defective product, or to provide reimbursement of the costs for repair of, or replacement product for the defective product, FrontLine® Bldg. Products Inc. will not be responsible for any costs of shipping, handling, installation, removal, reinstallation, labor, finish painting, or other incidentals related to the new or the defective product.



LIMITATIONS: FrontLine® Bldg. Products Inc. will not be liable for, and none of the above warranties apply to or cover problems, costs or losses caused by, arising from, or related to, any of the following:

- Improper installation
- Improper maintenance
- Misuse or abuse
- Normal wear and tear
- Decay or rot due to allowable "ponding"
- Installation directly over concrete floor, or in any other high moisture areas
- Installation in commercial applications
- Warping or twisting
- If component has been trimmed or modified
- Natural disasters (flood, hurricane, typhoon, tornado, or other natural disaster not specifically listed here)

IN NO EVENT SHALL FRONTLINE® BLDG. PRODUCTS INC. BE LIABLE FOR ANY DIRECT, INDIRECT, SPECIAL, INCIDENTAL OR CONSEQUENTIAL DAMAGES OR LOSSES, INCLUDING, WITHOUT LIMITATION, COSTS OF SHIPPING, HANDLING, INSTALLATION, REMOVAL, REINSTALLATION, OR FINISH PAINTING, ETC. IN NO EVENT SHALL THE AMOUNT DUE HEREUNDER BE IN EXCESS OF THE DEFECTIVE UNIT'S PURCHASE PRICE, WHETHER THE CLAIM IS FOR BREACH OF WARRANTY OR NEGLIGENCE OR OTHERWISE. SOME STATES DO NOT ALLOW FOR THE EXCLUSION OR LIMITATIONS OF INCIDENTAL, CONSEQUENTIAL OR INDIRECT DAMAGES OR LOSSES, SO THIS LIMITATION MAY NOT APPLY TO YOU.

TO THE MAXIMUM EXTENT ALLOWED BY THE LAW, THE EXPRESS WARRANTIES SET FORTH HEREIN ARE IN LIEU OF ALL OTHER IMPLIED WARRANTIES OF ANY KIND (EXCEPT THE IMPLIED WARRANTY OF TITLE), INCLUDING BUT NOT LIMITED TO IMPLIED WARRANTIES OF MERCHANTABILITY OR FITNESS FOR A PARTICULAR PURPOSE OR USE, AND ALL SUCH IMPLIED WARRANTIES ARE HEREBY DISCLAIMED AND EXCLUDED BY FRONTLINE® BLDG. PRODUCTS INC. THE DURATION AND TERMS OF ANY IMPLIED WARRANTY THAT IS NOT EFFECTIVELY DISCLAIMED BY THIS PARAGRAPH SHALL BE THE SAME AS THE DURATION AND TERMS OF FRONTLINE® BLDG. PRODUCTS INC.'S EXPRESS WARRANTIES DISCUSSED ABOVE. HOWEVER, SOME STATES DO NOT ALLOW LIMITATIONS ON HOW LONG AN IMPLIED WARRANTY LASTS, SO THE ABOVE LIMITATION MAY NOT APPLY TO YOU.

NO ONE IS AUTHORIZED TO EXPAND OR CHANGE THESE WRITTEN WARRANTIES

CLAIMS PROCEDURE: Any and all warranty claims must be made to the dealer from whom the product was originally purchased and must be supported by proof of purchase, a written description of the claimed defect, and a photograph of the claimed defect. Do not contact Frontline® Bldg. Products Inc. directly with regard to warranty claims.

Effective 12/27/2016



TAB 5: PRICING PATIO DOOR FRAMES
(after page 21)

Pre-Clad Patio Door Frame with Screen and Screen Track

On Primed Composite Frame | Kit Package or Tru-Core Pine

Order Code

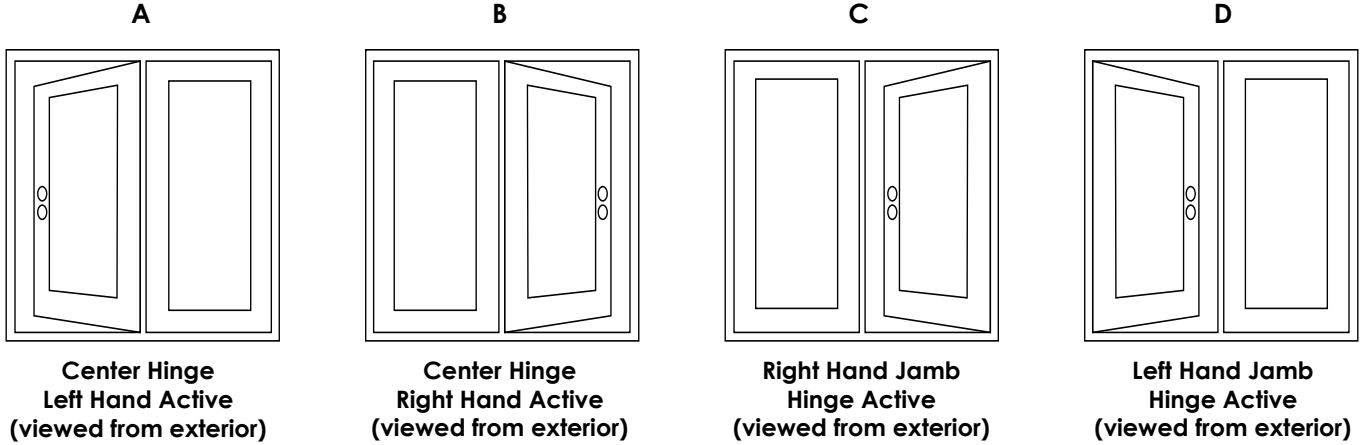

Patio Door Frame Kits with Crownline Nosing

| LIST PRICING | | | | | | | |
|------------------------|-----------|------------|------------|----------|--------------------|------------------|--|
| 4-9/16" Frame Kit | | | | Options | | | |
| Machined For: | Size | Qty 1-4 | Qty 5+ | J-Mould | 3-1/2" Flat Casing | 3-1/2" w/J-Mould | |
| 3 Hinges, Strike/DB | 6/0 x 6/8 | \$1,124.80 | \$1,022.40 | \$116.78 | \$234.52 | \$351.30 | |
| 3 Hinges, 3-Point Lock | 6/0 x 6/8 | \$1,184.80 | \$1,082.40 | \$116.78 | \$234.52 | \$351.30 | |
| 4 Hinges, Strike/DB | 6/0 x 8/0 | \$1,604.80 | \$1,502.40 | \$131.60 | \$262.34 | \$393.94 | |
| 4 Hinges, 3-Point Lock | 6/0 x 8/0 | \$1,664.80 | \$1,562.40 | \$131.60 | \$262.34 | \$393.94 | |

| 6-9/16" Frame Kit | | | | Options | | | |
|------------------------|-----------|------------|------------|----------|--------------------|------------------|--|
| Machined For: | Size | Qty 1-4 | Qty 5+ | J-Mould | 3-1/2" Flat Casing | 3-1/2" w/J-Mould | |
| 3 Hinges, Strike/DB | 6/0 x 6/8 | \$1,320.00 | \$1,200.00 | \$116.78 | \$234.52 | \$351.30 | |
| 3 Hinges, 3-Point Lock | 6/0 x 6/8 | \$1,380.00 | \$1,260.00 | \$116.78 | \$234.52 | \$351.30 | |
| 4 Hinges, Strike/DB | 6/0 x 8/0 | \$1,840.00 | \$1,720.00 | \$131.60 | \$262.34 | \$393.94 | |
| 4 Hinges, 3-Point Lock | 6/0 x 8/0 | \$1,900.00 | \$1,780.00 | \$131.60 | \$262.34 | \$393.94 | |

| | |
|--|--|
| Patio Door Frame Less than 6/0 width | Adder \$200.00 per frame |
| Weatherstrip installed | Adder \$25.00 per frame |
| FrontLine Sill with Boot (Mill Finish) | Adder \$380.00 per frame |
| Replacement Screen | Adder \$320.00 per frame |
| Patio Door Frame Larger than 6/0 Width | Please Call Customer Service for a Quote |

Note: For special jamb depth, you can purchase FLTA 77 variable depth expander with FLTA 60 Extender. FrontLine will not cut patio jamb depths down for special sizing.

Standard Colors:

White, Sandstone, Bronze, Almond, and Black.
(You can mix colors and handing to maximize quantity pricing)

***All Frame kits are cut and machined to customer specifications**

****SILL NOT INCLUDED UNLESS ORDERED AS EXTRA
15 Day Lead-Time Applies**

Included:

Head Jamb, Left and Right Vertical Jamb with Integrated Screen Track, Center Mull Post, Crownline Nosing, Aluminum Nailing Fin, Heavy-duty Extruded Screen with Fiberglass Mesh and TRU-LOC™ Installation Anchor (box of 8)



PRE-CLAD PATIO DOOR FRAME



FrontLine® Pre-Clad Patio Door Frame

Introducing our **Pre-Clad Patio Door Frame**, designed and developed to utilize the standard entry door platform for flexibility, performance and cost.

The hinged French patio door frame allows fabricators to fill that premiere opening on every project, connecting the home to the ever growing outdoor living space that homeowners desire today.

This system can be used for single-family dwellings, as well as light commercial projects such as multi-family and condos. Offering a limited lifetime warranty.

Rigid, folding aluminum nail fin

Lifetime warranty, no-rot primed composite frame

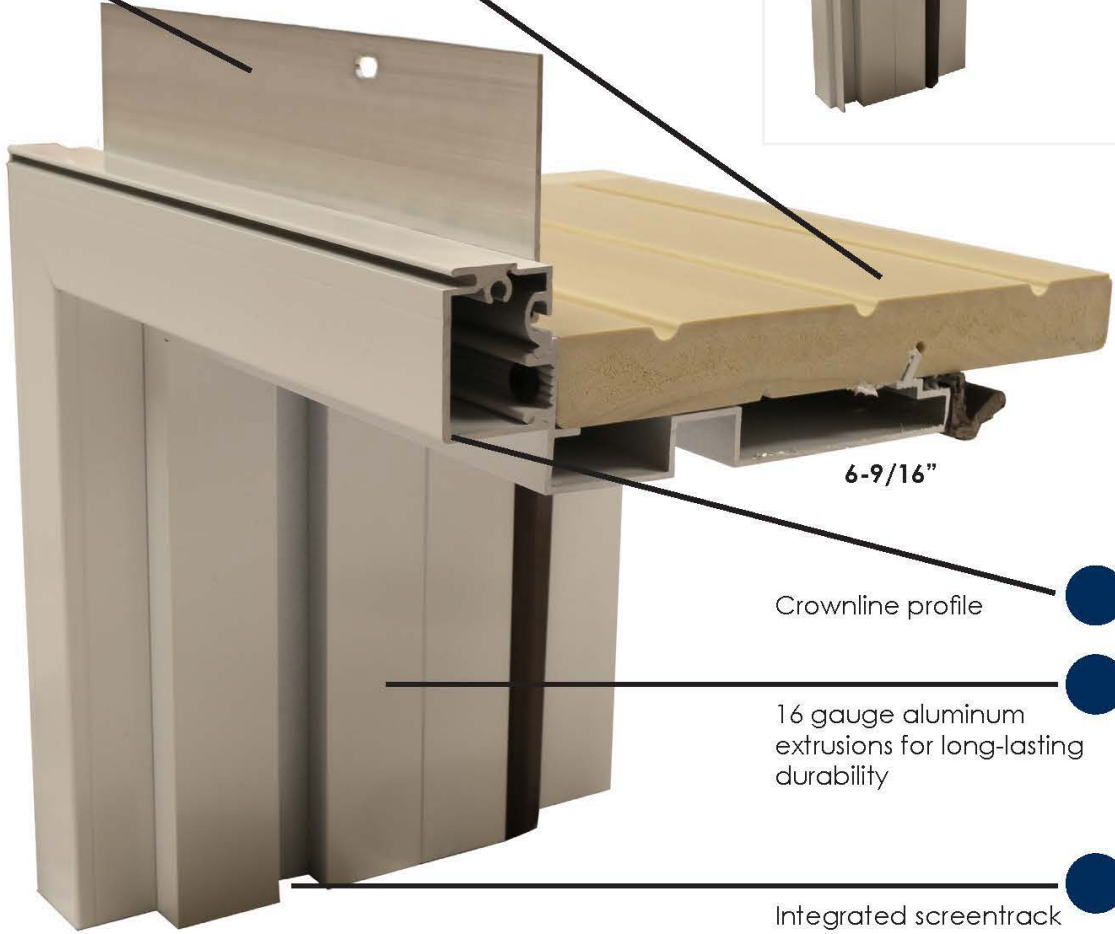

Crownline profile

16 gauge aluminum extrusions for long-lasting durability

Integrated screentrack
Heavy-duty screen
(not shown)

Patent No. US 7,454,865

Features

Hinged Patio Door Units

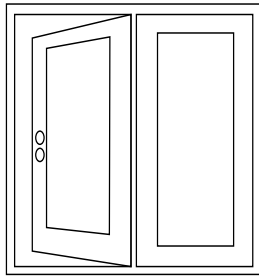

**Center Hinge
Left Hand Active
(viewed from exterior)**

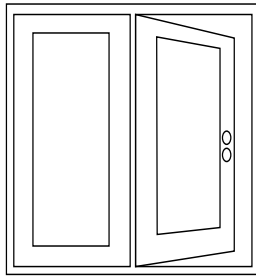

**Center Hinge
Right Hand Active
(viewed from exterior)**

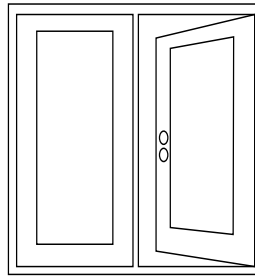

**Right Hand Jamb
Hinge Active
(viewed from exterior)**

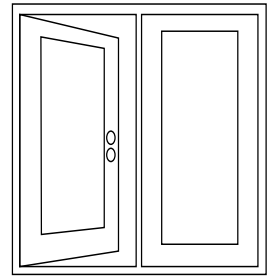

**Left Hand Jamb
Hinge Active
(viewed from exterior)**

Sold as a Kit - Ready to Assemble

- Available up to 6/0 width and 6/6 to 8/0 height.
- Pre-Clad 4-9/16" jamb with new integrated screen track on crownline nosing.
- Pre-clad 6-9/16" jamb with new integrated screen track and standard crownline nosing.
- 2-1/2" x 4-3/8" LVL-reinforced mull post with extruded aluminum cover for long-lasting durability and strength.
- Cut and machined to each fabricator's specifications.
- Heavy-duty extruded screen with fiberglass mesh.

- Rigid folding aluminum nail fin.
- Five colors: White, Sandstone, Black, Bronze and Almond
- TRU-LOC™ Installation Anchors (Box of 8)

Limited Lifetime Warranty

Add-on Options

- J-mould to achieve brickmould appearance.
- 3-1/2" flat casing
- 3-point lock
- Variable Depth Expander - For in between depths.

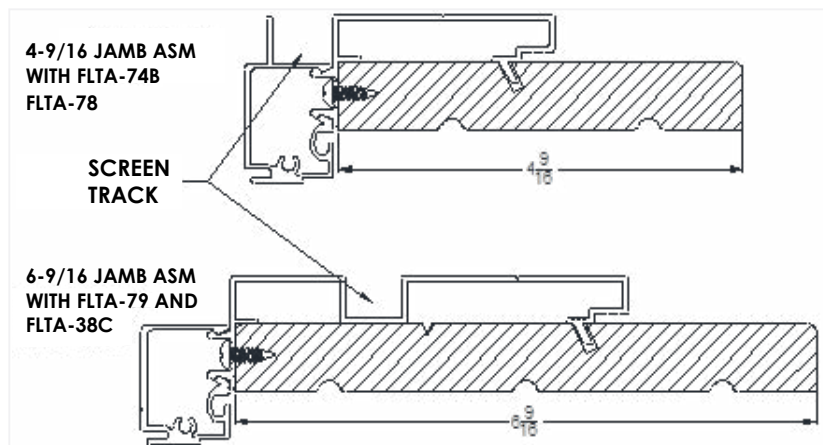

FRONTLINE® BLDG. PRODUCTS INC.

PATIO DOOR FRAME STOCKING DISTRIBUTOR PROGRAM



ADVANTAGES IN BECOMING A STOCKING FABRICATOR

- Discount on opening order
- Free Marketing Tools
- Discounted marketing tools
- Showcase/model home advantages

OPENING ORDER DETAILS

- Fabricator will receive an additional 5% discount with an opening order of 10 frames
- Will receive \$500.00 Quick Launch Co-op
- Will receive one free salesman samples
- Ability to purchase additional salesman sample at a reduced cost of \$75.00, that is 50% off

DISPLAY/SAMPLE PROGRAM

- Salesman samples - \$150.00 each
- Full Size Show Room Display
 - 4-9/16" - \$200.00 each
 - 6-9/16" - \$250.00 each
- Model/Parade Discounts - 20% off

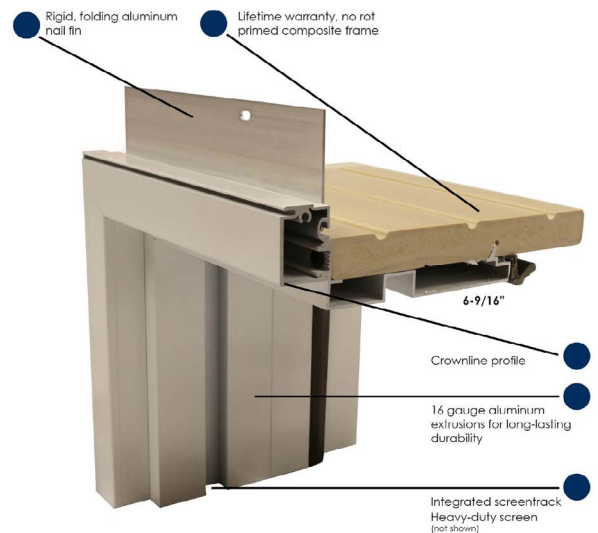

www.frontlinebldg.com | orders@frontlinebldg.com | 800-760-8941

TAB 6: PRICING COMPONENTS & LINEALS

(after page 26)

Cladding Components

- Each component type, size and color is packaged separately in a box. Quantities vary by extrusion.
- Components will be machined to individual customer frame specifications.
- When purchasing in this manner you must also purchase bulk frame cover screws (see Specialty Pricing Section)
- Preferred method of purchasing for commonly used colors and configurations.
- Popular option for high volume prehangs and established cladding operations.
- Each box is custom labeled with as much or as little information as desired. Labels are applied both on face and end of box.
- 14 Standard Colors

Clad Components and Lineals

List prices. Subject to discount.

| Parts | Quantity 1-19 Pieces Each | | Quantity 20+ | | Lineal Lengths Each | |
|-------|---------------------------|--|---------------|--|---------------------|--|
| | Standard Size | | Standard Size | | Full Length | |

Folding Aluminum Nail Fin (FLTA-56)

| | | | | | |
|----|---------|----|---------|-----|--|
| 7' | \$17.20 | 7' | \$15.44 | N/A | |
|----|---------|----|---------|-----|--|

Vinyl Nail Fin (FLTA-2294)

| | | | | | |
|----|---------|----|---------|-----|--|
| 7' | \$11.08 | 7' | \$11.08 | N/A | |
| 8' | \$12.70 | 8' | \$12.70 | | |

Brickmould Casing (FLTA-39)



| Headers | | Headers | | | |
|-----------|---------|-----------|---------|--------|----------|
| 2/8 - 3/0 | \$25.78 | 2/8 - 3/0 | \$23.12 | 14' 4" | \$115.34 |
| 5-0 | \$51.46 | 5-0 | \$46.28 | 16' 8" | \$134.00 |
| 6-0 | \$60.08 | 6-0 | \$54.00 | 18' 6" | \$145.52 |
| 7-0 | \$68.64 | 7-0 | \$61.68 | | |
| 8-0 | \$77.28 | 8-0 | \$69.40 | | |
| 10-0 | \$94.50 | 10-0 | \$84.84 | | |
| Verticals | | Verticals | | | |
| 6-8 | \$60.08 | 6-8 | \$54.00 | | |
| 7-0 | \$68.64 | 7-0 | \$61.68 | | |
| 8-0 | \$77.28 | 8-0 | \$69.40 | | |
| 10-0 | \$94.44 | 10-0 | \$84.84 | | |

Crownline Casing (FLTA-38)



| Headers | | Headers | | | |
|-----------|---------|-----------|---------|--------|----------|
| 2/8 - 3/0 | \$23.48 | 2/8 - 3/0 | \$21.08 | 14' 4" | \$105.40 |
| 5-0 | \$46.92 | 5-0 | \$42.16 | 16' 8" | \$120.00 |
| 6-0 | \$54.74 | 6-0 | \$49.20 | 18' 6" | \$133.52 |
| 7-0 | \$62.62 | 7-0 | \$56.24 | | |
| 8-0 | \$70.42 | 8-0 | \$63.28 | | |
| 10-0 | \$85.94 | 10-0 | \$77.32 | | |
| Verticals | | Verticals | | | |
| 6-8 | \$54.74 | 6-8 | \$49.20 | | |
| 7-0 | \$62.62 | 7-0 | \$56.24 | | |
| 8-0 | \$70.42 | 8-0 | \$63.28 | | |
| 10-0 | \$86.04 | 10-0 | \$77.32 | | |

Slimline Casing (FLTA-34)



| Headers | | Headers | | | |
|-----------|---------|-----------|---------|--------|---------|
| 2/8 - 3/0 | \$20.28 | 2/8 - 3/0 | \$18.20 | 14' 8" | \$91.16 |
| 5-0 | \$40.46 | 5-0 | \$36.38 | | |
| 6-0 | \$47.28 | 6-0 | \$42.46 | | |
| 7-0 | \$54.00 | 7-0 | \$48.52 | | |
| 8-0 | \$60.74 | 8-0 | \$54.58 | | |
| 10-0 | \$74.56 | 10-0 | \$66.58 | | |
| Verticals | | Verticals | | | |
| 6-8 | \$47.28 | 6-8 | \$42.46 | | |
| 7-0 | \$54.00 | 7-0 | \$48.52 | | |
| 8-0 | \$60.74 | 8-0 | \$54.58 | | |
| 10-0 | \$74.22 | 10-0 | \$66.68 | | |

Note: Colors available on page 36

Clad Components and Lineals

List prices. Subject to discount.

| Parts | Quantity 1-19 Pieces Each Standard Size | Quantity 20+ Standard Size | Lineal Lengths Each Full Length | |
|-------|--|-------------------------------|------------------------------------|--|
|-------|--|-------------------------------|------------------------------------|--|

4-9/16" Jamb Cover (FLTA-41)



| Headers | | Headers | | Lineal Lengths Each | |
|-----------|---------|-----------|---------|---------------------|----------|
| 2/8 - 3/0 | \$22.72 | 2/8 - 3/0 | \$20.40 | 14' 4" | \$101.96 |
| 5-0 | \$45.36 | 5-0 | \$40.78 | | |
| 6-0 | \$53.00 | 6-0 | \$47.58 | | |
| 7-0 | \$60.54 | 7-0 | \$54.38 | | |
| 8-0 | \$68.12 | 8-0 | \$61.18 | | |
| 10-0 | \$83.00 | 10-0 | \$74.64 | | |
| Verticals | | Verticals | | | |
| 6-8 | \$53.00 | 6-8 | \$47.58 | | |
| 7-0 | \$60.54 | 7-0 | \$54.38 | | |
| 8-0 | \$68.12 | 8-0 | \$61.18 | | |
| 10-0 | \$83.26 | 10-0 | \$74.74 | | |

6-9/16" Jamb Cover (FLTA-40)



| Headers | | Headers | | Lineal Lengths Each | |
|-----------|----------|-----------|----------|---------------------|----------|
| 2/8 - 3/0 | \$33.50 | 2/8 - 3/0 | \$30.06 | 14' 4" | \$150.34 |
| 5-0 | \$67.02 | 5-0 | \$60.20 | 16' 8" | \$171.56 |
| 6-0 | \$78.14 | 6-0 | \$70.18 | 18' 6" | \$194.42 |
| 7-0 | \$89.30 | 7-0 | \$80.24 | | |
| 8-0 | \$100.54 | 8-0 | \$90.32 | | |
| 10-0 | \$122.94 | 10-0 | \$110.08 | | |
| Verticals | | Verticals | | | |
| 6-8 | \$78.14 | 6-8 | \$70.20 | | |
| 7-0 | \$89.30 | 7-0 | \$80.24 | | |
| 8-0 | \$100.54 | 8-0 | \$90.32 | | |
| 10-0 | \$122.78 | 10-0 | \$110.30 | | |

6-13/16" Jamb Cover (FLTA-45)



| Headers | | Headers | | Lineal Lengths Each | |
|-----------|----------|-----------|----------|---------------------|----------|
| 2/8 - 3/0 | \$34.50 | 2/8 - 3/0 | \$31.24 | 14' 4" | \$152.26 |
| 5-0 | \$68.84 | 5-0 | \$61.86 | | |
| 6-0 | \$80.32 | 6-0 | \$72.14 | | |
| 7-0 | \$91.92 | 7-0 | \$82.40 | | |
| 8-0 | \$103.36 | 8-0 | \$92.82 | | |
| 10-0 | \$126.64 | 10-0 | \$113.12 | | |
| Verticals | | Verticals | | | |
| 6-8 | \$81.26 | 6-8 | \$72.24 | | |
| 7-0 | \$91.92 | 7-0 | \$82.40 | | |
| 8-0 | \$103.36 | 8-0 | \$92.82 | | |
| 10-0 | \$126.20 | 10-0 | \$113.44 | | |

Note: Colors available on page 36



Clad Components and Lineals

List prices. Subject to discount.

| Parts | Quantity 1-19 Pieces Each Standard Size | Quantity 20+ Standard Size | Lineal Lengths Each Full Length | |
|-------|--|-------------------------------|------------------------------------|--|
|-------|--|-------------------------------|------------------------------------|--|

*8-9/16" Jamb Cover (FLTA-81)



| Headers | | Headers | | 18'6" | \$419.36 |
|-----------|----------|-----------|----------|-------|----------|
| 2/8 - 3/0 | \$79.34 | 2/8 - 3/0 | \$73.00 | | |
| 5-0 | \$113.34 | 5-0 | \$104.28 | | |
| 6-0 | \$136.02 | 6-0 | \$125.14 | | |
| 7-0 | \$158.68 | 7-0 | \$146.00 | | |
| 8-0 | \$181.36 | 8-0 | \$166.84 | | |
| 10-0 | \$226.70 | 10-0 | \$208.56 | | |
| Verticals | | Verticals | | | |
| 6-8 | \$151.14 | 6-8 | \$139.04 | | |
| 7-0 | \$158.68 | 7-0 | \$146.00 | | |
| 8-0 | \$181.36 | 8-0 | \$166.84 | | |
| 10-0 | \$226.70 | 10-0 | \$208.56 | | |

4-9/16" Jamb Cover (FLTA-293) With integrated nail fin



| Headers | | Headers | | 14'8" | \$130.32 |
|-----------|----------|-----------|---------|-------|----------|
| 2/8 - 3/0 | \$29.08 | 2/8 - 3/0 | \$26.12 | | |
| 5-0 | \$58.14 | 5-0 | \$52.24 | | |
| 6-0 | \$67.82 | 6-0 | \$60.96 | | |
| 7-0 | \$77.50 | 7-0 | \$69.66 | | |
| 8-0 | \$87.24 | 8-0 | \$78.40 | | |
| 10-0 | \$106.42 | 10-0 | \$95.58 | | |
| Verticals | | Verticals | | | |
| 6-8 | \$67.82 | 6-8 | \$60.96 | | |
| 7-0 | \$77.50 | 7-0 | \$69.99 | | |
| 8-0 | \$87.24 | 8-0 | \$78.40 | | |
| 10-0 | \$106.62 | 10-0 | \$95.76 | | |

6-9/16" Jamb Cover (FLTA-273) With integrated nail fin



| Headers | | Headers | | 14'8" | \$192.44 |
|-----------|----------|-----------|----------|-------|----------|
| 2/8 - 3/0 | \$42.88 | 2/8 - 3/0 | \$38.48 | | |
| 5-0 | \$85.80 | 5-0 | \$77.04 | | |
| 6-0 | \$100.02 | 6-0 | \$89.82 | | |
| 7-0 | \$114.30 | 7-0 | \$102.70 | | |
| 8-0 | \$128.68 | 8-0 | \$115.60 | | |
| 10-0 | \$157.36 | 10-0 | \$140.88 | | |
| Verticals | | Verticals | | | |
| 6-8 | \$100.02 | 6-8 | \$89.82 | | |
| 7-0 | \$114.30 | 7-0 | \$102.70 | | |
| 8-0 | \$128.68 | 8-0 | \$115.60 | | |
| 10-0 | \$157.16 | 10-0 | \$141.18 | | |

Mull Cap (FLTA-36)



| Mull Caps | | Mull Caps | | 14'4" | \$75.16 |
|-----------|---------|-----------|---------|-------|---------|
| 3/0 | \$20.94 | 3/0 | \$18.79 | | |
| 6/8 - 7/0 | \$41.88 | 6/8 - 7/0 | \$37.58 | | |
| 8/0 | \$47.86 | 8/0 | \$42.94 | | |

Note: Colors available on page 36

*Limited Colors: White, Black, Sandstone, Bronze, Terratone, Bahama Brown, Green, & Almond



Clad Components and Lineals

List prices. Subject to discount.

| Parts | Quantity 1-19 Pieces Each | | Quantity 20+ | | Lineal Lengths Each | |
|-------|---------------------------|--|---------------|--|---------------------|--|
| | Standard Size | | Standard Size | | Full Length | |

Mullion Cap (FLTA-44) For joining two Crownline together



| | | | | | |
|-----|---------|-----|---------|-----|---------|
| 6/8 | \$20.64 | 6/8 | \$18.74 | 14' | \$37.10 |
| 7/0 | \$20.64 | 7/0 | \$18.74 | | |

Spread Mull End Cap (FLTA-52)

| | | | | | |
|-----------|---------|-----------|---------|--------|---------|
| 6/8 - 7/0 | \$38.82 | 6/8 - 7/0 | \$34.88 | 14' 4" | \$71.30 |
|-----------|---------|-----------|---------|--------|---------|

Spread Mull Universal Plate (FLTA-53)



| | | | | | |
|-----------|---------|-----------|---------|--------|----------|
| 6/8 - 7/0 | \$69.96 | 6/8 - 7/0 | \$62.78 | 14' 4" | \$128.44 |
|-----------|---------|-----------|---------|--------|----------|

Jamb Expander 2-1/2" (FLTA-75) 3/16" Return



| | | | | | |
|-----|---------|-----|---------|--------|----------|
| 8/0 | \$61.74 | 8/0 | \$55.12 | 16' 4" | \$112.52 |
|-----|---------|-----|---------|--------|----------|



Application Tape (for part FLTA-75)
1-1/2" x 180' Roll (32 Rolls / CS)

List \$26.30/Roll

Transom Glazing Leg (FLTA-76)

To be used for cladding rectangular transoms only. (See page 46 for colors)



| | | | | | |
|-----|---------|-----|---------|--------|---------|
| 9/0 | \$47.04 | 9/0 | \$45.32 | 18' 0" | \$84.72 |
|-----|---------|-----|---------|--------|---------|

Crownline Pro-Tex™ Protective Cover (FLTA-619)

Sold in boxes of 100 each.

| | | | | | |
|-----|--|-----|--------|--|--|
| N/A | | 7/0 | \$3.93 | | |
|-----|--|-----|--------|--|--|

Brickmould Pro-Tex™ Protective Cover (FLTA-3273)

Sold in boxes of 100 each

| | | | | | |
|-----|--|-----|--------|--|--|
| N/A | | 7/0 | \$4.09 | | |
|-----|--|-----|--------|--|--|

Variable Depth Expander (FLTA-77 for pre-clad system)



| | | | | | |
|-----|---------|-----|---------|--------|---------|
| 7/0 | \$40.46 | 7/0 | \$34.44 | 14' 0" | \$66.88 |
|-----|---------|-----|---------|--------|---------|

Note: Colors available on page 36



Clad Components and Lineals

List prices. Subject to discount.

| Parts | Quantity 1-19 Pieces Each | | Quantity 20+ | | Lineal Lengths Each | |
|-------|---------------------------|--|---------------|--|---------------------|--|
| | Standard Size | | Standard Size | | Full Length | |

2" Frame Extension (FLTA-60) Snaps onto jamb cover locking points



| Quantity | Price | Quantity | Price | Length | Price |
|----------|----------|----------|----------|--------|----------|
| 3/0 | \$39.41 | 3/0 | \$35.47 | 14' 4" | \$188.28 |
| 5/0 | \$65.68 | 5/0 | \$59.11 | 18' 6" | \$243.01 |
| 6/0 | \$78.81 | 6/0 | \$70.93 | | |
| 7/0 | \$91.95 | 7/0 | \$82.75 | | |
| 8/0 | \$105.08 | 8/0 | \$94.58 | | |
| 10/0 | \$131.36 | 10/0 | \$118.22 | | |

*5/8" Frame Expander (FLTA-61)



| Quantity | Price | Quantity | Price | Length | Price |
|----------|---------|----------|---------|--------|----------|
| 3/0 | \$17.07 | 3/0 | \$15.36 | 18' 6" | \$105.27 |
| 5/0 | \$28.45 | 5/0 | \$25.61 | | |
| 6/0 | \$34.14 | 6/0 | \$30.73 | | |
| 7/0 | \$39.83 | 7/0 | \$35.85 | | |
| 8/0 | \$45.52 | 8/0 | \$40.97 | | |
| 10/0 | \$56.90 | 10/0 | \$51.21 | | |

J-Mould add on (FLTA-48)



| Headers | | Headers | | Length | Price |
|-----------|---------|-----------|---------|--------|-------|
| 2/8 - 3/0 | \$21.32 | 2/8 - 3/0 | \$16.12 | | |
| 5/0 | \$32.42 | 5/0 | \$29.08 | | |
| 6/0 | \$37.98 | 6/0 | \$34.08 | | |
| 7/0 | \$43.54 | 7/0 | \$39.06 | | |
| 8/0 | \$49.10 | 8/0 | \$44.04 | | |
| 10/0 | \$60.24 | 10/0 | \$54.02 | | |
| Verticals | | Verticals | | | |
| 6/8 | \$39.40 | 6/8 | \$35.34 | | |
| 7/0 | \$41.24 | 7/0 | \$36.98 | | |
| 8/0 | \$46.80 | 8/0 | \$41.96 | | |
| 10/0 | \$57.92 | 10/0 | \$51.96 | | |

3-1/2" add on Casing (FLTA-47)



| Headers | | Headers | | Length | Price |
|-----------|----------|-----------|----------|--------|-------|
| 2/8 - 3/0 | \$45.04 | 2/8 - 3/0 | \$40.40 | | |
| 5/0 | \$65.96 | 5/0 | \$59.16 | | |
| 6/0 | \$46.70 | 6/0 | \$68.52 | | |
| 7/0 | \$86.86 | 7/0 | \$77.90 | | |
| 8/0 | \$97.37 | 8/0 | \$87.32 | | |
| 10/0 | \$128.10 | 10/0 | \$114.88 | | |
| Verticals | | Verticals | | | |
| 6/8 | \$79.06 | 6/8 | \$70.90 | | |
| 7/0 | \$82.54 | 7/0 | \$74.00 | | |
| 8/0 | \$92.96 | 8/0 | \$83.38 | | |
| 10/0 | \$118.28 | 10/0 | \$106.08 | | |

Note: Colors available on page 36

*Limited Colors: White, Black, Sandstone, & Bronze



One Piece Mull Cover List Pricing

List prices. Subject to discount.

1-Piece Mull Cover for a 2-1/2" Mull Post

| Parts | Quantity 1-19 Pieces Each Standard Size | Quantity 20+ Standard Size | Lineal Lengths Each Full Length |
|-------|--|-------------------------------|------------------------------------|
|-------|--|-------------------------------|------------------------------------|

6-9/16" (FLTA-65)

| | | | | | |
|-----|----------|-----|----------|--------|----------|
| 6/8 | \$172.16 | 6/8 | \$154.40 | 14' 4" | \$308.02 |
| 7/0 | \$180.78 | 7/0 | \$162.12 | | |
| 8/0 | \$206.58 | 8/0 | \$185.28 | | |

4-9/16" (FLTA-68)



| | | | | | |
|-----|----------|-----|----------|--------|----------|
| 6/8 | \$116.48 | 6/8 | \$104.00 | 14' 4" | \$207.50 |
| 7/0 | \$122.30 | 7/0 | \$109.00 | | |
| 8/0 | \$139.78 | 8/0 | \$124.80 | | |

1-Piece Mull Cover for a 2" Mull Post

| Parts | Quantity 1-19 Pieces Each Standard Size | Quantity 20+ Standard Size | Lineal Lengths Each Full Length |
|-------|--|-------------------------------|------------------------------------|
|-------|--|-------------------------------|------------------------------------|

6-9/16" (FLTA-64)

| | | | | | |
|-----|----------|-----|----------|--------|----------|
| 6/8 | \$166.02 | 6/8 | \$148.24 | 14' 4" | \$295.80 |
| 7/0 | \$174.36 | 7/0 | \$155.68 | | |
| 8/0 | \$199.53 | 8/0 | \$177.92 | | |

4-9/16" (FLTA-71)



| | | | | | |
|-----|----------|-----|----------|--------|----------|
| 6/8 | \$111.10 | 6/8 | \$99.20 | 14' 4" | \$198.44 |
| 7/0 | \$116.99 | 7/0 | \$104.44 | | |
| 8/0 | \$133.68 | 8/0 | \$119.36 | | |

Note: Colors available on page 36



FrontLine® Profiles

The FrontLine® profiles are all 6" pieces of all cladding components available.
Order by assigned part number for profiles.



Brickmould Casing
FLTA-39



Crownline Casing
FLTA-38



Slimline Casing
FLTA-34



3-1/2" Add on Flat Casing
FLTA-47
Attaches to Crownline



J-Mould
FLTA-48
Attaches to Crownline and
3-1/2" Flat Casing



4-9/16" Jamb Cover
FLTA-41



6-9/16" Jamb Cover
FLTA-40



6-13/16" Jamb Cover
FLTA-45



**4-9/16" Jamb Cover with
Rigid Nail Fin**
FLTA-293



**6-9/16" Jamb Cover with
Rigid Nail Fin**
FLTA-273



Mullion Cap
FLTA-36



Mullion Cap
FLTA-44



2" 1-Piece Mull Cover
FLTA-64: 6-9/16"
FLTA-71: 4-9/16"



2-1/2" 1-Piece Mull Cover
FLTA-65: 6-9/16"
FLTA-68: 4-9/16"



Transom Glazing Leg
FLTA-76
To be used for cladding
rectangular transoms



2-1/2" Jamb Expander
FLTA-75



2" Frame Extension
FLTA-60



Variable Depth Expander
FLTA-77



6-9/16" Pre-Clad Jamb Cover
FLTA-73



4-9/16" Pre-Clad Jamb Cover
FLTA-74



Outswing Clad
FLTA-30



Spread Mull Clad
(Two end caps with a universal plate)
FLTA-52: End Caps
FLTA-53: Universal Plate



Aluminum Nail Fin
FLTA-56



Vinyl Nail Fin
FLTA-2294



Expander Application Tape
for applying FLTA-75

Lineal Color Chart

| Profile | Description | Size | White | Sandstone | Bronze | Bahama Brown | Green | Terratone | Almond | Eggshell | Wineberry | Beige | Black | Arctic Silver | Primed | Iron Ore |
|---------|-------------------------------------|--------|-------|-----------|--------|--------------|-------|-----------|--------|----------|-----------|-------|-------|---------------|--------|----------|
| FLTA34 | Slimline | 14'8 | X | X | X | X | X | X | X | X | X | X | X | | | |
| FLTA38 | Crownline | 14'4 | X | X | X | X | X | X | X | X | | | X | | | |
| FLTA38 | Crownline | 16'8 | X | X | | | | | | | | | | | | |
| FLTA38 | Crownline | 18'6 | X | X | X | X | X | X | X | X | X | X | X | X | X | X |
| FLTA39 | Brickmould | 14'4 | X | X | X | X | X | X | X | | | | X | | | |
| FLTA39 | Brickmould | 16'8 | X | X | | | | | | | | | | | | |
| FLTA39 | Brickmould | 18'6 | X | X | X | X | X | X | X | X | X | X | X | X | X | X |
| FLTA40 | 6-9/16" Jamb | 14'4 | X | X | X | X | X | X | X | X | | | X | | | |
| FLTA40 | 6-9/16" Jamb | 16'8 | X | X | | | | | | | | | | | | |
| FLTA40 | 6-9/16" Jamb | 18'6 | X | X | X | X | X | X | X | X | X | X | X | X | X | X |
| FLTA41 | 4-9/16" Jamb | 14'4 | X | X | X | X | X | X | X | X | X | X | X | X | X | X |
| FLTA45 | 6-13/16" Jamb | 14'4 | X | X | X | X | X | X | X | X | X | X | X | X | | |
| FLTA81 | 8-9/16 Jamb | 18'6 | X | X | X | X | X | X | X | | | | X | | | |
| FLTA273 | 6-9/16" Jamb w/ rigid nail fin | 14'8 | X | X | X | X | X | X | X | X | X | X | X | | | |
| FLTA293 | 4-9/16" Jamb w/ rigid nail fin | 14'8 | X | X | X | X | X | X | X | X | X | X | X | | | |
| FLTA64 | 2" One piece Mull cover 6-9/16" | 14'4 | X | X | X | X | X | X | X | X | X | X | X | | X | |
| FLTA65 | 2.5" One piece Mull cover 6-9/16" | 14'4 | X | X | X | X | X | X | X | X | X | X | X | X | X | |
| FLTA68 | 2.5" One piece Mull cover 4-9/16" | 14'4 | X | X | X | X | X | X | X | X | X | X | X | | X | |
| FLTA71 | 2" One piece Mull cover 4-9/16" | 14'4 | X | X | X | X | X | X | X | X | X | X | | | | |
| FLTA36 | Mull Cap | 14'4 | X | X | X | X | X | X | X | X | X | X | X | X | X | X |
| FLTA44 | Mullion Cap | 14'0 | X | X | X | X | X | X | X | X | X | X | X | | X | |
| FLTA46 | 5-1/2" Pro-Series Garage Door Frame | 18'11" | X | X | X | X | X | X | X | X | X | X | X | | | |
| FLTA47 | 3-1/2" Casing | 19'2 | X | X | X | X | X | X | X | X | X | X | X | | X | |
| FLTA48 | J-Mould | 19'5 | X | X | X | X | X | X | X | X | X | X | X | | X | |
| FLTA51 | 7-1/2" Pro-Series Garage Door Frame | 18'11" | X | X | X | X | X | X | X | X | X | X | X | | | |
| FLTA52 | Spread Mull End Cap | 14'4 | X | X | X | X | X | X | X | X | X | X | X | | | |
| FLTA53 | Spread Mull Universal Plate | 14'4 | X | X | X | X | X | X | X | X | X | X | X | | | |
| FLTA54 | 5-1/2" Arch Top Garage Door Frame | 20'0 | X | X | X | X | X | X | X | X | X | X | X | | | |
| FLTA55 | 5-1/2" Arch Top Garage Door Frame | 20'0 | X | X | X | X | X | X | X | X | X | X | X | | | |
| FLTA60 | 2" Frame Extender | 14'4 | X | X | | | | | | | | | | | | |
| FLTA60 | 2" Frame Extender | 18'6 | X | X | X | X | X | X | X | X | X | X | X | | | |
| FLTA61 | 5/8" Frame Extender | 18'6 | X | X | X | | | | | | | | X | | | |
| FLTA73 | 6-9/16" Pre-Clad Aluminum | 14' | X | X | X | | | X | | | | | X | | | |
| FLTA74 | 6-9/16" Pre-Clad Aluminum | 14" | X | X | X | | | X | X | | | | X | | | |
| FLTA75 | 2-1/2" Jamb Expander | 16'4 | X | X | X | X | X | X | X | X | X | X | X | X | X | |
| FLTA76 | Transom Glazing Leg | 18'0 | X | X | X | | | X | | | | | X | | X | |
| FLTA77 | Pre-Clad Variable Depth Expander | 14' | X | X | X | | | X | | | | | X | | | |
| FLTA30 | Outswing | 14'6 | X | X | X | X | X | X | X | X | X | X | X | X | | |



TAB 7: OUTSWING CLAD
(after page 35)

Clad Outswing Entry Door System

Offered exclusively by Frontline® Bldg. Products Inc. A perfect complement for your maintenance-free Entry Door. Attractive .062" extruded aluminum finished in White, Bronze, Sandstone, Terratone, Bahama Brown, Green, Almond, Eggshell, Wineberry, Beige, Arctic Silver, or Black.

Sets:

| | |
|---|------------|
| Single Door 2/8 - 3/0 / 6-8. | \$167.04 |
| Double Door up to 6-0 x 6-8. | \$201.60 |
| Door Units over 6-8 in height | \$10.08/LF |
| Lineal Full Length (14' 6") | \$146.06 |
| 3/0 Header. | \$29.53 |
| 6/0 Header. | \$68.88 |
| 6/8 Vertical | \$68.88 |
| 7/0 Vertical | \$70.56 |
| 8/0 Vertical | \$80.64 |

| Optional: | Single | Double |
|-------------------------------|---------|---------|
| Rout for 3 hinges | \$35.28 | \$70.56 |
| Rout for 4th hinge add \$5.88 | | |
| Rout for latch | \$12.96 | N/A |
| Rout for deadbolt | \$12.96 | N/A |

Addition of sidelites available. (Call for quotation)

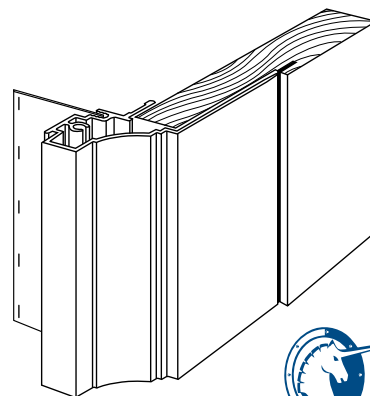
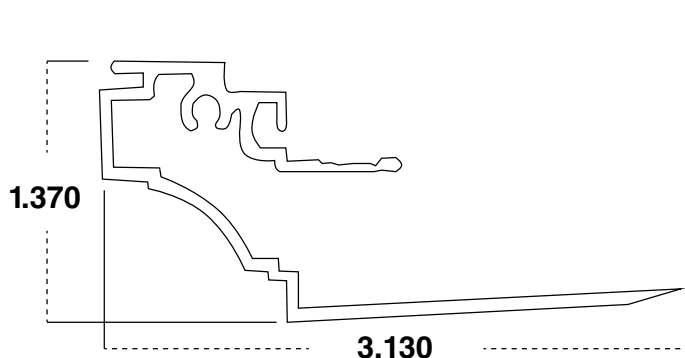
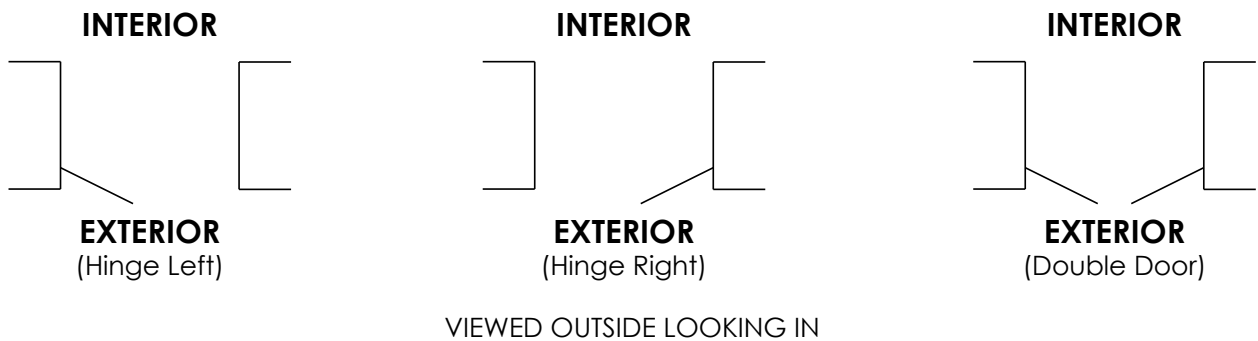

Clad Outswing Order Form

(All outswing orders require spec sheets with all dimensions)

Customer _____ Date _____

Address _____

PO Number _____

HEADER

2/8 3/0 5/4 6/0 Other: _____

HINGING (as viewed from outside)

Left Right

LATCH ROUTING

Yes No

DEADBOLT ROUTING

Yes No

COLOR

White Bronze Sandstone Terratone Bahama Brown Green
 Almond Eggshell Wineberry Beige Arctic Silver Black

DOOR BRAND

SIDELITES

QUANTITY: 1 2

SIZE: 12" 14"

FrontLine® Bldg. Products Inc.
1100 S. Huron Road
Green Bay, WI 54311
Phone: 920-393-1340
Fax: 920-227-9590



TAB 8: FRONTLINE COMPOSITE FRAME

(after page 37)

Primed Composite

| PRIMED COMPOSITE PRICING | | | | | | |
|--------------------------|-------------|---------------|-------------|---------------|----------------------|------------------|
| NON PREPPED JAMB | | | | | | |
| 4-9/16" Jamb | Full Pallet | | Half Pallet | | Carton Pack (20 Pcs) | Less Than Carton |
| 2/8 or 3/0 | \$28.30 | (368 per PLT) | \$29.70 | (184 per PLT) | \$32.54 | \$41.02 |
| 6/8 | \$61.98 | (368 per PLT) | \$65.08 | (184 per PLT) | \$71.28 | \$89.88 |
| 8/0 | \$74.76 | (368 per PLT) | \$78.50 | (184 per PLT) | \$85.98 | \$108.42 |
| 12' lineal | N/A | N/A | N/A | N/A | \$129.60 | \$163.40 |
| 5-1/4" Jamb** | Full Pallet | | Half Pallet | | Carton Pack (20 Pcs) | Less Than Carton |
| 2/8 or 3/0 | \$39.96 | (240 per PLT) | \$41.96 | (120 per PLT) | \$45.96 | \$57.94 |
| 6/8 | \$92.12 | (240 per PLT) | \$96.72 | (120 per PLT) | \$105.92 | \$133.56 |
| 8/0 | \$109.88 | (240 per PLT) | \$115.38 | (120 per PLT) | \$126.36 | \$159.34 |
| 6-9/16" Jamb | Full Pallet | | Half Pallet | | Carton Pack (20 Pcs) | Less Than Carton |
| 2/8 or 3/0 | \$45.56 | (180 per PLT) | \$47.87 | (90 Per PLT) | \$52.38 | \$66.06 |
| 6/8 | \$99.66 | (180 per PLT) | \$104.64 | (90 Per PLT) | \$114.60 | \$144.50 |
| 8/0 | \$119.04 | (180 per PLT) | \$124.98 | (90 Per PLT) | \$136.88 | \$172.60 |
| 12' lineal | N/A | N/A | N/A | N/A | \$211.86 | \$266.62 |
| 7-1/4" Jamb** | Full Pallet | | Half Pallet | | Carton Pack (20 Pcs) | Less Than Carton |
| 2/8 or 3/0 | \$66.68 | (180 per PLT) | \$70.00 | (90 Per PLT) | \$76.68 | \$96.68 |
| 6/8 | \$154.36 | (180 per PLT) | \$162.08 | (90 Per PLT) | \$177.52 | \$223.82 |
| 8/0 | \$184.16 | (180 per PLT) | \$193.38 | (90 Per PLT) | \$211.78 | \$267.04 |

Pallet quantities are based on the same prep. i.e. 180 RT hand strike preps, 180 RT hand hinge preps.

****Some sizes may not be in stock. Please call Customer Service to verify.**

| MACHINING and WEATHERSTRIP ADDERS | | | | |
|-----------------------------------|---|---|--------------|---|
| | Prepping Charge: Sill Cut, Hinge and Latch | Installation Pilot Holes: Per Jamb or Head | Weatherstrip | Pilot Holes for Head and Sill Assembly |
| 3/0 Jamb Head (each) | | | \$6.25 | |
| 6/8 Jamb (each) | \$4.59 | \$4.59 | \$12.20 | \$4.59 |
| 8/0 Jamb (each) | \$4.59 | \$4.59 | \$15.00 | \$4.59 |

| KERF ADDER for Jamb (*Spline) | |
|-------------------------------|---------|
| 3/0 Jamb Head (each) | \$5.00 |
| 6/8 Jamb (each) | \$8.00 |
| 8/0 Jamb (each) | \$10.00 |

| KERF ADDER for BRICKMOULD (*Spline) | |
|-------------------------------------|---------|
| 3/0 BM Head (each) | \$5.00 |
| 6/8 BM (each) | \$8.00 |
| 8/0 BM (each) | \$10.00 |

* Note: spline not provided by FrontLine

| 180 PRIMED BRICKMOULD | | | | | | |
|-----------------------|-------------|---------------|-------------|---------------|----------------------|------------------|
| | Full Pallet | | Half Pallet | | Carton Pack (20 Pcs) | Less Than Carton |
| 3/0 | \$15.34 | (640 Per PLT) | \$15.98 | (320 Per PLT) | \$17.26 | \$21.08 |
| 6/8 | \$28.74 | (640 Per PLT) | \$30.06 | (320 Per PLT) | \$32.68 | \$40.52 |
| 8/0 | \$35.06 | (640 Per PLT) | \$36.68 | (320 Per PLT) | \$39.94 | \$49.68 |
| 17' Lineal | \$69.12 | (640 Per PLT) | \$72.46 | (320 Per PLT) | \$79.10 | \$99.06 |

Pallet Quantities are based on all right verticals or all left verticals.



Primed Composite

| MULL POST - LVL REINFORCEMENT | | | | |
|-------------------------------|-----------------------------|-----------------------------|-----------------------------|-------------------------|
| 2" X 4-3/8" | Full Pallet (90 Pcs) | Half Pallet (45 Pcs) | Carton Pack (20 Pcs) | Less Than Carton |
| 6/8 | \$249.32 | \$261.78 | \$286.72 | \$361.52 |
| 8/0 | \$267.56 | \$280.94 | \$307.70 | \$387.96 |
| 2-1/2" X 4-3/8" | Full Pallet (90 Pcs) | Half Pallet (45 Pcs) | Carton Pack (20 Pcs) | Less Than Carton |
| 6/8 | \$249.32 | \$261.78 | \$286.72 | \$361.52 |
| 8/0 | \$267.56 | \$280.94 | \$307.70 | \$387.96 |
| 2-1/2" X 4-9/16" | Full Pallet (90 Pcs) | Half Pallet (45 Pcs) | Carton Pack (20 Pcs) | Less Than Carton |
| 6/8 | \$249.32 | \$261.78 | \$286.72 | \$361.52 |
| 8/0 | \$267.56 | \$280.94 | \$307.70 | \$387.96 |
| 2-1/2" X 6-9/16" | Full Pallet (60 pcs) | Half Pallet (30 pcs) | Carton Pack (15 pcs) | Less Than Carton |
| 6/8 | \$400.00 | \$420.00 | \$460.00 | \$580.00 |
| 8/0 | \$434.28 | \$456.00 | \$499.42 | \$629.72 |

| MULL POST - FULL COMPOSITE | | | | |
|----------------------------|-----------------------------|-----------------------------|-----------------------------|-------------------------|
| **2-1/2" X 6-9/16" | Full Pallet (60 pcs) | Half Pallet (30 pcs) | Carton Pack (15 pcs) | Less Than Carton |
| 6/8 | \$328.42 | \$344.84 | \$377.68 | \$476.22 |
| 8/0 | \$369.38 | \$387.86 | \$424.80 | \$535.62 |

** 2-1/2" X 6-9/16" Mull Post is back to back jambs mulled together

| MULL POST PREP ADDERS | | |
|-----------------------|-----------------------|---------|
| Mull Post | *Sill Haunch | \$32.82 |
| 6/8 | Hinge | \$4.59 |
| | Strike | \$4.59 |
| | Weatherstrip one side | \$12.20 |
| 8/0 | Hinge | \$4.59 |
| | Strike | \$4.59 |
| | Weatherstrip one side | \$15.00 |

* SILL HAUNCH - THERE WILL BE A \$50.00 SETUP CHARGE FOR LESS THAN 50 MULL POSTS PER ORDER



Primed Composite

| DOOR AND SIDELITE HEADER UP TO 14" x 3/0 | | | | |
|--|----------------------|----------------------|----------------------|------------------|
| | Full Pallet (50 Pcs) | Half Pallet (25 Pcs) | Carton Pack (15 Pcs) | Less Than Carton |
| 4-9/16" | \$76.64 | \$80.46 | \$88.12 | \$111.12 |
| 6-9/16" | \$122.92 | \$129.06 | \$141.36 | \$178.22 |

| DOOR AND SIDELITE HEADER UP TO 14" x 3/0 x 14" | | | | |
|--|----------------------|----------------------|----------------------|------------------|
| | Full Pallet (50 Pcs) | Half Pallet (25 Pcs) | Carton Pack (15 Pcs) | Less Than Carton |
| 4-9/16" | \$87.80 | \$82.20 | \$100.98 | \$127.32 |
| 6-9/16" | \$125.00 | \$131.24 | \$143.74 | \$181.24 |

| 6/0 PATIO HEADER | | | | |
|------------------|----------------------|----------------------|----------------------|------------------|
| | Full Pallet (50 Pcs) | Half Pallet (25 Pcs) | Carton Pack (15 Pcs) | Less Than Carton |
| 4-9/16" | \$84.30 | \$88.50 | \$96.94 | \$122.22 |
| 6-9/16" | \$111.74 | \$117.32 | \$128.50 | \$162.02 |

| PRIMED MULL CAP | | | | |
|-----------------|-----------------------|----------------------|----------------------|------------------|
| | Full Pallet (100 Pcs) | Half Pallet (50 Pcs) | Carton Pack (20 Pcs) | Less Than Carton |
| 1" X 1-1/2" | | | | |
| 8/0 | \$45.32 | \$47.58 | \$52.12 | \$65.72 |

| PRIMED SIDELITE STOP | | | | |
|----------------------|-----------------|----------|----------------------|------------------|
| | Boxed (100 Pcs) | (50 Pcs) | Carton Pack (20 Pcs) | Less Than Carton |
| 8/0 | \$15.38 | \$16.16 | \$17.70 | \$22.30 |

| 3/4" PRIMED FLAT JAMBS | | | | | | |
|------------------------|-------------|---------------|-------------|---------------|----------------------|------------------|
| | Full Pallet | | Half Pallet | | Carton Pack (20 Pcs) | Less Than Carton |
| 4-9/16" X 83" | \$49.26 | (360 Per PLT) | \$51.72 | (180 Per PLT) | \$56.64 | \$71.42 |
| 4-9/16" X 99" | \$60.10 | (360 Per PLT) | \$63.10 | (180 Per PLT) | \$69.12 | \$87.16 |
| 6-9/16" X 83" | \$75.74 | (180 Per PLT) | \$79.52 | (90 Per PLT) | \$87.10 | \$109.82 |
| 6-9/16" X 99" | \$90.34 | (180 Per PLT) | \$94.86 | (90 Per PLT) | \$103.88 | \$130.98 |

BROKEN PALLET CHARGES:
 Standard Size \$40.00 Net
 14' - 17' Pallet \$70.00 Net
 17' - 19' Pallet \$100.00 Net

FREIGHT CHARGES:
 Composite Only:

Prepaid freight on minimum orders of \$22,000.00 or more to single location

Clad and Composite:

If minimum clad order of \$3,200.00 is met, you can top load composite frames.
 Freight will be prepaid.



Woodgrain Composite

| WOODGRAIN COMPOSITE PRICING | | | | | | |
|-----------------------------|-------------|---------------|-------------|---------------|----------------------|------------------|
| NON PREPPED JAMB | | | | | | |
| 4-9/16" Jamb | Full Pallet | | Half Pallet | | Carton Pack (20 Pcs) | Less Than Carton |
| 2/8 or 3/0 | \$32.70 | (368 Per PLT) | \$34.34 | (184 Per PLT) | \$37.62 | \$47.42 |
| 6/8 | \$72.96 | (368 Per PLT) | \$76.60 | (184 Per PLT) | \$83.90 | \$105.78 |
| 8/0 | \$87.86 | (368 Per PLT) | \$92.24 | (184 Per PLT) | \$101.02 | \$127.38 |
| 12' lineal | N/A | N/A | N/A | N/A | \$147.98 | \$186.58 |
| 5-1/4" Jamb** | Full Pallet | | Half Pallet | | Carton Pack (20 Pcs) | Less Than Carton |
| 2/8 or 3/0 | \$45.26 | (240 Per PLT) | \$47.52 | (120 Per PLT) | \$52.04 | \$65.62 |
| 6/8 | \$104.52 | (240 Per PLT) | \$109.74 | (120 Per PLT) | \$120.20 | \$151.56 |
| 8/0 | \$124.62 | (240 Per PLT) | \$130.84 | (120 Per PLT) | \$143.30 | \$180.70 |
| 6-9/16" Jamb | Full Pallet | | Half Pallet | | Carton Pack (20 Pcs) | Less Than Carton |
| 2/8 or 3/0 | \$52.92 | (180 Per PLT) | \$55.58 | (90 Per PLT) | \$60.86 | \$76.74 |
| 6/8 | \$118.46 | (180 Per PLT) | \$124.38 | (90 Per PLT) | \$136.24 | \$171.78 |
| 8/0 | \$141.22 | (180 Per PLT) | \$148.28 | (90 Per PLT) | \$162.40 | \$204.78 |
| 12' lineal | N/A | N/A | N/A | N/A | \$240.90 | \$303.76 |
| 7-1/4" Jamb** | Full Pallet | | Half Pallet | | Carton Pack (20 Pcs) | Less Than Carton |
| 2/8 or 3/0 | \$73.38 | (180 Per PLT) | \$77.04 | (90 Per PLT) | \$84.38 | \$106.40 |
| 6/8 | \$169.72 | (180 Per PLT) | \$178.42 | (90 Per PLT) | \$195.40 | \$246.38 |
| 8/0 | \$202.74 | (180 Per PLT) | \$212.86 | (90 Per PLT) | \$233.14 | \$293.96 |

Pallet quantities are based on the same prep. i.e. 180 RT hand strike preps, 180 RT hand hinge preps.

****Some sizes may not be in stock. Please call Customer Service to verify.**

| MACHINING and WEATHERSTRIP ADDERS | | | | |
|-----------------------------------|---|---|--------------|--|
| | Prepping Charge: Sill Cut, Hinge and Latch | Installation Pilot Holes: Per Jamb or Head | Weatherstrip | Pilot Holes for Head and Sill Assembly |
| 3/0 Jamb Head (each) | | | \$6.25 | |
| 6/8 Jamb (each) | \$4.59 | \$4.59 | \$12.20 | \$4.59 |
| 8/0 Jamb (each) | \$4.59 | \$4.59 | \$15.00 | \$4.59 |

| KERF ADDER for Jamb (*Spline) | |
|-------------------------------|---------|
| 3/0 Jamb Head (each) | \$5.00 |
| 6/8 Jamb (each) | \$8.00 |
| 8/0 Jamb (each) | \$10.00 |

| KERF ADDER for BRICKMOULD (*Spline) | |
|-------------------------------------|---------|
| 3/0 BM Head (each) | \$5.00 |
| 6/8 BM (each) | \$8.00 |
| 8/0 BM (each) | \$10.00 |

* Note: spline not provided by FrontLine

| 180 woodgrain BRICKMOULD | | | | | | |
|--------------------------|-------------|---------------|-------------|---------------|----------------------|------------------|
| | Full Pallet | | Half Pallet | | Carton Pack (20 Pcs) | Less Than Carton |
| 3/0 | \$18.36 | (640 Per PLT) | \$19.14 | (320 Per PLT) | \$20.72 | \$25.44 |
| 6/8 | \$34.40 | (640 Per PLT) | \$36.10 | (320 Per PLT) | \$39.18 | \$48.72 |
| 8/0 | \$42.52 | (640 Per PLT) | \$44.52 | (320 Per PLT) | \$48.52 | \$60.50 |
| 17' Lineal | \$86.28 | (640 Per PLT) | \$90.46 | (320 Per PLT) | \$98.82 | \$123.92 |

Pallet Quantities are based on all right verticals or all left verticals.



Woodgrain Composite

| MULL POST - LVL REINFORCEMENT | | | | |
|-------------------------------|-----------------------------|-----------------------------|-----------------------------|-------------------------|
| 2" X 4-3/8" | Full Pallet (90 Pcs) | Half Pallet (45 Pcs) | Carton Pack (20 Pcs) | Less Than Carton |
| 6/8 | \$270.34 | \$283.86 | \$310.88 | \$391.98 |
| 8/0 | \$290.30 | \$304.82 | \$333.84 | \$420.94 |
| 2-1/2" X 4-3/8" | Full Pallet (90 Pcs) | Half Pallet (45 Pcs) | Carton Pack (20 Pcs) | Less Than Carton |
| 6/8 | \$270.34 | \$283.86 | \$310.88 | \$391.98 |
| 8/0 | \$290.30 | \$304.82 | \$333.84 | \$420.94 |
| 2-1/2" X 4-9/16" | Full Pallet (90 Pcs) | Half Pallet (45 Pcs) | Carton Pack (20 Pcs) | Less Than Carton |
| 6/8 | \$270.34 | \$283.86 | \$310.88 | \$391.98 |
| 8/0 | \$290.30 | \$304.82 | \$333.84 | \$420.94 |
| 2-1/2" X 6-9/16" | Full Pallet (60 pcs) | Half Pallet (30 pcs) | Carton Pack (15 pcs) | Less Than Carton |
| 6/8 | \$420.00 | \$441.00 | \$483.00 | \$609.00 |
| 8/0 | \$454.28 | \$477.00 | \$522.42 | \$658.72 |
| MULL POST - FULL COMPOSITE | | | | |
| **2-1/2" X 6-9/16" | Full Pallet (60 Pcs) | Half Pallet (30 Pcs) | Carton Pack (15 Pcs) | Less Than Carton |
| 6/8 | \$367.16 | \$385.50 | \$422.22 | \$532.36 |
| 8/0 | \$409.42 | \$429.88 | \$470.82 | \$593.64 |

** 2-1/2" X 6-9/16" Mull Post is back to back jambs mulled together

| MULL POST PREP ADDERS | | |
|-----------------------|-----------------------|---------|
| Mull Post | *Sill Haunch | \$32.82 |
| 6/8 | Hinge | \$4.59 |
| | Strike | \$4.59 |
| | Weatherstrip one side | \$12.20 |
| 8/0 | Hinge | \$4.59 |
| | Strike | \$4.59 |
| | Weatherstrip one side | \$15.00 |

* SILL HAUNCH - THERE WILL BE A \$50.00 SETUP CHARGE FOR LESS THAN 50 MULL POSTS PER ORDER



Woodgrain Composite

| DOOR AND SIDELITE HEADER UP TO 14" x 3/0 | | | | |
|--|----------------------|----------------------|----------------------|------------------|
| | Full Pallet (50 Pcs) | Half Pallet (25 Pcs) | Carton Pack (15 Pcs) | Less Than Carton |
| 4-9/16" | \$100.90 | \$105.94 | \$116.04 | \$146.30 |
| 6-9/16" | \$145.28 | \$152.56 | \$167.08 | \$210.66 |

| DOOR AND SIDELITE HEADER UP TO 14" x 3/0 x 14" | | | | |
|--|----------------------|----------------------|----------------------|------------------|
| | Full Pallet (50 Pcs) | Half Pallet (25 Pcs) | Carton Pack (15 Pcs) | Less Than Carton |
| 4-9/16" | \$115.66 | \$121.44 | \$133.02 | \$167.70 |
| 6-9/16" | \$163.84 | \$172.02 | \$188.42 | \$237.56 |

| 6/0 PATIO HEADER | | | | |
|------------------|----------------------|----------------------|----------------------|------------------|
| | Full Pallet (50 Pcs) | Half Pallet (25 Pcs) | Carton Pack (15 Pcs) | Less Than Carton |
| 4-9/16" | \$155.66 | \$121.44 | \$133.02 | \$167.70 |
| 6-9/16" | \$160.42 | \$168.44 | \$184.48 | \$232.62 |

| WOODGRAIN MULL CAP | | | | |
|--------------------|-----------------------|----------------------|----------------------|------------------|
| 1" X 1-1/2" | Full Pallet (100 Pcs) | Half Pallet (50 Pcs) | Carton Pack (20 Pcs) | Less Than Carton |
| 8/0 | \$52.06 | \$54.68 | \$59.88 | \$75.50 |

| WOODGRAIN SIDELITE STOP | | | | |
|-------------------------|-----------------|----------|----------------------|------------------|
| | Boxed (100 Pcs) | (50 Pcs) | Carton Pack (20 Pcs) | Less Than Carton |
| 8/0 | \$18.22 | \$19.14 | \$20.96 | \$26.42 |

| 3/4" WOODGRAIN FLAT JAMBS | | | | | | |
|---------------------------|-------------|---------------|-------------|---------------|----------------------|------------------|
| | Full Pallet | | Half Pallet | | Carton Pack (20 Pcs) | Less Than Carton |
| 4-9/16" X 83" | \$61.18 | (360 Per PLT) | \$64.24 | (180 Per PLT) | \$70.36 | \$88.72 |
| 4-9/16" X 99" | \$73.06 | (360 Per PLT) | \$76.72 | (180 Per PLT) | \$84.02 | \$105.94 |
| 6-9/16" X 83" | \$89.00 | (180 Per PLT) | \$93.44 | (90 Per PLT) | \$102.34 | \$129.04 |
| 6-9/16" X 99" | \$106.22 | (180 Per PLT) | \$111.54 | (90 Per PLT) | \$122.16 | \$154.02 |

BROKEN PALLET CHARGES:
 Standard Size \$40.00 Net
 14' - 17' Pallet \$70.00 Net
 17' - 19' Pallet \$100.00 Net

FREIGHT CHARGES:
 Composite Only: Prepaid freight on minimum orders of \$22,000.00 or more to single location

Clad and Composite: If minimum clad order of \$3,200.00 is met, you can top load composite frames.
 Freight will be prepaid.



Whitecap Composite

| WHITE CAP COMPOSITE PRICING | | | | | | |
|-----------------------------|-------------|---------------|-------------|---------------|----------------------|------------------|
| NON PREPPED JAMB | | | | | | |
| 4-9/16" Jamb | Full Pallet | | Half Pallet | | Carton Pack (20 Pcs) | Less Than Carton |
| 2/8 or 3/0 | \$31.26 | (368 Per PLT) | \$32.82 | (184 Per PLT) | \$35.96 | \$45.34 |
| 6/8 | \$69.74 | (368 Per PLT) | \$73.22 | (184 Per PLT) | \$80.20 | \$101.12 |
| 8/0 | \$83.98 | (368 Per PLT) | \$88.18 | (184 Per PLT) | \$96.58 | \$121.76 |
| 12' lineal | N/A | N/A | N/A | N/A | \$141.44 | \$178.34 |
| 5-1/4" Jamb** | Full Pallet | | Half Pallet | | Carton Pack (20 Pcs) | Less Than Carton |
| 2/8 or 3/0 | \$43.26 | (240 Per PLT) | \$45.42 | (120 Per PLT) | \$49.74 | \$62.72 |
| 6/8 | \$99.92 | (240 Per PLT) | \$104.90 | (120 Per PLT) | \$114.90 | \$144.86 |
| 8/0 | \$119.12 | (240 Per PLT) | \$125.08 | (120 Per PLT) | \$139.98 | \$172.72 |
| 6-9/16" Jamb | Full Pallet | | Half Pallet | | Carton Pack (20 Pcs) | Less Than Carton |
| 2/8 or 3/0 | \$49.86 | (180 Per PLT) | \$52.36 | (90 Per PLT) | \$57.34 | \$72.30 |
| 6/8 | \$111.60 | (180 Per PLT) | \$117.18 | (90 Per PLT) | \$128.34 | \$161.82 |
| 8/0 | \$133.04 | (180 Per PLT) | \$139.68 | (90 Per PLT) | \$152.98 | \$192.90 |
| 12' lineal | N/A | N/A | N/A | N/A | \$226.94 | \$286.14 |
| 7-1/4" Jamb** | Full Pallet | | Half Pallet | | Carton Pack (20 Pcs) | Less Than Carton |
| 2/8 or 3/0 | \$73.38 | (180 Per PLT) | \$77.04 | (90 Per PLT) | \$84.38 | \$106.40 |
| 6/8 | \$169.92 | (180 Per PLT) | \$179.02 | (90 Per PLT) | \$195.40 | \$246.38 |
| 8/0 | \$202.74 | (180 Per PLT) | \$212.86 | (90 Per PLT) | \$233.14 | \$293.96 |

Pallet quantities are based on the same prep. i.e. 180 RT hand strike preps, 180 RT hand hinge preps.

****Some sizes may not be in stock. Please call Customer Service to verify.**

| MACHINING and WEATHERSTRIP ADDERS | | | | |
|-----------------------------------|---|---|--------------|---|
| | Prepping Charge: Sill Cut, Hinge and Latch | Installation Pilot Holes: Per Jamb or Head | Weatherstrip | Pilot Holes for Head and Sill Assembly |
| 3/0 Jamb Head (each) | | | \$6.25 | |
| 6/8 Jamb (each) | \$4.59 | \$4.59 | \$12.20 | \$4.59 |
| 8/0 Jamb (each) | \$4.59 | \$4.59 | \$15.00 | \$4.59 |

| KERF ADDER for Jamb (*Spline) | |
|-------------------------------|---------|
| 3/0 Jamb Head (each) | \$5.00 |
| 6/8 Jamb (each) | \$8.00 |
| 8/0 Jamb (each) | \$10.00 |

| KERF ADDER for BRICKMOULD (*Spline) | |
|-------------------------------------|---------|
| 3/0 BM Head (each) | \$5.00 |
| 6/8 BM (each) | \$8.00 |
| 8/0 BM (each) | \$10.00 |

* Note: spline not provided by FrontLine

| 180 WHITE CAP BRICKMOULD | | | | | | |
|--------------------------|-------------|---------------|-------------|---------------|----------------------|------------------|
| | Full Pallet | | Half Pallet | | Carton Pack (20 Pcs) | Less Than Carton |
| 3/0 | \$17.48 | (640 Per PLT) | \$18.22 | (320 Per PLT) | \$19.70 | \$24.18 |
| 6/8 | \$32.64 | (640 Per PLT) | \$34.14 | (320 Per PLT) | \$37.14 | \$46.16 |
| 8/0 | \$40.30 | (640 Per PLT) | \$42.20 | (320 Per PLT) | \$45.96 | \$57.28 |
| 17' Lineal | \$81.62 | (640 Per PLT) | \$85.58 | (320 Per PLT) | \$93.48 | \$117.18 |

Pallet Quantities are based on all right verticals or all left verticals.



Whitecap Composite

| MULL POST - LVL REINFORCEMENT | | | | |
|-------------------------------|----------------------|----------------------|----------------------|------------------|
| 2" X 4-3/8" | Full Pallet (90 Pcs) | Half Pallet (45 Pcs) | Carton Pack (20 Pcs) | Less Than Carton |
| 6/8 | \$258.40 | \$271.32 | \$297.18 | \$374.70 |
| 8/0 | \$277.50 | \$291.36 | \$319.12 | \$402.36 |
| 2-1/2" X 4-3/8" | Full Pallet (90 Pcs) | Half Pallet (45 Pcs) | Carton Pack (20 Pcs) | Less Than Carton |
| 6/8 | \$258.40 | \$271.32 | \$297.18 | \$374.70 |
| 8/0 | \$277.50 | \$291.36 | \$319.12 | \$402.36 |
| 2-1/2" X 4-9/16" | Full Pallet (90 Pcs) | Half Pallet (45 Pcs) | Carton Pack (20 Pcs) | Less Than Carton |
| 6/8 | \$258.40 | \$271.32 | \$297.18 | \$374.70 |
| 8/0 | \$277.50 | \$291.36 | \$319.12 | \$402.36 |
| 2-1/2" X 6-9/16" | Full Pallet (60 pcs) | Half Pallet (30 pcs) | Carton Pack (15 pcs) | Less Than Carton |
| 6/8 | \$411.42 | \$432.00 | \$473.14 | \$596.98 |
| 8/0 | \$445.72 | \$468.00 | \$512.58 | \$646.28 |

| MULL POST - FULL COMPOSITE | | | | |
|----------------------------|----------------------|----------------------|----------------------|------------------|
| **2-1/2" X 6-9/16" | Full Pallet (60 Pcs) | Half Pallet (30 Pcs) | Carton Pack (15 Pcs) | Less Than Carton |
| 6/8 | \$367.16 | \$385.50 | \$422.22 | \$532.36 |
| 8/0 | \$409.42 | \$429.88 | \$470.82 | \$593.64 |

** 2-1/2" X 6-9/16" Mull Post is back to back jambs mulled together

| MULL POST PREP ADDERS | | |
|-----------------------|-----------------------|---------|
| Mull Post | *Sill Haunch | \$32.82 |
| 6/8 | Hinge | \$4.59 |
| | Strike | \$4.59 |
| | Weatherstrip one side | \$12.20 |
| 8/0 | Hinge | \$4.59 |
| | Strike | \$4.59 |
| | Weatherstrip one side | \$15.00 |

* SILL HAUNCH - THERE WILL BE A \$50.00 SETUP CHARGE FOR LESS THAN 50 MULL POSTS PER ORDER



Whitecap Composite

| DOOR AND SIDELITE HEADER UP TO 14" X 3/0 | | | | |
|--|----------------------|----------------------|----------------------|------------------|
| | Full Pallet (50 Pcs) | Half Pallet (25 Pcs) | Carton Pack (15 Pcs) | Less Than Carton |
| 4-9/16" | \$83.20 | \$87.36 | \$95.68 | \$120.64 |
| 6-9/16" | \$128.34 | \$134.76 | \$147.58 | \$186.10 |

| DOOR AND SIDELITE HEADER UP TO 14" X 3/0 X 14" | | | | |
|--|----------------------|----------------------|----------------------|------------------|
| | Full Pallet (50 Pcs) | Half Pallet (25 Pcs) | Carton Pack (15 Pcs) | Less Than Carton |
| 4-9/16" | \$94.84 | \$99.58 | \$109.06 | \$137.52 |
| 6-9/16" | \$140.00 | \$147.00 | \$161.00 | \$203.00 |

| 6/0 PATIO HEADER | | | | |
|------------------|----------------------|----------------------|----------------------|------------------|
| | Full Pallet (50 Pcs) | Half Pallet (25 Pcs) | Carton Pack (15 Pcs) | Less Than Carton |
| 4-9/16" | \$92.98 | \$97.64 | \$106.94 | \$134.82 |
| 6-9/16" | \$137.50 | \$144.38 | \$158.14 | \$199.38 |

| WHITE PVC MULL CAP | | | | |
|--------------------|-----------------------|----------------------|----------------------|------------------|
| | Full Pallet (100 Pcs) | Half Pallet (50 Pcs) | Carton Pack (20 Pcs) | Less Than Carton |
| 1" X 1-1/2" | | | | |
| 99" | \$44.50 | \$46.72 | \$51.18 | \$64.52 |

| WHITE PVC SIDELITE STOP | | | | |
|-------------------------|-----------------|----------|----------------------|------------------|
| | Boxed (100 Pcs) | (50 Pcs) | Carton Pack (20 Pcs) | Less Than Carton |
| 8/0 | \$15.36 | \$16.12 | \$17.66 | \$22.28 |

BROKEN PALLET CHARGES:
 Standard Size \$40.00 Net
 10' - 16' Pallet \$70.00 Net
 14' - 17' Pallet \$100.00 Net

FREIGHT CHARGES:

Composite Only: Prepaid freight on minimum orders of \$22,000.00 or more to single location

Clad and Composite: If minimum clad order of \$3,200.00 is met, you can top load composite frames. Freight will be prepaid.



Composite Component Sizes

| COMPONENT SIZES | | |
|---------------------|--------------------|------------------------|
| 4-9/16" Jamb | Full Length | Pallet Quantity |
| 3/0 | 36" | 368 |
| 6/8 | 83" | 368 |
| 8/0 | 99" | 368 |
| 12' lineal | 144" | N/A |
| 5-1/4" Jamb | Full Length | Pallet Quantity |
| 3/0 | 36" | 240 |
| 6/8 | 83" | 240 |
| 8/0 | 99" | 240 |
| 6-9/16" Jamb | Full Length | Pallet Quantity |
| 3/0 | 36" | 180 |
| 6/8 | 83" | 180 |
| 8/0 | 99" | 180 |
| 12' lineal | 144" | N/A |
| 7-1/4" Jamb | Full Length | Pallet Quantity |
| 3/0 | 36" | 180 |
| 6/8 | 83" | 180 |
| 8/0 | 99" | 180 |

| MULL POST | | |
|-------------------------|--------------------|------------------------|
| 2" X 3-9/16" | Full Length | Pallet Quantity |
| 6/8 | 84" | 90 |
| 8/0 | 99" | 90 |
| 2-1/2" X 3-9/16" | Full Length | Pallet Quantity |
| 6/8 | 84" | 90 |
| 8/0 | 99" | 90 |
| 2-1/2" X 4-9/16" | Full Length | Pallet Quantity |
| 6/8 | 84" | 90 |
| 8/0 | 99" | 90 |
| 2-1/2" X 6-9/16" | Full Length | Pallet Quantity |
| 6/8 | 84" | 60 |
| 8/0 | 99" | 60 |

| 180 BRICKMOULD | | |
|----------------|--------------------|------------------------|
| | Full Length | Pallet Quantity |
| 3/0 | 40" | 640 |
| 6/8 | 84" | 640 |
| 8/0 | 102" | 640 |
| 17' Lineal | 204" | N/A |

| MULL CAP | | |
|--------------------|--------------------|------------------------|
| 1" X 1-1/2" | Full Length | Pallet Quantity |
| 8/0 | 99" | 980 |

| SIDELITE STOP | | |
|---------------|--------------|--------------|
| | Boxed | |
| 8/0 | 98" | (100 pieces) |



Limited Lifetime Warranty

FRONTLINE® BLDG. PRODUCTS INC. - COMPOSITE FRAME

DECEMBER 2019

Terms and Conditions

FrontLine® Bldg. Products, Inc., Composite Frames, as sold directly by FrontLine® Bldg. Products, Inc., are guaranteed to be free of defects in material and workmanship that might unreasonably affect its performance. The terms of this Limited Lifetime Warranty extends from the first date of purchase for the life of the product.

***This warranty is for the original owner of the product and is non-transferable.**

The terms of this Limited Warranty exclude failures, which are the result of or involve:

1. Accident, negligence, abuse or improper use or installed in unusual, abnormal or extreme locations or situations.
2. Stress caused by localized application of heat, movement of building or building components, or expansion/contraction of building or building components.
3. Damage caused by freight carriers, common carriers, private transportation, or any other means of transportation or handling, occurring after shipping from FrontLine® Bldg. Products, Inc.
4. Damage to surfaces caused by fire, corrosive fumes, stains, contact with chemically abrasive substances, airborne pollutants, sanding, improper washing, extreme elements, acts of God and / or any event not controlled by FrontLine® Bldg. Products, Inc.
5. Damage done deliberately, by negligence, abnormal working conditions, or failure to follow instructions regarding staining, painting or installations or what is considered normal wear and tear.
6. Custom surface finishes or alternations applied to product(s) in the field.
7. Door hardware is not warranted.
8. Improper or insufficient handling, storage, installation, maintenance, or service.
9. All components, parts, and labor supplied by parties other than FrontLine® Bldg. Products, Inc. or its agents.

FrontLine® Bldg. Products, Inc. warrants the **Composite Frame** Product(s) free of defects in materials and workmanship and free of rot and decay during the warranty period for reasons covered by this warranty. If the **Composite Frame** Product that is the subject of this Limited Lifetime warranty fails during the warrant period for reasons covered by the Limited Lifetime Warranty and the original purchaser submits the written service request required under this Limited Lifetime Warranty, FrontLine® Bldg. Products, Inc. will: **Replace the Composite Frame product with a product that is functionally at least equal to the Composite Frame product being replaced, or provide in U.S. dollars the value of the frame as listed on the FrontLine® Bldg. Products, Inc. price list at the time of failure.**

Warranty Claim Procedures

To place a warranty claim, the purchaser shall notify the Corporate Office of FrontLine® Bldg. Products, Inc. by providing the following information presented in writing:

1. Product ID and description of the Frame;
2. Proof of purchase (invoice and delivery ticket provided by FrontLine® Bldg. Products, Inc.); and
3. Detailed description of defect(s).
4. A copy of this Limited Lifetime Warranty

Claimed defective Composite Frame may be inspected by a FrontLine® Bldg. Products, Inc. representative, and customer must permit the inspection when requested by FrontLine® Bldg. Products, Inc., or any claims shall be deemed waived. All disputes regarding this Limited Lifetime Warranty will be exclusive venue and jurisdiction in Brown County, in the state of Wisconsin.

Corporate Office

FrontLine® Bldg. Products, Inc.
1100 S. Huron Rd, Green Bay, WI 54311
Phone: (920) 393-1340 / Fax: (920) 227-9591



When a defect occurs, in conformity to the warranty terms set above, FrontLine® Bldg. Products, Inc. agrees to either replace the Frame or refund the original purchase price at FrontLine® Bldg. Products, Inc.'s election. In the event FrontLine® Bldg. Products, Inc. elects to provide a replacement, the Limited Warranty of the replacement will extend only for the balance of the original Warranty period. In no event shall FrontLine® Bldg. Products, Inc. be responsible for costs and any charges involving the shipping, finishing and installation of the replacement Composite Frame.

FrontLine® Bldg. Products, Inc. will perform its obligations under the Warranty within thirty (30) days after receipt of appropriate notice, inspection and confirmation of the existence of a defect.

FrontLine® Bldg. Products, Inc. will not be liable for any Frames repaired or replaced without its prior written consent.

The remedies set forth herein are the original purchaser's exclusive remedies for breach of Warranty. In no case shall FrontLine® Bldg. Products, Inc. be liable for any general, incidental or consequential damages. There are no other Warranties except as set forth herein. If FrontLine® Bldg. Products, Inc. determines the Composite Frames are defective within the terms of the warranty, FrontLine® Bldg. Products, Inc. will either (a) repair the Composite Frames without charge, (b) furnish a replacement of the Composite Frames from stock (installation and/or labor costs of the replacement Composite Frames is not included), or (c) refund the purchase price of the product in lieu of furnishing a replacement.

If FrontLine® Bldg. Products, Inc. elects to provide a replacement, the Limited Warranty of the replacement will extend only for the balance of the original warranty period. If the original owner fails to provide satisfactory proof of the date of the purchase, the date of manufacture shall be used instead.

***FrontLine® Bldg. Products, Inc. reserves the right to modify the conditions and restrictions of this warranty without prior notice.**

Corporate Office

FrontLine® Bldg. Products, Inc.
1100 S. Huron Rd, Green Bay, WI 54311
Phone: (920) 393-1340 / Fax: (920) 227-9591



TAB 9: PRICING GARAGE DOOR FRAME

(after page 49)

Garage Door Frames

- Pro-Series (all aluminum frame) available in 90° & 45° corners. The all aluminum frame is also available as an Arch Top. These frames come KD and are individually packaged. (Optional 1x4 add on casing and J-Mould).
- The arch top frames are only available in the Pro-Series crownline casing.
- Packaging is durable to eliminate damage in shipping. The frames are pre-packaged with all installation hardware and full color instructions.
- Readily available in 11 standard colors. Arctic Silver is not available for Pro-Series and Arch Top. **Black now available on Arch Top frames.**
- Pro-Series offers proven performance with the no rot all aluminum frame, very easy to install with heavy duty corner gussets. The gusseted corners give a perfect miter and strength for efficient field assembly.

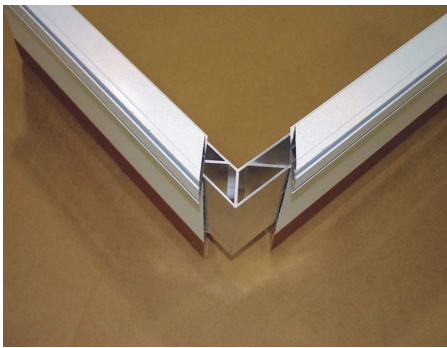

Pro-Series

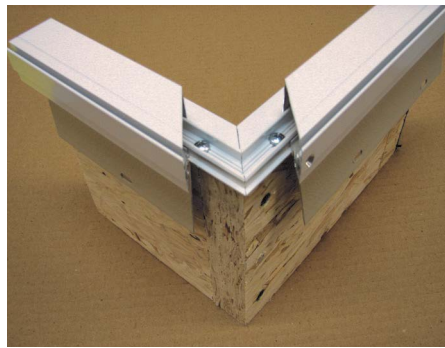

**Pro-Series Intermediate
Jamb Size | 90° Only**



45° Corner

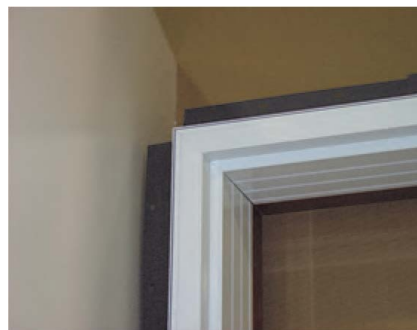

90° Corner



Arch Top

Garage Door Frames

Ordering Garage Door Frames:

1. **Choose Product Design Type**
 - 90° Corners, 45° Corners or Arched Top

2. **Choose Trim Style**
 - Standard Crownline casing
 - Optional J-Mould that converts the casing to Brickmould
 - Optional 1x4 Trim Board add on casing

3. **Determine Size(s)**
 - Frame size is Determined by size of garage door. Example: 9x8, 16x7, 12x12

4. **Confirm Jamb Depth**
 - Typical 2x4 construction = 5-1/2" jamb
 - Typical 2x6 construction = 7-1/2" jamb
 - Most jamb depths can be accommodated

5. **Confirm Rough Opening**
 - Add 3" to the width & 1-1/2" to the height of door size

6. **Choose Color**
 - 11 Standard Colors (Pro-Series)

Pro-Series

All Aluminum Garage Door Frame 90° & 45° Corners

List prices. Subject to discount.

Standard Size Frames:

| | Crowline Nosing | | | | Options | | |
|-------------|----------------------|----------|----------------------|------------|----------|-----------------|------------------------------|
| | 5-1/2" for 2x4 walls | | 7-1/2" for 2x6 walls | | J-Mould | 1x4 add on Trim | 1x4 add on Trim with J-Mould |
| | 90° | 45° | 90° | 45° | | | |
| 8x7 | \$506.88 | \$656.64 | \$728.64 | \$878.40 | \$118.08 | \$235.36 | \$353.44 |
| 9x7 | \$529.92 | \$679.68 | \$761.76 | \$911.52 | \$123.06 | \$245.12 | \$368.18 |
| 10x7 | \$552.96 | \$702.72 | \$794.88 | \$944.64 | \$127.92 | \$254.10 | \$382.02 |
| 16x7 | \$691.20 | \$840.96 | \$993.60 | \$1,143.36 | \$158.00 | \$314.24 | \$472.24 |
| 18x7 | \$737.28 | \$887.04 | \$1,059.84 | \$1,209.60 | \$168.00 | \$334.00 | \$502.00 |
| 8x8 | \$552.96 | \$702.72 | \$794.88 | \$944.64 | \$128.04 | \$254.08 | \$382.12 |
| 9x8 | \$576.00 | \$725.76 | \$828.00 | \$977.76 | \$133.02 | \$263.84 | \$396.86 |
| 10x8 | \$599.04 | \$748.80 | \$861.12 | \$1,010.88 | \$138.00 | \$272.82 | \$410.82 |
| 16x8 | \$737.28 | \$887.04 | \$1,059.84 | \$1,209.60 | \$167.96 | \$332.96 | \$500.92 |
| 18x8 | \$783.36 | \$933.12 | \$1,126.08 | \$1,275.84 | \$177.96 | \$352.72 | \$530.68 |

Rough Opening - add 3" in width and 1-1/2" in height

Non-Standard Sizes:

Any frame not listed above.

| | |
|---|---------------------|
| Standard 2x4 wall and jamb depth of 5-1/2" | \$27.20 / LF |
| Standard 2x6 wall and jamb depth of 7-1/2" | \$39.20 / LF |
| 45° corners 5-1/2" & 7-1/2" Only Add per frame. | \$160.00 |

Jamb Depths less than 5-1/2" Add \$220.00 List to the 5.5 frame price.

Jamb Depths 5-1/2" & less than 7-1/2" . . . Add \$220.00 List to the 7.5 frame price.

Jamb Depths 7-9/16" & less than 9-1/2" . . . Add \$24.00 List per LF to the 7.5 frame price.

Jamb Depths 9-9/16" up to 11-1/2" Add \$48.00 List per LF to the 7.5 frame price.

Standard Colors:

White, Sandstone, Bronze, Bahama Brown, Green, Terratone, Almond, Eggshell, Wineberry, Beige and Black.

To Order Specify:

1. Color
2. Rough opening size, (R.O. add 3" to width and 1-1/2" to height).
3. 90° or 45° corners.
4. 5-1/2" or 7-1/2" jamb depth.

Limited Lifetime Warranty



Pro-Series

All Aluminum Arch Top Frames

List prices. Subject to discount.

Standard Size Frames:

Standard rise in the center of the arch is 10". Available in Crownline nosing only. Any radius other than 10" call for a quote.

| | 5-1/2" for 2x4 walls | 7-1/2" for 2x6 walls |
|-------|----------------------|----------------------|
| 8x7 | \$1,074.10 | \$1,385.72 |
| 9x7 | \$1,095.36 | \$1,406.94 |
| 10x7 | \$1,120.12 | \$1,456.54 |
| 16x7 | \$1,226.34 | \$1,588.72 |
| 18x7 | \$1,306.62 | \$1,666.62 |
| <hr/> | | |
| 8x8 | \$1,109.52 | \$1,451.80 |
| 9x8 | \$1,130.74 | \$1,473.06 |
| 10x8 | \$1,154.36 | \$1,487.20 |
| 16x8 | \$1,274.74 | \$1,652.46 |
| 18x8 | \$1,350.28 | \$1,737.44 |

Rough Opening - add 3" in width and 1-1/2" in height

Standard Colors:

White, Sandstone, Bronze, Bahama Brown, Green, Terratone, Almond, Eggshell, Wineberry, Beige and Black.

To Order Specify:

1. Color.
2. Rough opening size, (R.O. add 3" to width and 1-1/2" to height).
3. 10" rise or special order 12" rise.
4. 5-1/2" or 7-1/2" jamb depth only.

Limited Lifetime Warranty



ULTIMATE-SERIES ALUMINUM GARAGE DOOR FRAME

FOR NEW OR EXISTING GARAGE DOOR FRAMES





90° & 45° FRAMES | FEATURES:

- Available with 90° square or 45° clipped corners
- Heavy-duty extruded aluminum for strength and durability
- Standard with Brickmould nosing, or choose our optional Crownline nosing. Available to add our 3-1/2" flat casing or J-Mould
- One piece jamb depth up to 7-1/2", greater than 7-1/2" will be two pieces
- Matches the FrontLine® Entry Door for both entry and patio door frames while also complimenting all window frame systems available in market
- Limited Lifetime Warranty

SIZES AND COLORS

- Any width up to 18' and height up to 18' available
- Stock colors - White*, Black*, Sandstone*, Bahama Brown*, Bronze*, Terratone*, Green*, Almond*, Eggshell, Beige, Iron Ore and Wineberry



90° Square Corner



45° Clipped Corner



Standard Kit Components



Crownline Nosing



White* Eggshell Almond* Beige Sandstone* Terratone*



Bronze* Bahama Brown* Black* Iron Ore Wineberry Green*



J-Mould
For use with Crownline only



3-1/2" Flat Casing
For use with Crownline only

**One piece jamb available up to 7-1/2"*



DISTRIBUTED BY:



Connect with Us

- www.frontlinebldg.com
- sales@frontlinebldg.com
- 1-920-393-1340
- [Facebook](#) [LinkedIn](#) [YouTube](#)

Ultimate-Series Garage Door Frame

***Clad over existing wood jamb with jamb cover and nosing, includes 1 piece headers**

List prices. Subject to discount.

Standard Size Frames:

All material is stock cut. Requires cutting the verticals to length and 1 miter cut on the header. For any sizes not shown below please call for quote.

| | Brickmould Nosing | | | | Crownline Nosing | | | |
|-------------|----------------------|----------|----------------------|-------------|----------------------|----------|----------------------|-------------|
| | 5-1/2" for 2x4 walls | | 7-1/2" for 2x6 walls | | 5-1/2" for 2x4 walls | | 7-1/2" for 2x6 walls | |
| | 90° | 45° | 90° | 45° | 90° | 45° | 90° | 45° |
| 8x8 | \$474.24 | \$624.00 | *\$699.84 | *\$849.60 | \$455.52 | \$605.28 | *\$681.12 | *\$830.88 |
| 9x8 | \$494.00 | \$643.76 | *\$729.00 | *\$878.76 | \$474.50 | \$624.26 | *\$709.50 | *\$859.26 |
| 10x8 | \$513.76 | \$663.52 | *\$758.16 | *\$907.92 | \$493.48 | \$643.24 | *\$737.88 | *\$887.64 |
| 16x8 | \$632.32 | \$782.08 | *\$933.12 | *\$1,082.88 | \$607.36 | \$757.12 | *\$908.16 | *\$1,057.92 |
| 18x8 | \$671.84 | \$821.60 | *\$991.40 | *\$1,141.20 | \$645.32 | \$795.08 | *\$964.92 | *\$1,114.68 |

The actual aluminum coverage for above is (4-1/2) for a 5-1/2" jamb depth and (6-1/2") for 7-1/2" jamb depth.

The exposed wood is where the overhead door seal gets nailed onto the wood jamb.

***One Piece 8-9/16" Jamb Cover Provided**

Colors Available: White, Sandstone, Bronze, Bahama Brown, Green, Terratone, Almond & Black

Options (add on casings applied to Crownline only):

Note: You must allow for the extra length at the miter, example = 9x8 (10' header, 9' verticals).

| | | |
|-------------------------|-------------------|---------------------------|
| 3-1/2" Casing (FLTA-47) | J-Mould (FLTA-48) | 3-1/2" Casing w / J-Mould |
| \$10.60 LF | \$5.40 LF | \$16.00 LF |

Standard Colors:

White, Sandstone, Bronze, Bahama Brown, Green, Terratone, Almond, Eggshell, Wineberry, Beige, Iron Ore, Arctic Silver and Black.

To Order Specify:

1. Color.
2. Rough opening size, (R.O. add 3" to width and 1-1/2" to height).
3. 90° or 45° corners.
4. 5-1/2" or 7-1/2" jamb depth.
5. Please call customer service for a quote on any jamb depth other than 5-1/2" or 7-1/2".

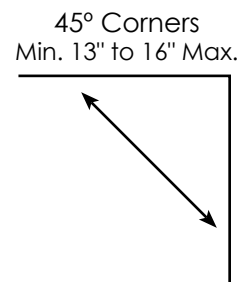

Clad Order Form

Customer _____ Date _____

Job Name _____

PO/WO Number _____

CLAD GARAGE DOOR FRAME FINISHED OPENING MEASUREMENTS

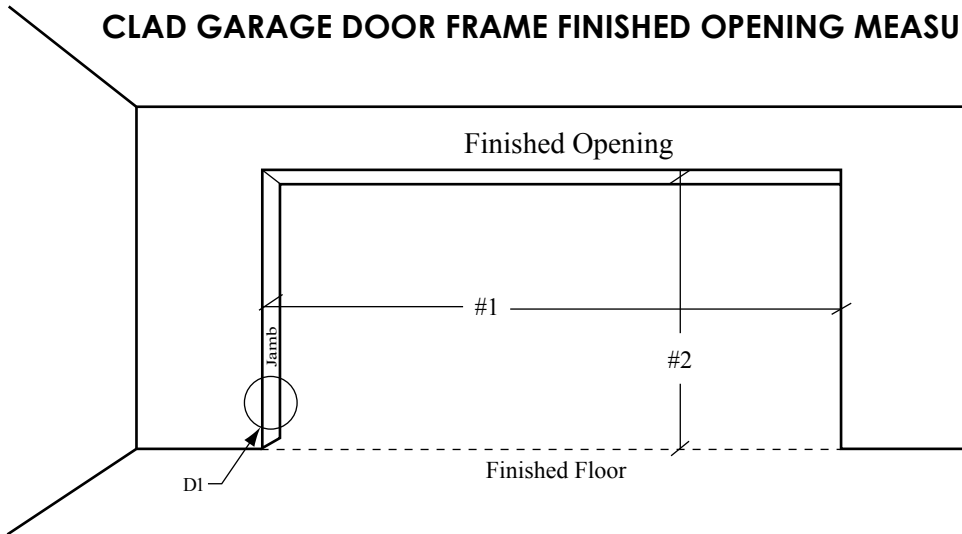

Please check appropriate box:

Brickmould

Crownline

Slimline

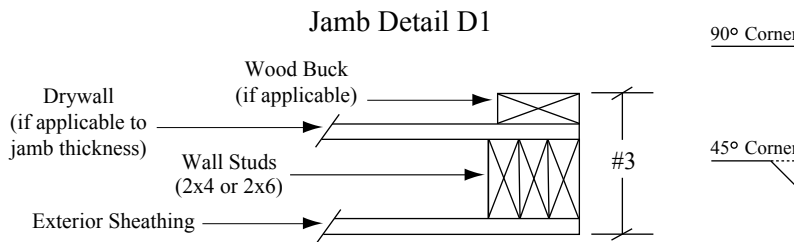

FINISHED OPENING MEASUREMENTS

1 Width _____

2 Height _____

3 Jamb Depth _____

4 Quantity _____

Stock Cut _____ (miter cut one end)

OR
Finished Cut _____ (all miters cut)

Color _____

Corner 90° _____

45° _____

FrontLine® Bldg. Products Inc.
1100 S. Huron Road
Green Bay, WI 54311
Phone: 920-393-1340
Fax: 920-227-9590

Requested Delivery Date _____

Ordered by _____



Installation Instructions for Garage Door Frame Cladding (Stock Cut)

Clad comes partially pre-cut for the garage door opening size. It is required to make one miter cut on the header, and also to cut floor angle off bottom of both verticals. To cut aluminum use a compound miter saw with a compound cut. For best results use a metal cutting blade with a five degree negative hook.

Figure #1:

Example of cladding for a 9' x 7' garage door frame. The Verticals are 7'3" pre-mitered with 3" left on length to cut floor angle. The Header is 9'6" pre-mitered on one end with opposite end left 6" longer to be cut in field to fit door header width. A miter cut is required on this end.

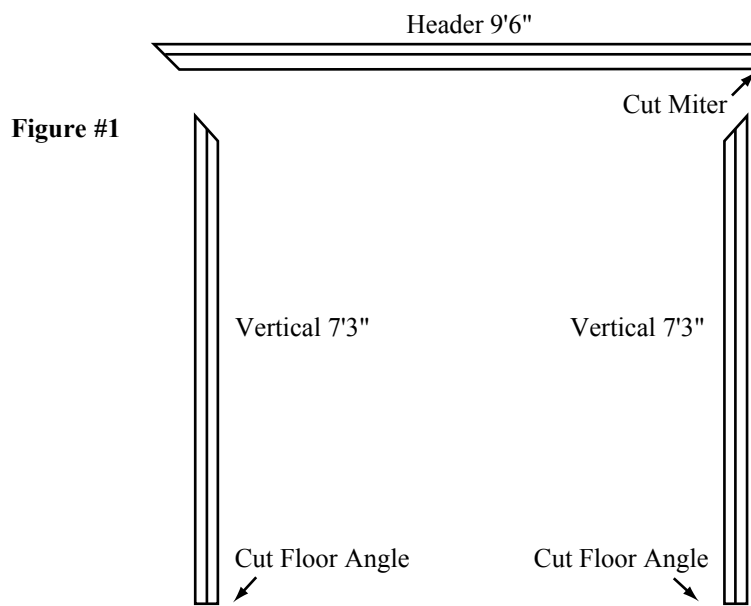
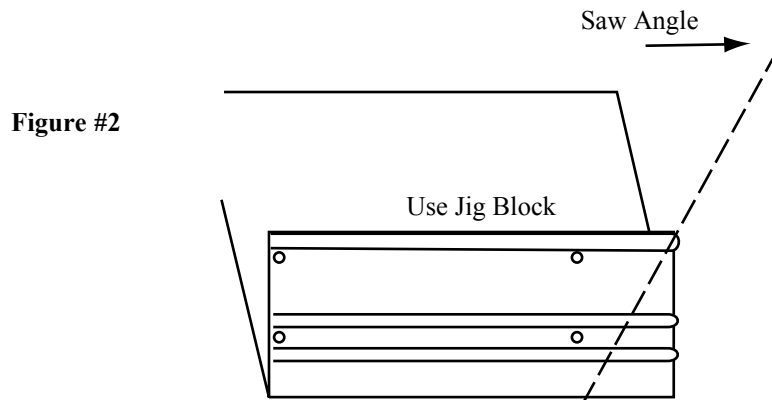

Figure #2:

Jamb cover must be miter cut using a jig block to support the aluminum angle of the jamb cover and to reduce saw blade chatter



TAB 10: SPECIALTY PRICING
(after page 58)

TRU-LOC™

WINDOW & DOOR INSTALLATION ANCHORS
RESISTING THE FORCES OF NATURE.™



EFFECTIVE - EASY TO USE - ADJUSTABLE - DURABLE



TRU-LOC CLIP

- Securely anchors the door system in the rough opening
- Simple to use
- Keeps the door system plumb and square
- No more drilling through sidelights
- Speeds up installation
- Install the door system right the first time
- Eliminates callbacks
- Saves money

Installation Instructions:

The TRU-LOC™ Window & Door Installation Anchor consists of two parts. Part "A", "the bracket", and Part "B" "the angle". (Figure 1)
If the unit you are installing has Part "A" pre-applied please move on to STEP TWO.

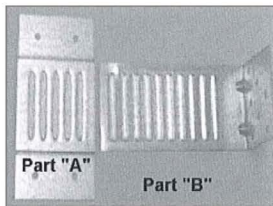

Figure 1



Figure 2

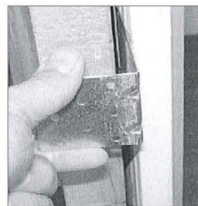

Figure 3



Figure 4

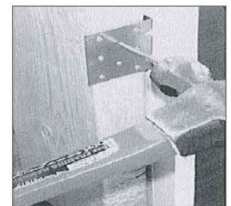

Figure 5

STEP ONE: Installation of Part "A" to the Jamb of the unit to be installed.

The bracket is mounted vertically to outer face of frame using #8 x 5/8" pan head screws. It is very important that the bracket is mounted squarely. The bracket is to be mounted no less than 1" and no more than 2" from the interior edge of the jamb. (Figure 2)

STEP TWO: Install unit into opening using conventional methods, making sure that unit is plumb and square in the opening. Conventional shims should be used to create a consistent reveal and proper operation.

STEP THREE: Now that the unit is properly located within the opening, insert the angle into the slot created between the bracket and the jamb. (Figure 3) The ribs on the face of both parts will interlock as the angle engages the bracket. Drive toward the stud or header. (Figure 4) Insert all angles into brackets and recheck door making sure its plumb and square before using nails to secure angles to framing member. (Figure 5) The TRU-LOC™ anchor is now installed and will effectively hold the unit in position increasing the longevity of proper operation and function.

TRU-LOC™ Anchors are designed to interlock very tightly, however if there is the need to remove the anchors after installation, the nails securing the angle to the framing member can be removed and the angle can be disengaged from the bracket by pulling it squarely from the bracket. The use of a small pry bar, claw hammer or pliers may offer some assistance in this removal.



www.frontlinebldg.com | sales@frontlinebldg.com | 920-393-1340

TRU-LOC™ Window & Door Installation Anchor

List prices. Subject to discount.

When an effective method is needed to securely anchor a window or door unit in its opening our revolutionary TRU-LOC™ hardware can be the answer.

| | |
|--|---------------------------------|
| Case of 250 bulk sets (Bracket & Angle) | List Price per case \$480.00 |
| Case of 100 bulk sets (Bracket & Angle) | List Price per case \$200.00 |
| (Screws are included in cost and packaged separately) | |
| Ctn. Of 24 Boxes (6 sets per box) | List Price per Ctn. \$360.00 |
| (Each box includes 24-5/8" screws & Instructions) | (\$15.00 per Box) |
| Ctn. Of 24 Boxes (8 sets per box) | List Price per Ctn. \$480.00 |
| (Each box includes 32-5/8" screws & Instructions) | (\$20.00 per Box) |
| Additional 5/8" Phillips pan head screw for installing bracket to jamb (Box of 500) | List Price \$25.00 |



List prices. Subject to discount.

Aluminum Clad Jamb Cover Screws

#8 x 3/4" Brad point screw (Box of 10,000) \$315.00 (net)
Easily drills through the jamb cover
between the nosing and locking points

Aluminum Clad Nosing Screws

#8-32 x 1" Phillips Flat Head Zinc machine thread \$0.12 each (net)

Aluma Lock Universal Corner Key

Brickmould corner key \$0.30 each (net)

Pro-Tex™ Protective Vinyl Cover

For use with Frontline® Bldg. Products Inc.

Crownline & Brickmould Nosing

Extruded aluminum cladding is becoming a standard for entry door frames. In today's maintenance free society, homeowners are more than willing to spend more money to achieve this freedom from maintenance. By the time the homeowner moves into their new home the entry system that you supplied weeks or even months ago has been handled multiple times and left unprotected in the opening during the construction process. PRO-TEX is an extra level of protection from the multitude of damage possibilities during this time.

The cost of this protection is a value, when your customers realize that you have saved them from potential service work and less than satisfied homeowners.

Crownline Cover List Price \$3.93 per 7' length
Packaged 100 pieces per carton
Brickmould Cover List Price \$4.09 per 7" length
Packaged 100 pieces per carton



NPC Sealants

List prices. Subject to discount.

We recommend NPC Sealant as the perfect complement to our Clad Program. Our stock includes our 11 clad colors, for a perfect match, in the #900 Solar Seal.

#900 Solar Seal

| | <u>List Price</u> | |
|---|-------------------|---------------|
| | 11 Oz. Tube | Per Case (12) |
| White/Clear | \$19.60 | \$227.00 |
| Bahama Brown, Sand, Beige, Terratone, Green, Almond Wineberry, Bronze, Black, or Iron Ore | \$19.90 | \$230.70 |
| Eggshell | \$32.00 | \$372.00 |

#900 Solar Seal

100% "Terpolymer" Adhesive/Sealant is formulated for long term performance on vinyl, cedar, metals, masonry, stucco, skylights, fiberglass, roof flashing and termination bars. It is a high performance alternative to urethane and silicone and is available in clear, white, black, and over 200 NPC standard siding and window colors.

- 300% elongation first year, 300% elongation twentieth year.
- Exceptional joint movement capability.
- Full U.V. protection.
- Tenacious long term adhesion.
- Paintable.
- Skins in one hour.
- Four-season application.



Solar Seal

TIP: After cutting a small tip on the tube and to keep sealant from drying out, keep tip submersed in water. This will keep sealant fresh and ready to use.

Touch-Up Paint

| | <u>List Price</u> |
|---|-------------------|
| 6 OZ Spray Can White, Bronze, Green, Sandstone, Bahama Brown, Terratone, Almond, Eggshell, Beige, Wineberry, Black | \$50.00 per can |
| 3 OZ Paint Pen White, Sandstone, Bronze, Bahama Brown, Green, Terratone, Almond, Eggshell, Wineberry, Black | \$24.00 per pen |



TAB 11: MISCELLANEOUS
(after page 63)



FRONTLINE® BLDG. PRODUCTS INC.

POINT-OF-SALE SHOWROOM DISPLAY



- Having a showroom touch point like the FrontLine® Point-of-Sale Showroom displays allows your customer to instantly recognize the value in selling entry doors which include the premium FrontLine® extruded aluminum frame system for protection. These displays support your sales efforts and reinforce the value of a maintenance-free exterior door frame with a Limited Lifetime Warranty.
- Exterior door frames built with FrontLine's® extruded aluminum cladding never require painting!
- It's a proven fact that displays create opportunities, opportunities turn into orders, and door orders which include FrontLine® cladding create a premium door system which homeowners will enjoy for years. FrontLine® Point-of-Sale Showroom Displays will create those opportunities and earn you the respect of your customers and additional dollars-per-door sold.
- FrontLine® Point-of-Sale Showroom Displays are sold on a 50/50 co-op basis with an additional discount for larger quantities. Contact FrontLine® or your FrontLine® sales representative for more information.



www.frontlinebldg.com | orders@frontlinebldg.com | 920-393-1340

©2020 FrontLine Bldg. Products Inc.

SC/P05/S0120



FRONTLINE[®] BLDG. PRODUCTS INC.

POINT OF SALE DISPLAY ORDER FORM

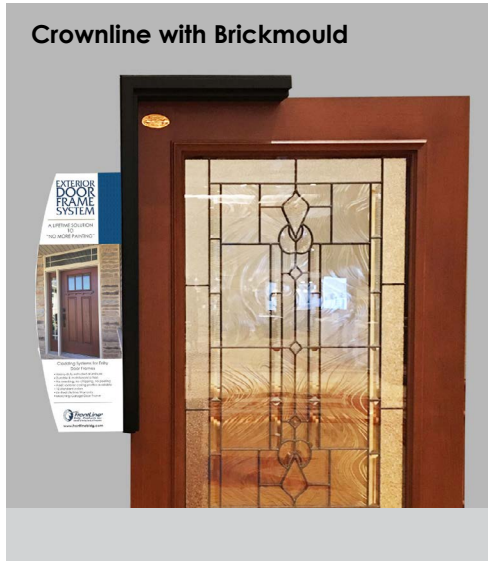

Head Display Sign



Active Display Sign

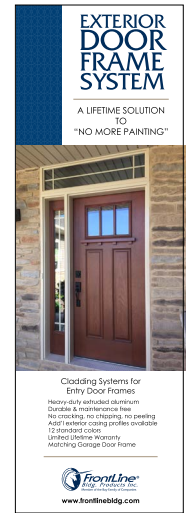

Distributor: _____ PO Number: _____

| FRONTLINE CLAD CORNER DISPLAY \$75.00 EA | |
|--|---|
| | Crownline with Brickmould Qty by Color |
| White | |
| Black | |

| FRONTLINE POS DOOR SIGNAGE | | | |
|----------------------------|---------|-----|-------|
| Sign | Cost | Qty | Total |
| HEAD DISPLAY SIGN | \$25.00 | | |
| ACTIVE DISPLAY SIGN | \$25.00 | | |

COLORS:

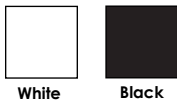

Note: Actual color may vary due to printing.

Dealer Signature: _____

Distributor Representative: _____

FrontLine Representative: _____

PO Number: _____



Please allow 2-4 weeks for delivery



www.frontlinebldg.com | orders@frontlinebldg.com | 920-393-1340

FrontLine Bldg. Products Inc. Sample Display Offering

| | |
|--|--|
| Garage Door Frame Table Top Display | \$30.00 Co-op Dollars can be used |
| *Choice of Pro-Series or Builder Series (Display has a backer card, side literature pocket with 25 brochures. Display shows jamb cover, crownline casing, brickmould casing, 3-1/2" Flat casing with J-mould) | |
| Entry Door Table Top Display | \$30.00 Co-op Dollars can be used |
| (Display has a backer card, side literature pocket with 25 brochures. Display shows jamb cover, crownline casing, brickmould casing attached, 3-1/2" Flat casing with J-mould, will ship loose in box) | |
| 12" Hand Samples | \$10.00 Co-op Dollars can be used |
| *Choice of Standard clad on wood jamb or Pre-Clad on composite (Display shows jamb cover, crownline, brickmould, 3-1/2" Flat casing with J-mould and color card) | |
| Pro-Series 12" KD Garage Door Frame | \$10.00 Co-op Dollars can be used |
| (Display consists of 12" header and sides, all KD and two corner gussets.) Will show ease of assembly | |
| FrontLine® Color Deck | \$12.00 |
| Aluminum sample of all 14 colors | |
| Color Chip Cards | No Charge |
| Shows actual paint chips of all the stocking colors | |
| All Sales Literature | No Charge |

| | |
|--|--------------------|
| Full Size Displays for Showrooms | 50% off Net |
| Showcase of Homes Clad and Garage Door Frames | 20% off Net |

**SAMPLES AND DISPLAYS WILL BE SHIPPED WITH OTHER ORDERS WHENEVER POSSIBLE.
SAMPLES AND DISPLAYS SHIPPED ALONE WILL INCUR SHIPPING CHARGES**

Co-op Program

Co-op dollars are established at the beginning of each calendar year and based upon ½ of one percent of the previous year's total purchases.

Example:

Total purchases in Previous Year: \$100,000
 $\$100,000 \times 0.005 = \500 co-op available for the Current calendar year

With FrontLine® approval, these co-op dollars may be used at each customer's discretion for marketing purposes. The following are examples of items covered by the FrontLine® co-op advertising program:

- Buying shows or dealer events
- All marketing materials, apparel with logo, sales aids with the FrontLine® logo printed on them
- Golf outings and customer appreciation events
- Door prizes

Buying shows, customer events and door prizes may be credited at 100%. Apparel and other items with the FrontLine® logo are credited at 50% or divided equally among the vendor participants.

Example:

Total cost of apparel purchase: \$500
 FrontLine credits customer 50% (\$250); Customer responsibility is 50% (\$250).
 The cost of an item with the customer logo and two different vendor logos would be split three ways.

Co-op dollars will only be paid in the form of a material credit to your account. Unused dollars do not carry over to the following year.



Order by assigned part numbers.

FLTA-ENTS



Entry Door Counter Display:

Jamb cover, Brickmould, 3-1/2" casing with J-Mould. Outswing Clad on the inside of jamb. Plastic brochure pocket with 25 brochures and a backing card giving features and benefits of our clad. Color card.

FLTA-GDFS



Pro-Series & Builders Series Garage Door Frame Display:

Display has a backer card listing the features and benefits. Pro-Series also has the 3-1/2" casing with the J-Mould. The display has open corner showing how the frame is assembled. Color card & 25 pack of brochures.

FLTA-PRO 12" KD



Pro Series Knock Down Sample:

Includes 12" header, verticals with 2 gussets. Assembly insulation kit. Demonstrates ease of assembly.

FLTA-12S



12" Hand Sample:

Shows jamb cover, Crownline, Brickmould, 3-1/2" casing with J-Mould, Color card.

FrontLine® Color Deck



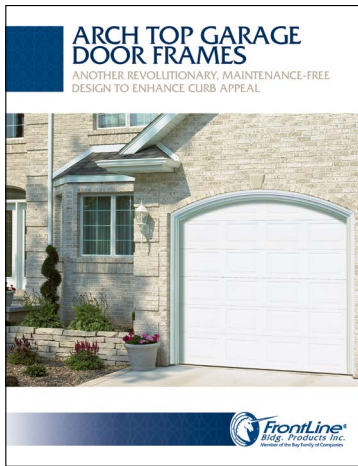

Arch Top Garage Door Frame Brochure

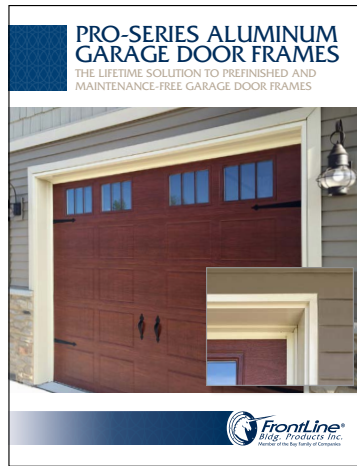

Pro-Series All-Aluminum Garage Door Frame Brochure

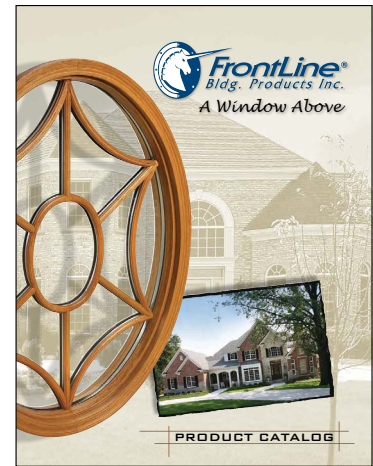

Window Catalog



Tru-Loc™ Installation Anchors Brochure



Pre-Clad Door Frames Brochure

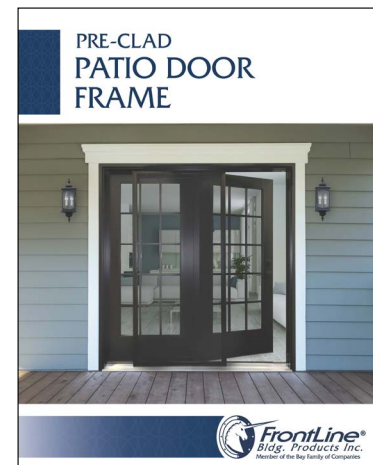

Pre-Clad Patio Door Frame Brochure



Entry Door System Brochure

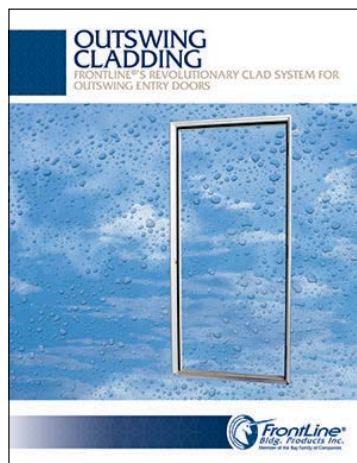

Outswing Cladding Brochure

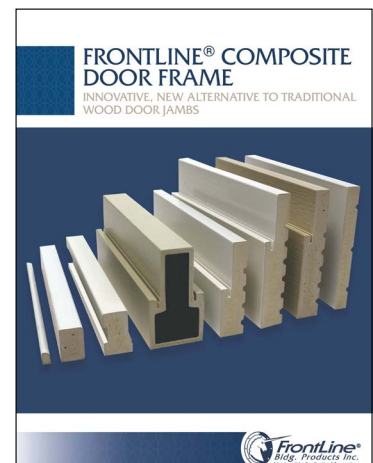

FrontLine Composite Door Frame Brochure



BayShield™ Commercial Outswing Door Brochure

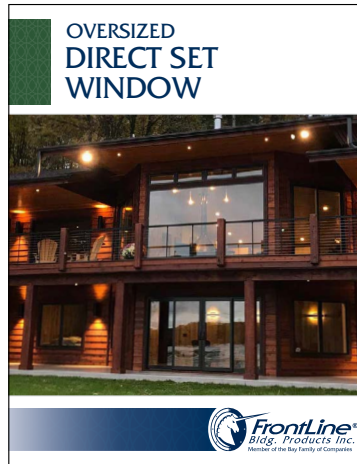

Oversized Direct Set Window Brochure

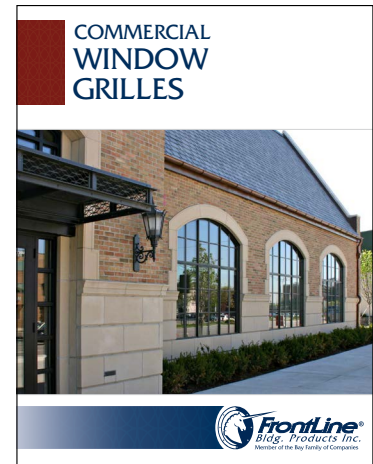

Commercial Grille Brochure

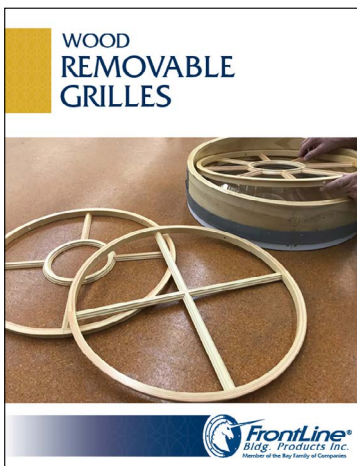

Wood Removable Grilles Brochure



Pro-Series All Aluminum Garage Door Frame Trifold

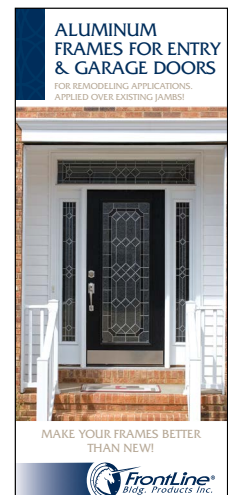

Aluminum Frames for Remodeling Applications on Entry & Garage Doors Trifold



Entry Door System Trifold



Stock Color Chart

Limited Lifetime Warranty

Aluminum Cladding and All Aluminum Garage Door Frame

Door Frame

FrontLine® Bldg. Products Inc. warrants to the original residential homeowner, the aluminum entry door cladding and / or the all-aluminum garage door frame for as long as he/she owns the home in which the aluminum cladding or all-aluminum garage door frame is installed. FrontLine® Bldg. Products Inc. warrants the product to be free from manufacturing defects in materials and workmanship. This warranty is applicable to the aluminum entry door cladding material only and the all-aluminum garage door frame material only. This warranty is not intended to include the substrate to which the aluminum entry door cladding is applied, nor to any portion of the framework that the entry door or all-aluminum garage door frame is applied. Warranty of the entry door, the entry door wood frame, sill, side lites, transom, etc. is covered by the manufacturer of those products. This warranty applies to the original homeowner only, and owner occupied homes only. Home owner must supply proof of purchase. If the product is determined to be defective, FrontLine® Bldg. Products Inc. will, at its own option, offer one of the following:

- Repair the defective product
- Replace the defective product
- Refund purchase price
- If you chose to replace the product, FrontLine® Bldg. Products Inc. will not be responsible for any installation of the replacement product or removal of the effective product.

Limitations:

Conditions and applications that FrontLine® Bldg. Products Inc. is not responsible for and over which they do not have control:

- Improper installation
- Misuse
- Fire
- Corrosion or any finish failures of aluminum cladding or all-aluminum garage door frame components due to environmental conditions such as salt spray, acid rain or other corrosive substances.
- Applications in seacoast areas due to corrosion.
- Conditions or use exceeding design standards.
- Any normal wear or discoloration of finishes.
- Natural disasters (flood, hurricane, typhoon, tornado, or other natural disaster not specifically listed here).

FrontLine® Bldg. Products Inc. is not liable for consequential damage or the recovery of other direct or indirect costs (shipping, handling, installation, removal, reinstallation, finish painting, etc.)

THIS WARRANTY IS IN LIEU OF ALL OTHER WARRANTIES, EXPRESSED OR IMPLIED. (SOME STATES DO NOT ALLOW LIMITATION ON WARRANTED PARTS, SO THIS LIMITATION MAY NOT APPLY TO YOU). THIS WARRANTY SHALL BE VOID IF DAMAGE WAS DUE TO IMPROPER INSTALLATION, MAINTENANCE, OR USE. THIS WARRANTY GIVES YOU SPECIFIC RIGHTS, AND YOU MAY ALSO HAVE RIGHTS, WHICH VARY, FROM STATE TO STATE.

All claims under this warranty shall be addressed in writing to:

FRONTLINE® BLDG. PRODUCTS INC.
P.O. BOX 9229
GREEN BAY, WI 54308-9229



Brickmould Replacement Instructions

In case of damage to clad product, please follow the following recommendations for removal and reinstallation of brickmould trim extrusion.

- 1) Drill 3/8" holes in Brickmould. Hole #1 located at 1st ridge. This hole must also go through the nail fin behind the Brickmould.

Hole #2, 1/8" from inside edge of Brickmould. Drill this hole only through outer layer of Brickmould extrusion.

Holes will allow insertion of saw blade.

- 2) Insert tip of metal cutting reciprocating saw blade into hole #1 and cut through aluminum brickmould and nail fin, along entire length of damaged piece, following ridge. Be careful not to damage undamaged aluminum at miters.

Using a #2 phillips screwdriver, remove miter screws from top of side brickmould. If caulked, you may need to cut away and clean for new caulk.

Now you can remove the part of the brickmould that has been cut free.

Insert blade into hole #2 and cut damaged brickmould along entire length. Once again being careful not to damage miters or frame cover beneath.

You can now remove the remainder of the damaged piece of brickmould.

- 3) You are now ready to fit and secure your new brickmould extrusion. By using the damaged pieces, check measurements of replacement piece. Once measured and trimmed if necessary. The new extrusion can be snapped into place using a rubber mallet. Replace the miter screws and caulk outside edge.

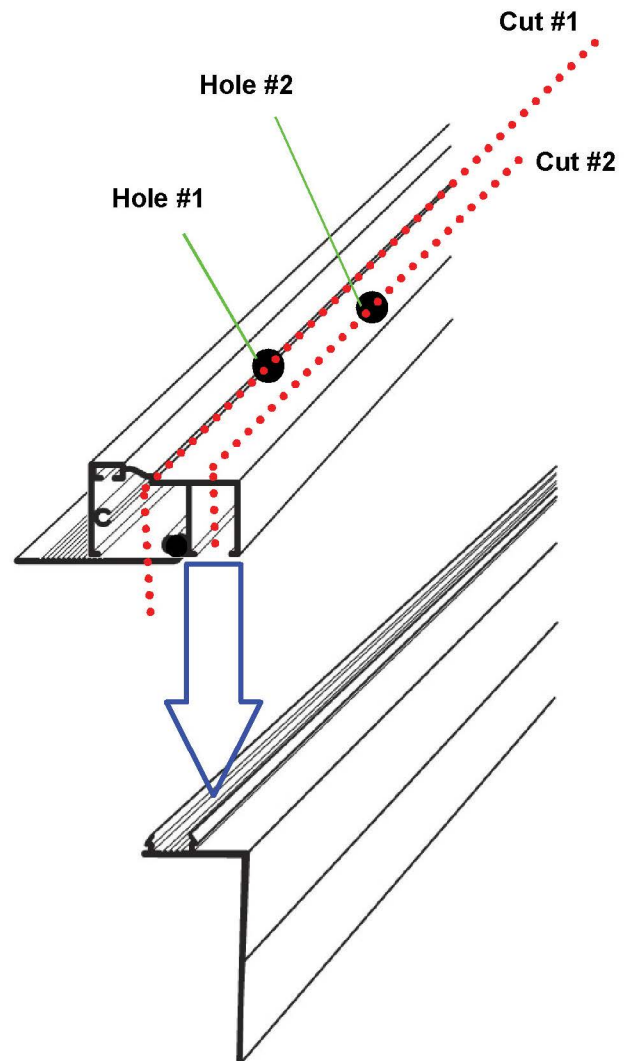

TAB 12: SPEC SHEETS
(after page 72)

920-406-4600 Fax: 920-406-4646

Customer _____

Door Brand _____

Classic Clad h

Original Clad h

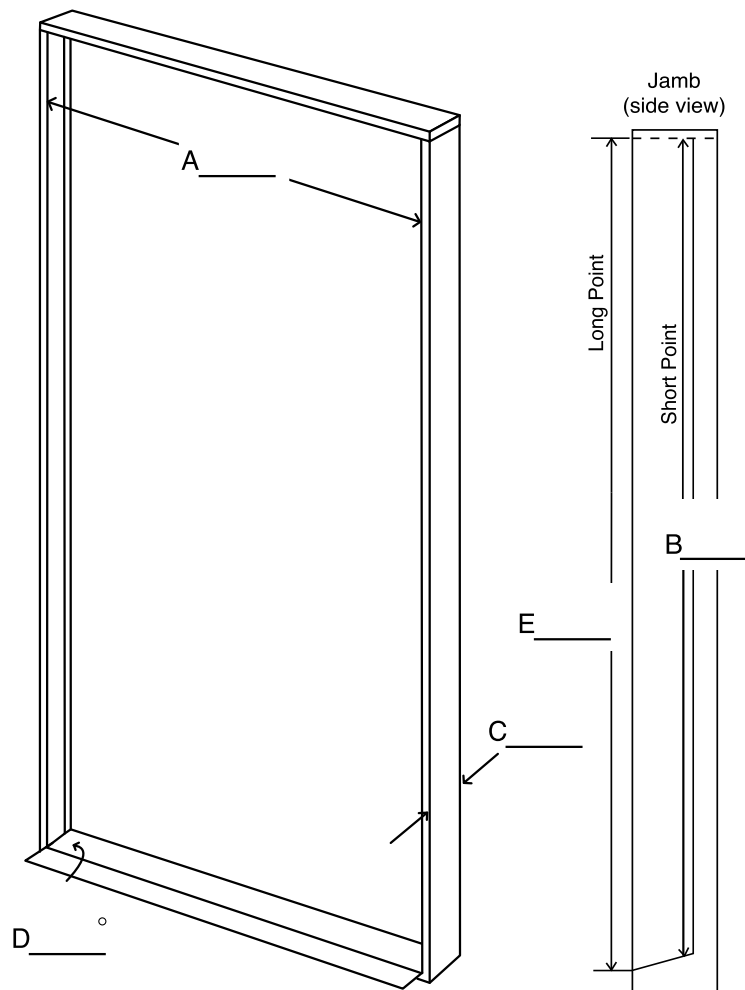

- A. Frame Opening Width
- B. Frame Opening Height (Short Point)
- C. Jamb Depth
- D. Sill Angle
- E. Long Point

Customer _____

Door Brand _____

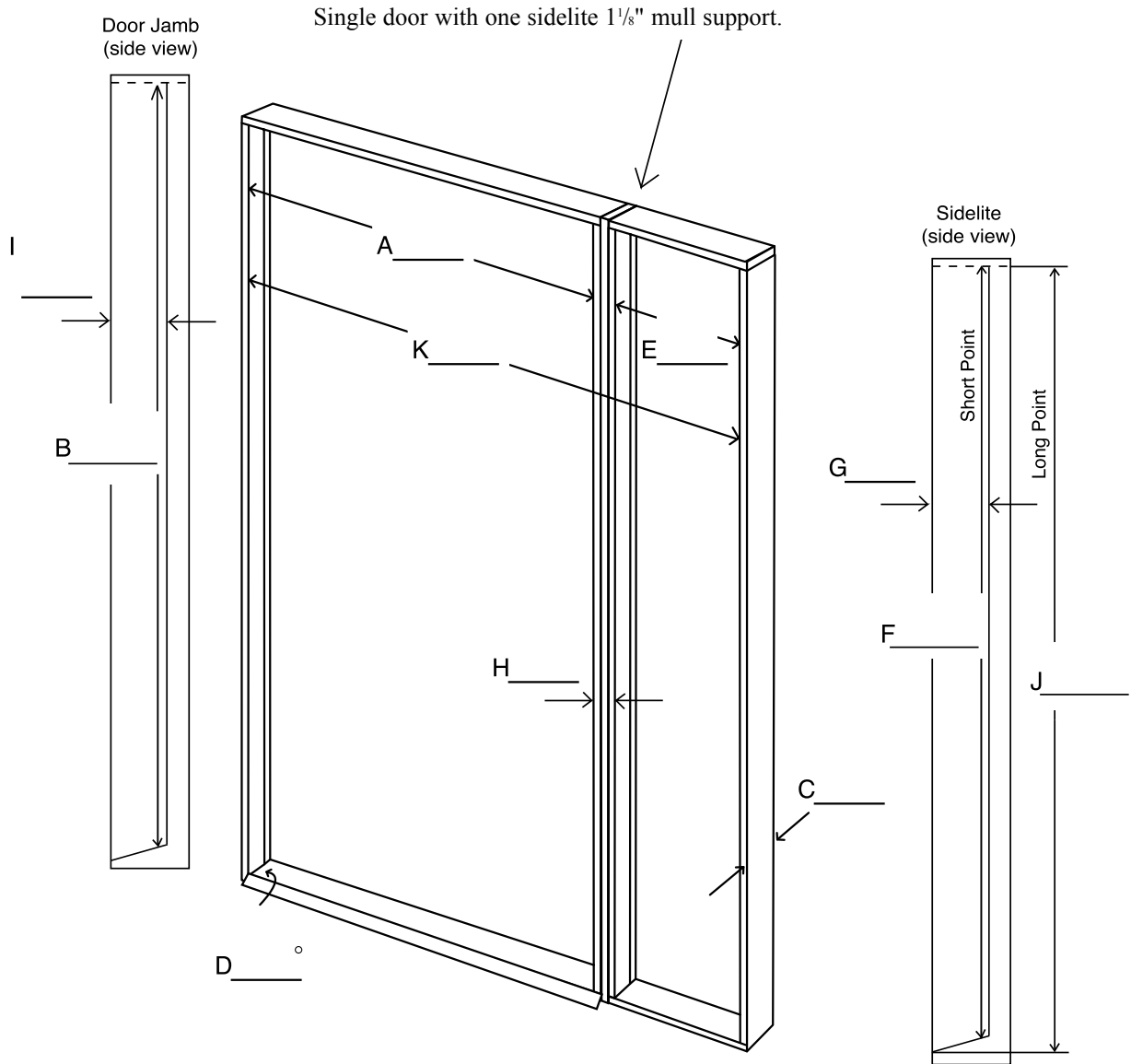

- | | |
|----------------------------|-------------------------|
| A. Frame Opening Width | G. Sidelite Jamb Depth |
| B. Frame Opening Height | H. Mull Width |
| C. Jamb Depth | I. Jamb Depth to Dado |
| D. Sill Angle | J. Long Point |
| E. Sidelite Opening Width | K. Overall Inside Width |
| F. Sidelite Opening Height | |

Customer _____

Door Brand _____

Single door with two sidelites 1 1/8" mull support.

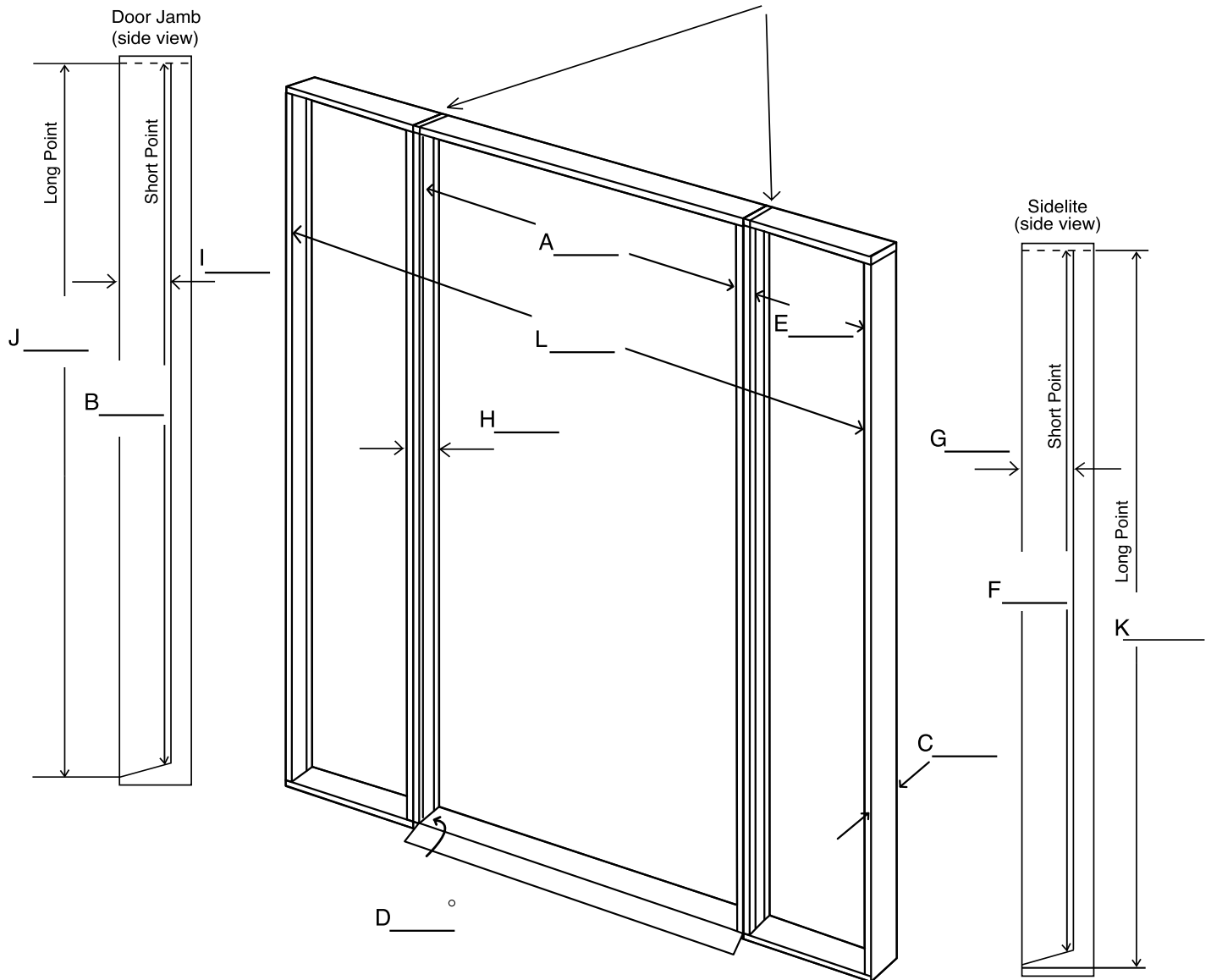

- | | |
|----------------------------|-------------------------|
| A. Frame Opening Width | G. Sidelite Jamb Depth |
| B. Frame Opening Height | H. Mull Width |
| C. Jamb Depth | I. Jamb Depth to Dado |
| D. Sill Angle | J. Long Point |
| E. Sidelite Opening Width | K. Long Point |
| F. Sidelite Opening Height | L. Overall Inside Width |

Customer _____

Door Brand _____

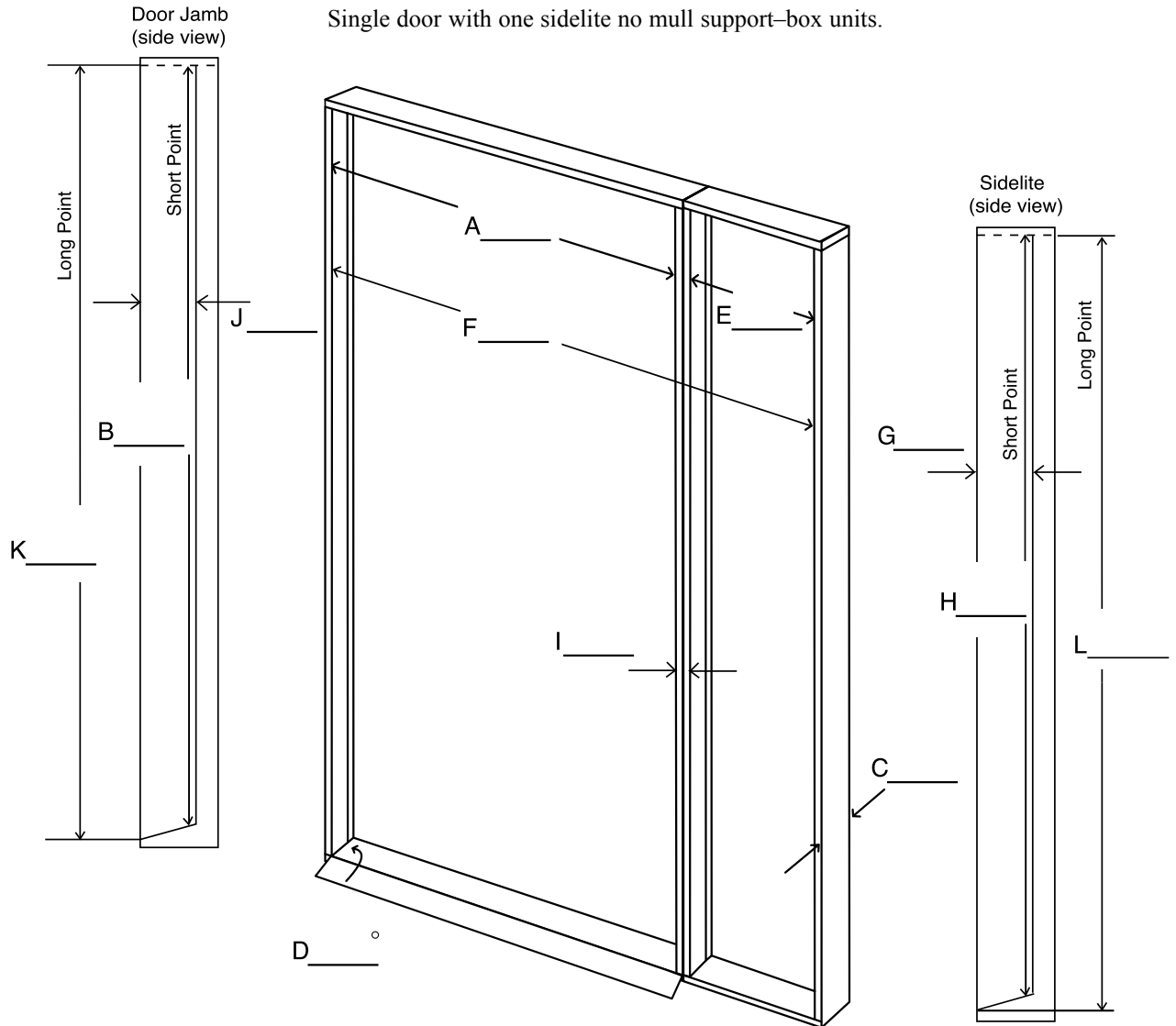

- A. Frame Opening Width
- B. Frame Opening Height (Short Point)
- C. Jamb Depth
- D. Sill Angle
- E. Sidelite Opening Width
- F. Overall Inside Width

- G. Sidelite Jamb Depth
- H. Jamb Height (Short Point)
- I. Mull Width
- J. Jamb Depth to Dado
- K. Long Point
- L. Long Point



Customer _____

Door Brand _____

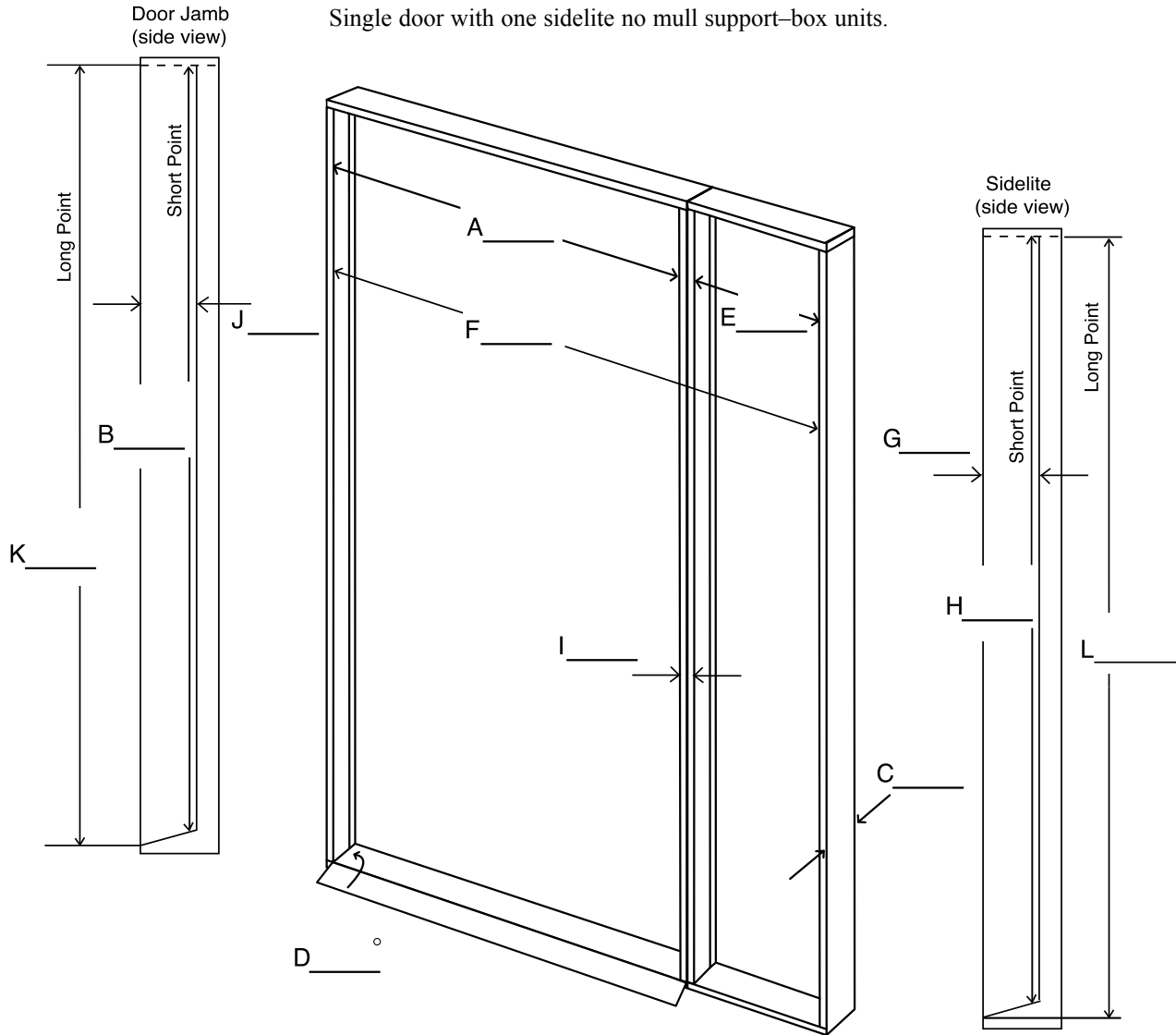

- | | |
|---------------------------------------|------------------------------|
| A. Frame Opening Width | G. Sidelite Jamb Depth |
| B. Frame Opening Height (Short Point) | H. Jamb Height (Short Point) |
| C. Jamb Depth | I. Mull Width |
| D. Sill Angle | J. Jamb Depth to Dado |
| E. Sidelite Opening Width | K. Long Point |
| F. Overall Inside Width | L. Long Point |



Customer _____

Door Brand _____

Single door with two sidelites no mull support-box units.

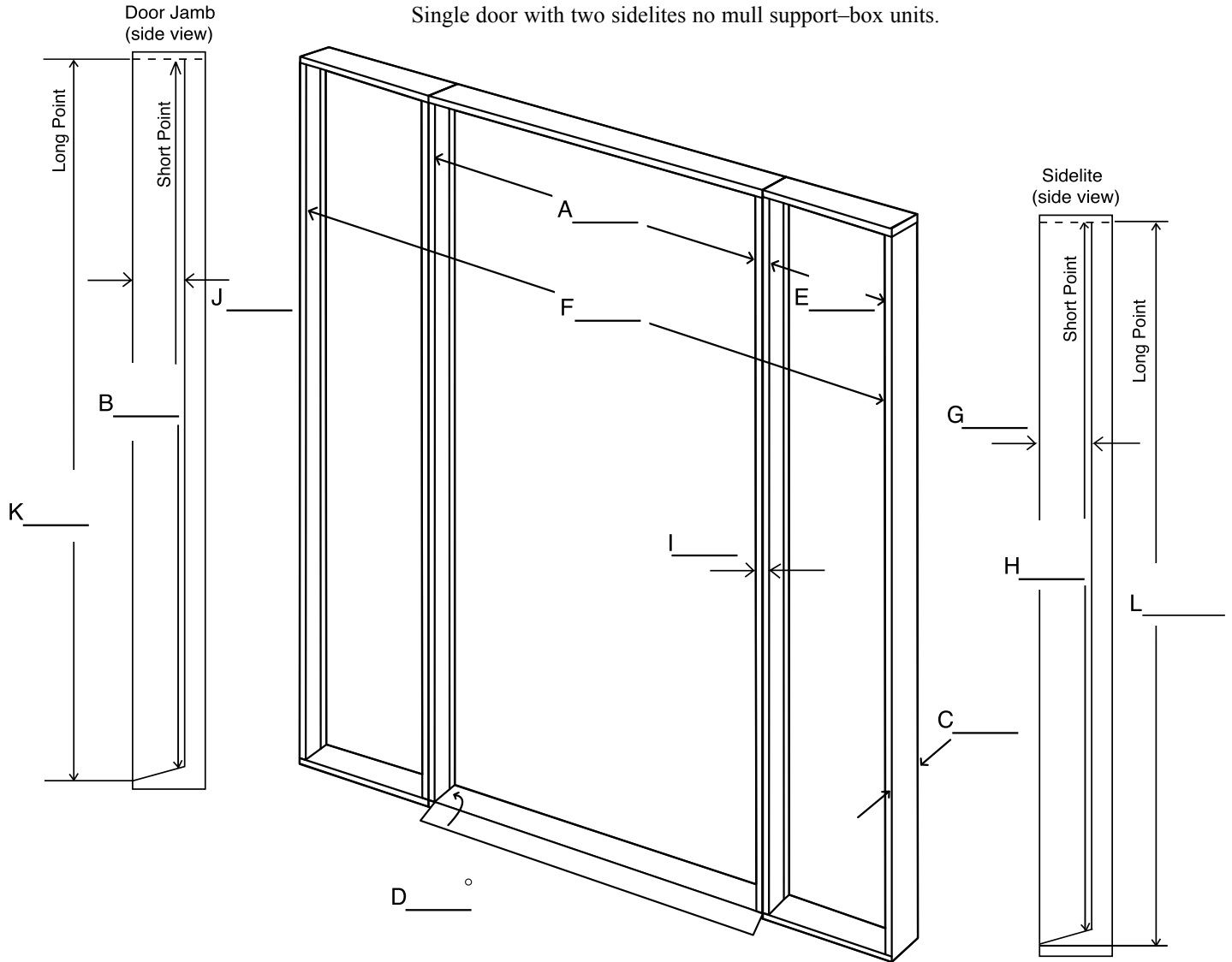

- | | |
|--|----------------------------------|
| A. Frame Opening Width | G. Sidelite Jamb Depth |
| B. Frame Opening Height (Short Point) | H. Sidelite Height (Short Point) |
| C. Jamb Depth | I. Mull Post Width |
| D. Sill Angle | J. Jamb Depth to Dado |
| E. Sidelite Opening Width | K. Long Point |
| F. Inside Overall Width (Including Sidelite) | L. Long Point |



Customer _____

Door Brand _____

Single door with two sidelites continuous head & sill.

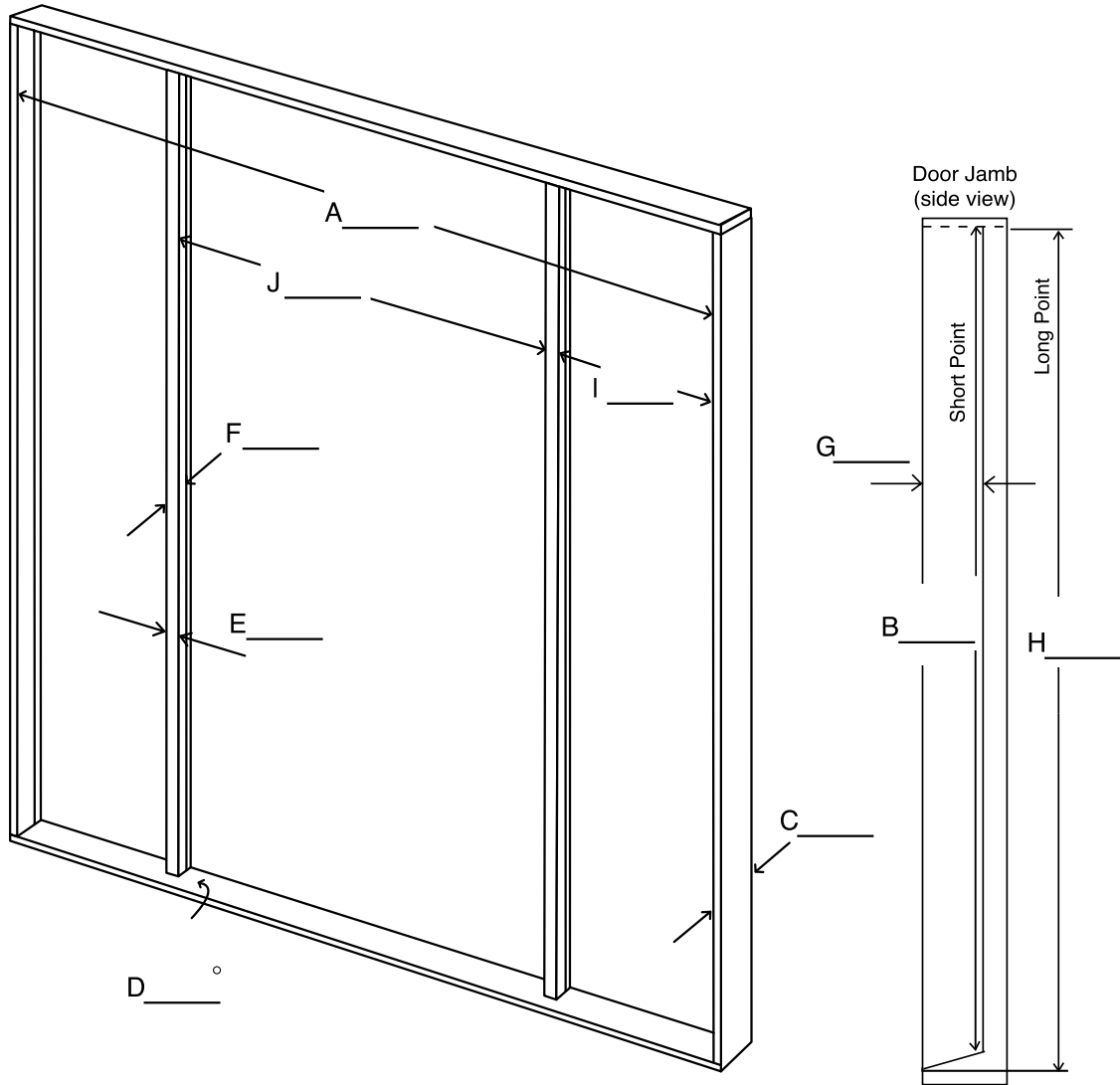

- | | |
|---------------------------------------|----------------------------|
| A. Frame Opening Overall Width | E. Mull Post Width |
| B. Frame Opening Height (Short Point) | F. Mull Post Depth to Dado |
| C. Jamb Depth | G. Jamb Depth to Dado |
| D. Sill Angle | H. Long Point |
| | I. Sidelite Width |
| | J. Frame Opening Width |

Customer _____

Door Brand _____

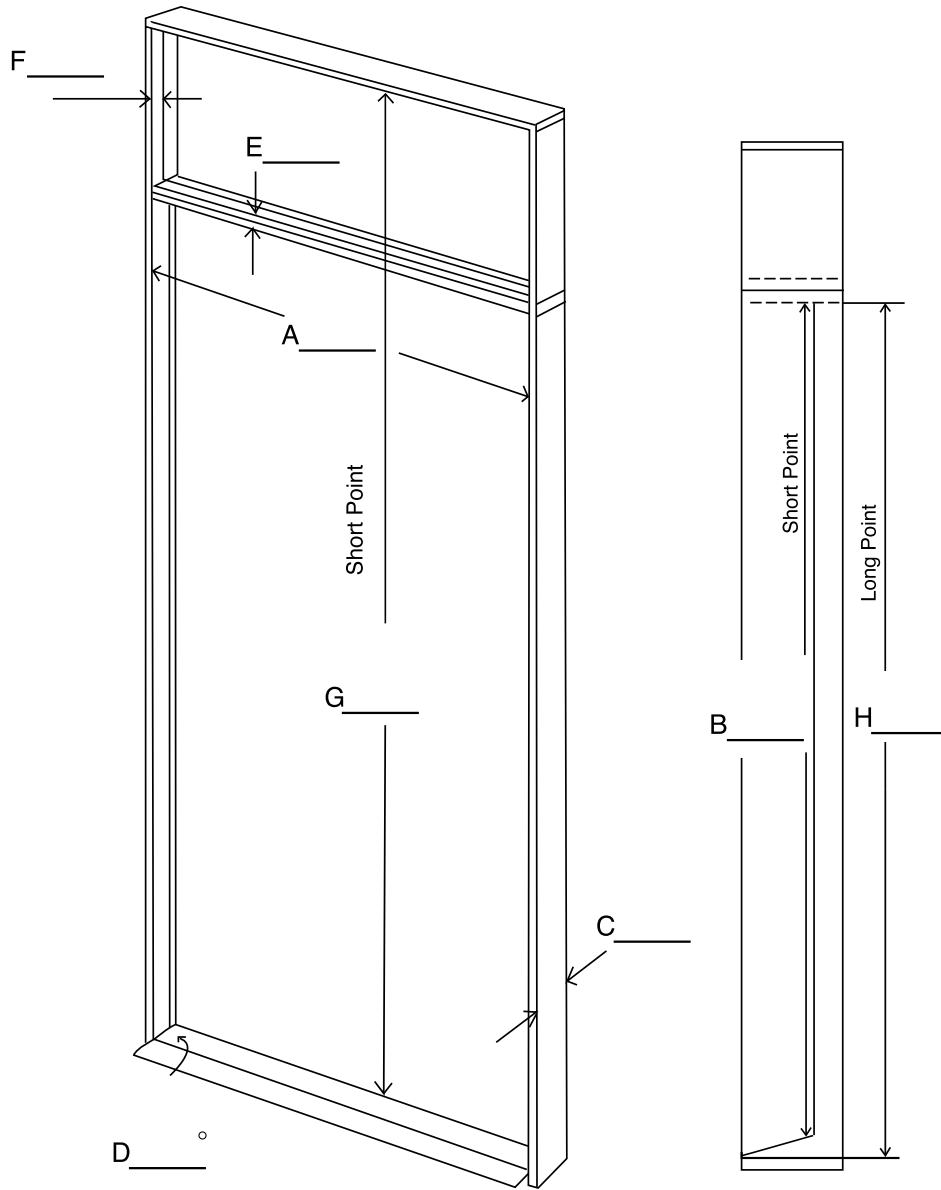

- A. Frame Opening Width
- B. Frame Opening Height (Short Point)
- C. Jamb Depth
- D. Sill Angle
- E. Mull Width
- F. Transom Depth to Glass
- G. Total Height for Verticals (Short Point)
- H. Long Point

Customer _____

Door Brand _____

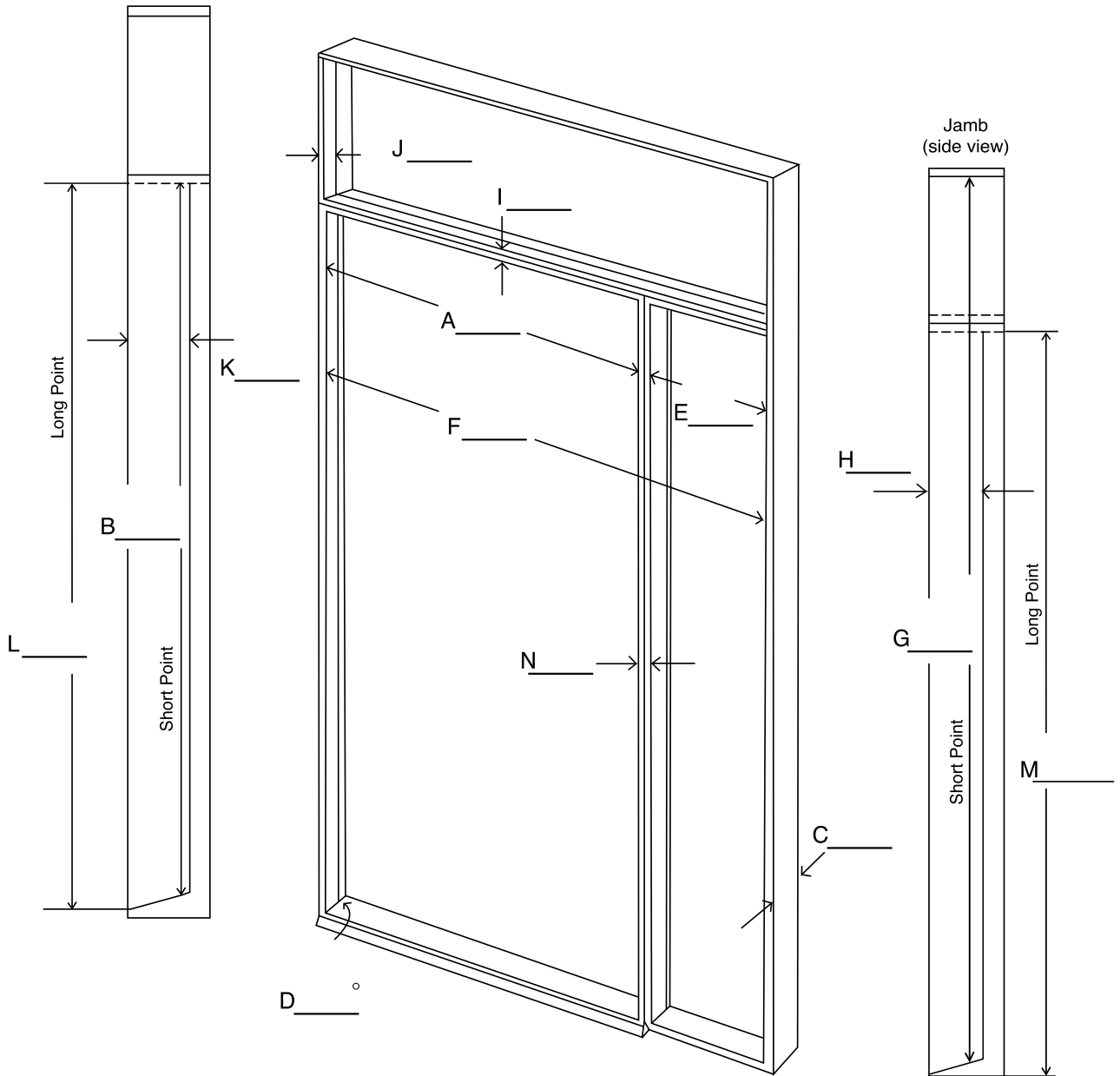

- | | |
|--|---------------------------------|
| A. Frame Opening Width | H. Mull Depth to Sidelite |
| B. Frame Opening Height (Short Point) | I. Header Thickness and Transom |
| C. Jamb Depth | J. Jamb Depth to Glass |
| D. Sill Angle | K. Jamb Depth to Dado |
| E. Sidelite Opening Width | L. Long Point |
| F. Inside Frame Overall Width (Including Sidelite) | M. Long Point |
| G. Jamb Height Including Transom (Short Point) | N. Mull Width |



Customer _____

Door Brand _____

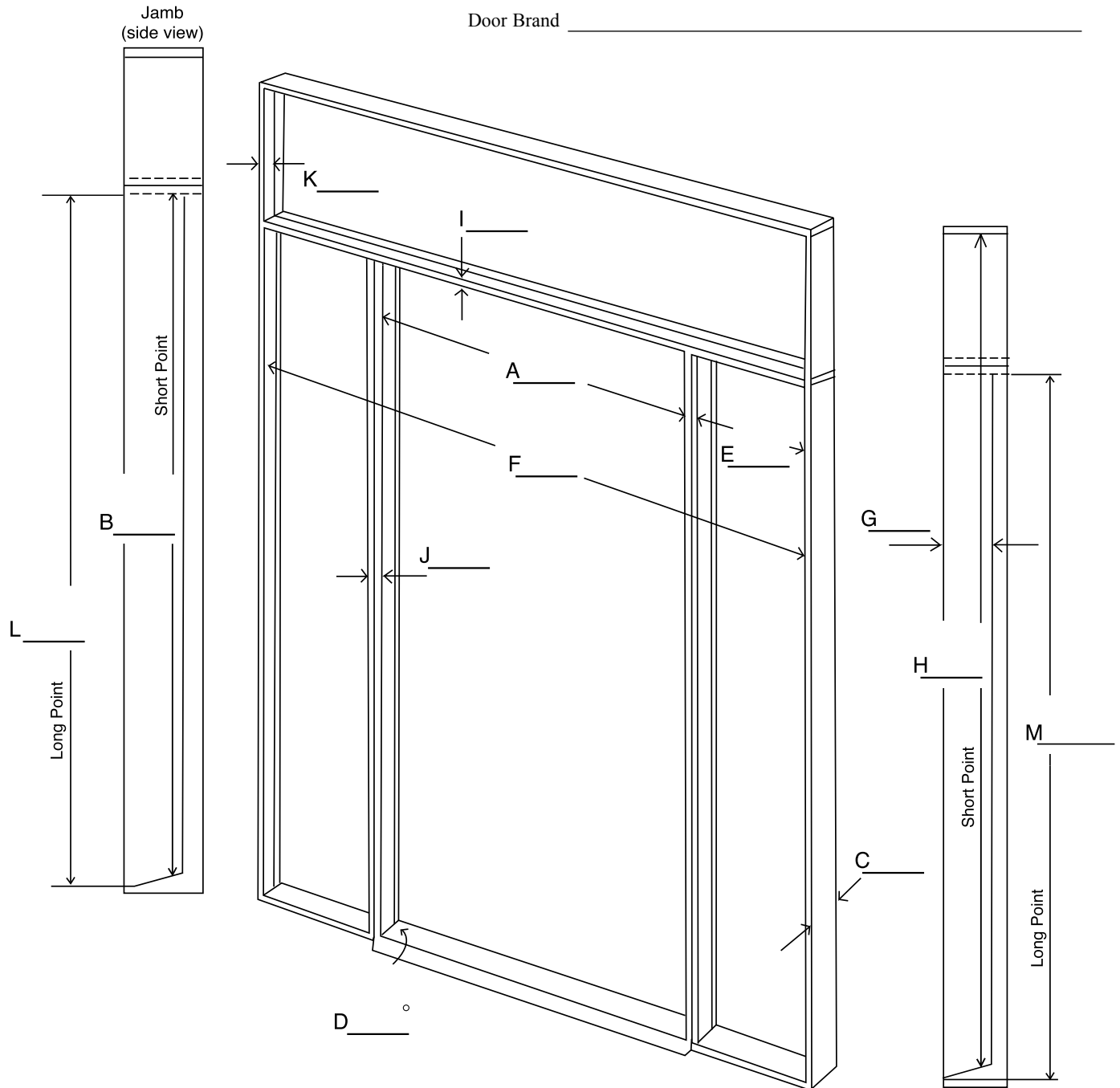

- | | |
|--|--|
| A. Door Frame Opening Width | G. Side Jamb Depth to Sidelite |
| B. Frame Opening Height (Short Point) | H. Jamb Height Including Transom |
| C. Jamb Depth | Short point sill angle to inside top of head |
| D. Sill Angle | I. Thickness of Header |
| E. Sidelite Opening Width | J. Thickness of Mull |
| F. Inside Frame Overall Width (Including Sidelite) | K. Jamb Depth to Glass |
| | L. Long Point |
| | M. Long Point |

Outswing

Phone: 920-393-1340 Fax: 920-227-9590

Customer _____

Door Brand _____

(Hinge Location)
Outside View

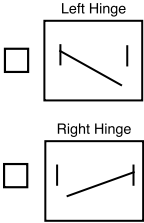

All of the following side jamb measurements are from inside of header down.

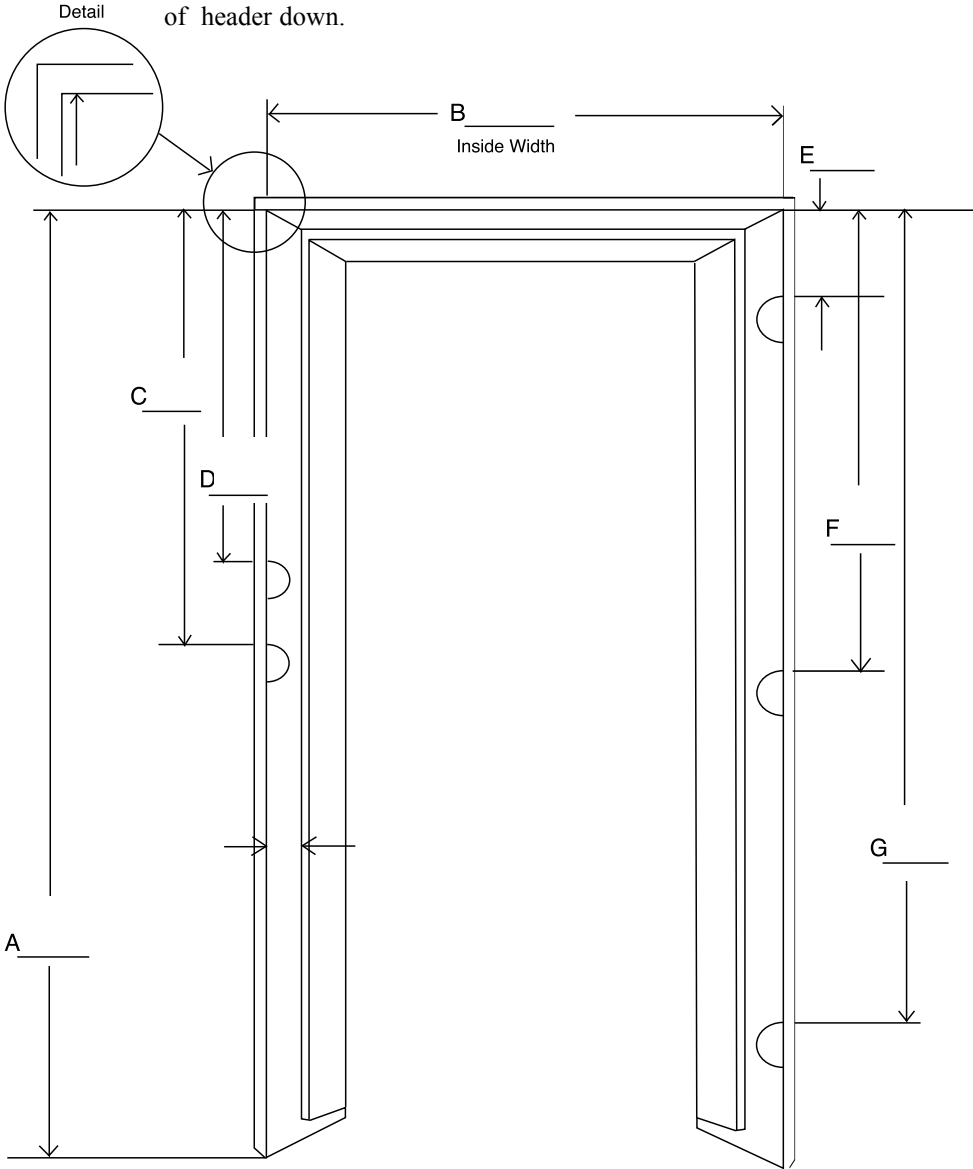

- A. Finished Opening Height
 - B. Finished Opening Width
 - C. Location Latch
 - D. Location of Deadbolt (specify size and type)
 - E. Location of 1st Hinge
 - F. Location of 2nd Hinge
 - G. Location of 3rd Hinge
 - H. Non-Standard
- Special Note: _____



(after page 83)

TAB 13: BAYSHIELD COMMERCIAL DOOR

INSERT COMMERCIAL DOOR BROCHURE AFTER TAB

BAYSHIELD® COMMERCIAL OUTSWING DOOR



BayShield® Commercial Outswing Door

FrontLine Bldg. Products Inc. has been providing manufacturing support and solutions for the window and door industry since 1978. Our experience helps ensure an exceptional product, engineered to perfection. Through teamwork we attain total customer satisfaction and consistently exceed our customers' expectations.



Interior Features

- Wood species pine standard. Additional wood species available.
- Primed or stain/paint grade ready.

Exterior Features

- **Aluminum Clad Exterior**

Available with heavy-duty, durable maintenance-free extruded aluminum cladding.

Bottom rail cladding 1/8" thick (7 gauge), remaining rail & stile components 1/16" (14 gauge) thick extruded aluminum cladding.

- **Wood Exterior**

Multiple wood species available.

Primed or stain/paint grade ready.



Standard Sizes:

- Single Door Widths: 2-6, 3-0, 3-6
- Double Door Widths: 5-0, 6-0, 7-0
- Door Heights: 6-8, 7-0, 8-0
- Custom sizes available.

Performance:

- NFRC Rated
- Hallmark Certified
- Impact Certified/Florida HVHZ Windzone 4 Certified

Frame Construction

- 1-1/4" thick engineered core wood frame.
- Heavy-duty extruded aluminum exterior frame cladding (15 gauge).
- Integral rigid aluminum nailing fin.
- Frame cladding corners silicone injected and mechanically fastened.

Slab Construction

- 1-3/4" thick stiles and rails with engineered wood core, solid wood edge band and Poly-Bak™ lined faced veneers.
- Both hinge and lock stiles include engineered LVL wood core.
- All wood parts made from kiln-dried preservative treated wood.
- Stiles and rails are joined using 5/8" diameter glued wood dowels.
- Flexible finned cap system provided at door head.



Sill Options:

- ADA Sill
- ADA Sill with thermal break
- Bumper Sill
- Also available without sill



Panel Options

Flat Panel Design



Raised Panel Design



Hinges

- Each door slab hung with four solid brass commercial ball bearing hinges (4-1/2" x 4-1/2").
- Hinge color/finish options are available.
- For added strength and reliability, each hinge is fastened to the jamb using two machine screws and threaded "T" nuts.
- "T" nuts provided to prevent screws from stripping.



Paint & Stain Finish Options;

- **Interior:**
 - Unfinished or painted/stained to your specifications.
- **Exterior:**
 - Wood: unfinished, primed or painted/stained to your specifications.
 - Clad: AAMA 2605 paint finish standard. AAMA 2603 & 2604 finishes also available. Wide selection of standard colors & custom color matching available.



Other Options:

- Grilles: Simulated Divided Lite (SDL), grilles in airspace (GIA), wood removable.
- Glass: Insulated glass, decorative glass, Impact Glass.
- Hardware prep machined to your specifications.
- Transom and sidelites available.

Interior Features



WEATHER-STRIPPING

E-Lon™ weatherstripping provided on head & side jambs.

INTERIOR FRAME/JAMB:

1-1/4" edge banded LVL engineered core frame. Standard jamb depth of 4-9/16". Optional jamb depths available.

SILL:

Standard aluminum ADA, ADA sill with thermal break & bumper sill options available. Multiple sill finishes available.

PANEL DESIGNS

Flat & raised panel designs available.

GLAZING BEAD

Square or Ovolo glazing bead available.

WOOD SPECIES

Standard Pine with multiple wood species available.

RAILS & STILES

1-3/4" thick stiles and rails with engineered wood core, solid wood edge band and Poly-Bak™ lined face veneers. Both hinge & lock stiles include an engineered LVL wood core.

Exterior Features

PANEL DESIGNS

Flat & raised panel designs available. Aluminum clad and painted, exterior grade, MDF panel designs available.

EXTERIOR CLADDING

Bottom rail cladding provided with durable 1/8" thickness. All other rails & stiles provided with 1/16" thickness. All cladding seams are overlapped and siliconed to ensure a weather-tight seal. All wood exterior panel options available. Multiple wood species available.

PAINT FINISHES

Baked on enamel paint finish AAMA 2605 standard. AAMA 2603 & 2604 paint finishes also available.

FRAME EXTERIOR

Extruded aluminum frame (15 gauge) with integral rigid aluminum nailing fin. Frame corners/miters silicone injected and mechanically fastened. All wood frame exterior option available. Multiple wood species available.

HINGES

Each door panel comes standard with (Qty 4) 4-1/2"x4-1/2" solid brass ball bearings commercial grade hinges. Each hinge is fastened to the jamb using two machine screws and threaded "T" nuts. Multiple finish options available.

DOOR SWEEP

Replaceable flexible door sweep provided at door sill.



LIGHT COMMERCIAL OUTSWING DOOR SIZE TABLES

ALUMINUM CLAD WOOD - FULL VIEW

| SIZE | 2/6 | 3/0 | 3/6 | 5/0 | 6/0 | 7/0 |
|------|-----------|-----------|-----------|-------------|-------------|-------------|
| RO | 2'-8 5/8" | 3'-2 5/8" | 3'-8 5/8" | 5'-2 11/16" | 6'-2 11/16" | 7'-2 11/16" |
| FS | 2'-7 5/8" | 3'-1 5/8" | 3'-7 5/8" | 5'-1 11/16" | 6'-1 11/16" | 7'-1 11/16" |
| GS | 1'-8 5/8" | 2'-2 5/8" | 2'-8 5/8" | 1'-8 5/8" | 2'-2 5/8" | 2'-8 5/8" |
| 6/8 | | | | | | |
| | 2668 | 3068 | 3668 | 5068 | 6068 | 7068 |
| 7/0 | | | | | | |
| | 2670 | 3070 | 3670 | 5070 | 6070 | 7070 |
| 8/0 | | | | | | |
| | 2680 | 3080 | 3680 | 5080 | 6080 | 7080 |

OPERATION IS VIEWED FROM EXTERIOR. HINGE SIDE MUST BE SPECIFIED WHEN ORDERING A SINGLE WIDE DOOR.

OPTIONAL STYLES

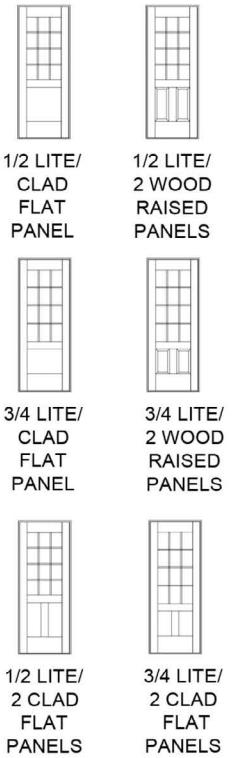

Custom panel styles available upon request

ALUMINUM CLAD WOOD - SIDELITE

| SIZE | 1/0 | 1/4 | 1/6 | 1/8 |
|------|-----------|-----------|-----------|------------|
| RO | 1'-2 5/8" | 1'-6 5/8" | 1'-8 5/8" | 1'-10 5/8" |
| FS | 1'-1 5/8" | 1'-5 5/8" | 1'-7 5/8" | 1'-9 5/8" |
| GS | 0'-8 5/8" | 1'-0 5/8" | 1'-2 5/8" | 1'-4 5/8" |
| 6/8 | | | | |
| | 1068 | 1468 | 1668 | 1868 |
| 7/0 | | | | |
| | 1070 | 1470 | 1670 | 1870 |
| 8/0 | | | | |
| | 1080 | 1480 | 1680 | 1880 |

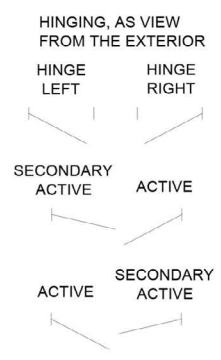
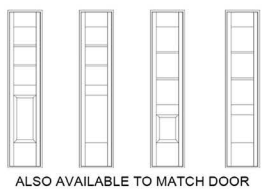

NOT TO SCALE
 SIZES GIVEN ARE FOR UNITS WITH RIM DEVICE TYPE HARDWARE. SUBTRACT 3/16" FROM WIDTH OF FRAME FOR DOUBLE DOOR UNITS WITH MULTI-POINT HARDWARE. ADDITIONAL SIZES ARE AVAILABLE UPON REQUEST (2068 TO 3680, 4068 TO 7080)
 SIDELITE | ADDITIONAL SIZES MAY BE AVAILABLE UPON REQUEST (1068 TO 1880)
 RO - OPENING, FS - FRAME SIZE, GS - GLASS SIZE

PROPRIETARY NOTICE: THE INFORMATION CONTAINED IS THE SOLE PROPERTY OF FRONTLINE BLDG. PRODUCTS INC. ANY REPRODUCTION IN PART OR AS A WHOLE WITHOUT THE WRITTEN PERMISSION OF FRONTLINE BLDG. PRODUCTS INC. IS PROHIBITED.

LIGHT COMMERCIAL OUTSWING DOOR SIZE TABLES

ALUMINUM CLAD WOOD - TRANSMOM

| SIZE | 2/6 | 3/0 | 3/6 | 5/0 | 6/0 | 7/0 |
|------|---|---|---|---|---|---|
| *RO | 2'-8 ⁵ / ₁₆ " | 3'-2 ⁵ / ₁₆ " | 3'-8 ⁵ / ₁₆ " | 5'-2 ¹ / ₁₆ " | 6'-2 ¹ / ₁₆ " | 7'-2 ¹ / ₁₆ " |
| *FS | 2'-7 ⁵ / ₈ " | 3'-1 ⁵ / ₈ " | 3'-7 ⁵ / ₈ " | 5'-1 ¹ / ₁₆ " | 6'-1 ¹ / ₁₆ " | 7'-1 ¹ / ₁₆ " |
| *GS | 2'-2 ³ / ₄ " | 2'-8 ³ / ₄ " | 3'-2 ³ / ₄ " | 2'-2 ³ / ₄ " | 2'-8 ³ / ₄ " | 3'-2 ³ / ₄ " |
| 1/0 | 1'-0 ¹ / ₂ " 1'-0" | 1'-0 ¹ / ₂ " 1'-0" | 1'-0 ¹ / ₂ " 1'-0" | 1'-0 ¹ / ₂ " 1'-0" | 1'-0 ¹ / ₂ " 1'-0" | 1'-0 ¹ / ₂ " 1'-0" |
| 1/2 | 1'-2 ¹ / ₂ " 1'-2" | 1'-2 ¹ / ₂ " 1'-2" | 1'-2 ¹ / ₂ " 1'-2" | 1'-2 ¹ / ₂ " 1'-2" | 1'-2 ¹ / ₂ " 1'-2" | 1'-2 ¹ / ₂ " 1'-2" |
| 1/6 | 1'-6 ¹ / ₂ " 1'-6" | 1'-6 ¹ / ₂ " 1'-6" | 1'-6 ¹ / ₂ " 1'-6" | 1'-6 ¹ / ₂ " 1'-6" | 1'-6 ¹ / ₂ " 1'-6" | 1'-6 ¹ / ₂ " 1'-6" |
| 1/8 | 1'-8 ¹ / ₂ " 1'-8" | 1'-8 ¹ / ₂ " 1'-8" | 1'-8 ¹ / ₂ " 1'-8" | 1'-8 ¹ / ₂ " 1'-8" | 1'-8 ¹ / ₂ " 1'-8" | 1'-8 ¹ / ₂ " 1'-8" |
| | 2610 | 3010 | 3610 | 5010 | 6010 | 7010 |
| | 2612 | 3012 | 3612 | 5012 | 6012 | 7012 |
| | 2616 | 3016 | 3616 | 5016 | 6016 | 7016 |
| | 2618 | 3018 | 3618 | 5018 | 6018 | 7018 |
| 1/0 | *GS 1'-8 ¹ / ₄ " 1'-0 ¹ / ₂ " 1'-0" | 2'-2 ¹ / ₄ " 1'-0 ¹ / ₂ " 1'-0" | 2'-8 ¹ / ₄ " 1'-0 ¹ / ₂ " 1'-0" | 1'-8 ¹ / ₄ " 1'-0 ¹ / ₂ " 1'-0" | 2'-2 ¹ / ₄ " 1'-0 ¹ / ₂ " 1'-0" | 2'-8 ¹ / ₄ " 1'-0 ¹ / ₂ " 1'-0" |
| 1/2 | 1'-2 ¹ / ₂ " 1'-2" | 1'-2 ¹ / ₂ " 1'-2" | 1'-2 ¹ / ₂ " 1'-2" | 1'-2 ¹ / ₂ " 1'-2" | 1'-2 ¹ / ₂ " 1'-2" | 1'-2 ¹ / ₂ " 1'-2" |
| 1/6 | 1'-6 ¹ / ₂ " 1'-6" | 1'-6 ¹ / ₂ " 1'-6" | 1'-6 ¹ / ₂ " 1'-6" | 1'-6 ¹ / ₂ " 1'-6" | 1'-6 ¹ / ₂ " 1'-6" | 1'-6 ¹ / ₂ " 1'-6" |
| 1/8 | 1'-8 ¹ / ₂ " 1'-8" | 1'-8 ¹ / ₂ " 1'-8" | 1'-8 ¹ / ₂ " 1'-8" | 1'-8 ¹ / ₂ " 1'-8" | 1'-8 ¹ / ₂ " 1'-8" | 1'-8 ¹ / ₂ " 1'-8" |
| | 2610 | 3010 | 3610 | 5010 | 6010 | 7010 |
| | 2612 | 3012 | 3612 | 5012 | 6012 | 7012 |
| | 2616 | 3016 | 3616 | 5016 | 6016 | 7016 |
| | 2618 | 3018 | 3618 | 5018 | 6018 | 7018 |

NARROW
STILE

WIDE
STILE

| SIZE | 5/0 | 6/0 | 7/0 | 1/0 | 1/4 | 1/6 | 1/8 |
|------|--|--|--|---|---|---|---|
| *RO | 5'-2 ¹ / ₁₆ " | 6'-2 ¹ / ₁₆ " | 7'-2 ¹ / ₁₆ " | 1'-2 ⁵ / ₈ " | 1'-6 ⁵ / ₈ " | 1'-8 ⁵ / ₈ " | 1'-10 ⁵ / ₈ " |
| *FS | 5'-1 ¹ / ₁₆ " | 6'-1 ¹ / ₁₆ " | 7'-1 ¹ / ₁₆ " | 1'-1 ⁵ / ₈ " | 1'-5 ⁵ / ₈ " | 1'-7 ⁵ / ₈ " | 1'-9 ⁵ / ₈ " |
| *GS | 4'-8 ¹ / ₁₆ " | 5'-8 ¹ / ₁₆ " | 6'-8 ¹ / ₁₆ " | 0'-8 ³ / ₄ " | 1'-0 ³ / ₄ " | 1'-2 ³ / ₄ " | 1'-4 ³ / ₄ " |
| 1/0 | 1'-0 ¹ / ₂ " 1'-0" | 1'-0 ¹ / ₂ " 1'-0" | 1'-0 ¹ / ₂ " 1'-0" | 1'-0 ¹ / ₂ " 1'-0" | 1'-0 ¹ / ₂ " 1'-0" | 1'-0 ¹ / ₂ " 1'-0" | 1'-0 ¹ / ₂ " 1'-0" |
| 1/2 | 1'-2 ¹ / ₂ " 1'-2" | 1'-2 ¹ / ₂ " 1'-2" | 1'-2 ¹ / ₂ " 1'-2" | 1'-2 ¹ / ₂ " 1'-2" | 1'-2 ¹ / ₂ " 1'-2" | 1'-2 ¹ / ₂ " 1'-2" | 1'-2 ¹ / ₂ " 1'-2" |
| 1/6 | 1'-6 ¹ / ₂ " 1'-6" | 1'-6 ¹ / ₂ " 1'-6" | 1'-6 ¹ / ₂ " 1'-6" | 1'-6 ¹ / ₂ " 1'-6" | 1'-6 ¹ / ₂ " 1'-6" | 1'-6 ¹ / ₂ " 1'-6" | 1'-6 ¹ / ₂ " 1'-6" |
| 1/8 | 1'-8 ¹ / ₂ " 1'-8" | 1'-8 ¹ / ₂ " 1'-8" | 1'-8 ¹ / ₂ " 1'-8" | 1'-8 ¹ / ₂ " 1'-8" | 1'-8 ¹ / ₂ " 1'-8" | 1'-8 ¹ / ₂ " 1'-8" | 1'-8 ¹ / ₂ " 1'-8" |
| | 5010 | 6010 | 7010 | 1010 | 1410 | 1610 | 1810 |
| | 5012 | 6012 | 7012 | 1012 | 1412 | 1612 | 1812 |
| | 5016 | 6016 | 7016 | 1016 | 1416 | 1616 | 1816 |
| | 5018 | 6018 | 7018 | 1018 | 1418 | 1618 | 1818 |
| 1/0 | *GS 4'-2 ⁵ / ₁₆ " 1'-0 ¹ / ₂ " 1'-0" | 5'-2 ⁵ / ₁₆ " 1'-0 ¹ / ₂ " 1'-0" | 6'-2 ⁵ / ₁₆ " 1'-0 ¹ / ₂ " 1'-0" | | | | |
| 1/2 | 1'-2 ¹ / ₂ " 1'-2" | 1'-2 ¹ / ₂ " 1'-2" | 1'-2 ¹ / ₂ " 1'-2" | | | | |
| 1/6 | 1'-6 ¹ / ₂ " 1'-6" | 1'-6 ¹ / ₂ " 1'-6" | 1'-6 ¹ / ₂ " 1'-6" | | | | |
| 1/8 | 1'-8 ¹ / ₂ " 1'-8" | 1'-8 ¹ / ₂ " 1'-8" | 1'-8 ¹ / ₂ " 1'-8" | | | | |
| | 5010 | 6010 | 7010 | | | | |
| | 5012 | 6012 | 7012 | | | | |
| | 5016 | 6016 | 7016 | | | | |
| | 5018 | 6018 | 7018 | | | | |

NARROW
STILE

WIDE
STILE







NOT TO SCALE
 SIZES GIVEN ARE FOR UNITS WITH RIM DEVICE TYPE HARDWARE. SUBTRACT 3/16" FROM WIDTH OF FRAME FOR DOUBLE DOOR UNITS WITH MULTI-POINT HARDWARE. ADDITIONAL SIZES ARE AVAILABLE UPON REQUEST (2068 TO 3680, 4068 TO 7080)
 RO - OPENING, FS - FRAME SIZE, GS - GLASS SIZE
 PROPRIETARY NOTICE: THE INFORMATION CONTAINED IS THE SOLE PROPERTY OF FRONTLINE BLDG. PRODUCTS INC.. ANY REPRODUCTION IN PART OR AS A WHOLE WITHOUT THE WRITTEN PERMISSION OF FRONTLINE BLDG. PRODUCTS INC. IS PROHIBITED.

We also offer these great products:

Architectural Windows & Grilles
Commercial Entry Doors
Commercial Grilles
Custom Millwork
Entry Door Frame Systems
Garage Door Frames
Transom Windows & Grilles
Oversized Direct Set Windows



Connect with Us

 www.frontlinebldg.com
 salesmedford@frontlinebldg.com
 1-800-223-4792
  

LIGHT COMMERCIAL OUTSWING DOOR

SIZE TABLE
ALUMINUM CLAD WOOD - 3/4 LITE / RAISED WOOD PANEL

| SIZE | 2/6 | 3/0 | 3/6 | 5/0 | 6/0 | 7/0 |
|------|---------------------------------------|-----------|-----------|------------|------------|------------|
| *RO | 2'-8 5/8" | 3'-2 5/8" | 3'-8 5/8" | 5'-2 1/16" | 6'-2 1/16" | 7'-2 1/16" |
| *FS | 2'-7 5/8" | 3'-1 5/8" | 3'-7 5/8" | 5'-1 1/16" | 6'-1 1/16" | 7'-1 1/16" |
| *GS | 1'-8 1/8" | 2'-2 3/8" | 2'-8 1/8" | 1'-8 3/8" | 2'-2 3/8" | 2'-8 3/8" |
| 6/8 | 6'-9 1/16" 3'-4 1/2" 5'-8 1/16" | 3068 | 3668 | 5068 | 6068 | 7068 |
| 7/0 | 7'-1 1/16" 3'-8 1/2" 7'-0 1/16" | 2670 | 3670 | 5070 | 6070 | 7070 |
| 8/0 | 8'-0 2/4" 4'-8 1/16" | 2680 | 3680 | 5080 | 6080 | 7080 |

OPTIONAL STYLES

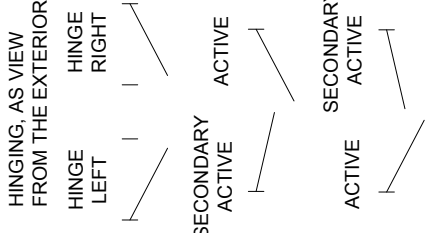
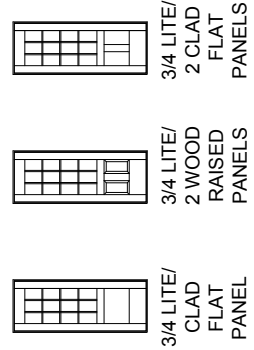

NOT TO SCALE
OPERATION IS VIEWED FROM EXTERIOR. HINGE SIDE MUST BE SPECIFIED WHEN ORDERING A SINGLE WIDE DOOR.
SIZES GIVEN ARE FOR UNITS WITH RIM DEVICE TYPE HARDWARE. SUBTRACT 3/8" FROM WIDTH OF FRAME FOR DOUBLE DOOR UNITS WITH MULTI-POINT HARDWARE. ADDITIONAL SIZES ARE AVAILABLE UPON REQUEST (2068 TO 3680, 4068 TO 7080).

* RO - OPENING, FS - FRAME SIZE, GS - GLASS SIZE.

PROPRIETARY NOTICE: THE INFORMATION CONTAINED IN THIS DRAWING IS THE SOLE PROPERTY OF FRONTLINE BLDG. PRODUCTS INC.. ANY REPRODUCTION IN PART OR AS A WHOLE WITHOUT THE WRITTEN PERMISSION OF FRONTLINE BLDG. PRODUCTS INC. IS PROHIBITED.
OSDE0914/DWG1-R1



LIGHT COMMERCIAL OUTSWING DOOR

SIZE TABLE
ALUMINUM CLAD WOOD - 1/2 LITE / RAISED WOOD PANEL

| SIZE | 2/6 | 3/0 | 3/6 | 5/0 | 6/0 | 7/0 |
|------|-----------|-----------|-----------|-------------|-------------|-------------|
| *RO | 2'-8 5/8" | 3'-2 5/8" | 3'-8 5/8" | 5'-2 11/16" | 6'-2 11/16" | 7'-2 11/16" |
| *FS | 2'-7 5/8" | 3'-1 5/8" | 3'-7 5/8" | 5'-1 11/16" | 6'-1 11/16" | 7'-1 11/16" |
| *GS | 1'-8 1/8" | 2'-2 3/8" | 2'-8 1/8" | 1'-8 1/8" | 2'-2 3/8" | 2'-8 3/8" |
| 6/8 | | | | | | |
| 7/0 | | | | | | |
| 8/0 | | | | | | |

OPTIONAL STYLES

1/2 LITE/
CLAD
FLAT
PANEL

1/2 LITE/
2 WOOD
RAISED
PANELS

1/2 LITE/
2 CLAD
FLAT
PANELS

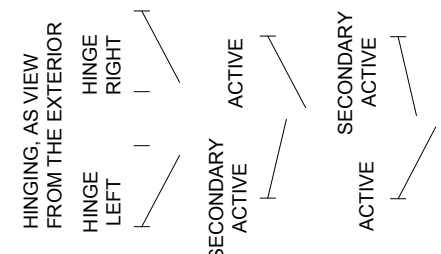

NOT TO SCALE
OPERATION IS VIEWED FROM EXTERIOR. HINGE SIDE MUST BE SPECIFIED WHEN ORDERING A SINGLE WIDE DOOR.
SIZES GIVEN ARE FOR UNITS WITH RIM DEVICE TYPE HARDWARE. SUBTRACT 3/8" FROM WIDTH OF FRAME FOR DOUBLE DOOR UNITS WITH MULTI-POINT HARDWARE. ADDITIONAL SIZES ARE AVAILABLE UPON REQUEST (2068 TO 3680, 4068 TO 7080).

* RO - OPENING, FS - FRAME SIZE, GS - GLASS SIZE.

PROPRIETARY NOTICE: THE INFORMATION CONTAINED IN THIS DRAWING IS THE SOLE PROPERTY OF FRONTLINE BLDG. PRODUCTS INC.. ANY REPRODUCTION IN PART OR AS A WHOLE WITHOUT THE WRITTEN PERMISSION OF FRONTLINE BLDG. PRODUCTS INC. IS PROHIBITED.
OSDE0914/DWG2-R1

LIGHT COMMERCIAL OUTSWINGING DOOR

SIZE TABLE
ALUMINUM CLAD WOOD - FULL VIEW

| SIZE | 2/6 | 3/0 | 3/6 | 5/0 | 6/0 | 7/0 |
|------|-----------|-----------|-----------|-------------|-------------|-------------|
| *RO | 2'-8 5/8" | 3'-2 5/8" | 3'-8 5/8" | 5'-2 11/16" | 6'-2 11/16" | 7'-2 11/16" |
| *FS | 2'-7 5/8" | 3'-1 5/8" | 3'-7 5/8" | 5'-1 11/16" | 6'-1 11/16" | 7'-1 11/16" |
| *GS | 1'-8 3/8" | 2'-2 3/8" | 2'-8 3/8" | 1'-8 3/8" | 2'-2 3/8" | 2'-8 3/8" |
| 6/8 | 2668 | 3068 | 3668 | 5068 | 6068 | 7068 |
| 7/0 | 2670 | 3070 | 3670 | 5070 | 6070 | 7070 |
| 8/0 | 2680 | 3080 | 3680 | 5080 | 6080 | 7080 |

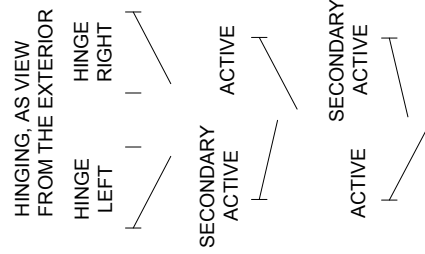

NOT TO SCALE
OPERATION IS VIEWED FROM EXTERIOR. HINGE SIDE MUST BE SPECIFIED WHEN ORDERING A SINGLE WIDE DOOR.
SIZES GIVEN ARE FOR UNITS WITH RIM DEVICE TYPE HARDWARE. SUBTRACT 3/16" FROM WIDTH OF FRAME FOR DOUBLE DOOR UNITS WITH MULTI-POINT HARDWARE. ADDITIONAL SIZES ARE AVAILABLE UPON REQUEST (2068 TO 3680, 4068 TO 7080).

* RO - OPENING, FS - FRAME SIZE, GS - GLASS SIZE.

PROPRIETARY NOTICE: THE INFORMATION CONTAINED IN THIS DRAWING IS THE SOLE PROPERTY OF FRONTLINE BLDG. PRODUCTS INC.. ANY REPRODUCTION IN PART OR AS A WHOLE WITHOUT THE WRITTEN PERMISSION OF FRONTLINE BLDG. PRODUCTS INC. IS PROHIBITED.
OSDE0914/DWG3-R1



LIGHT COMMERCIAL OUTSWING DOOR

SIZE TABLE
ALUMINUM CLAD WOOD - SIDELITE

| SIZE | 1/0 | 1/4 | 1/6 | 1/8 |
|------|-----------|-----------|-----------|------------|
| *RO | 1'-2 5/8" | 1'-6 5/8" | 1'-8 5/8" | 1'-10 5/8" |
| *FS | 1'-1 5/8" | 1'-5 5/8" | 1'-7 5/8" | 1'-9 5/8" |
| *GS | 0'-8 5/8" | 1'-0 5/8" | 1'-2 5/8" | 1'-4 5/8" |
| 6/8 | 1068 | 1468 | 1668 | 1868 |
| 7/0 | 1070 | 1470 | 1670 | 1870 |
| 8/0 | 1080 | 1480 | 1680 | 1880 |

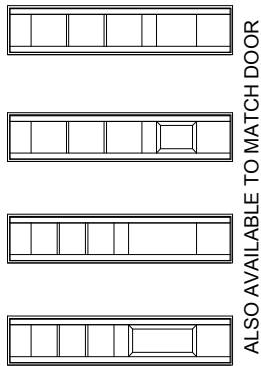

ALSO AVAILABLE TO MATCH DOOR

NOT TO SCALE
ADDITIONAL SIZES MAY BE AVAILABLE UPON REQUEST (1068 TO 1880).

* RO - OPENING, FS - FRAME SIZE, GS - GLASS SIZE.

PROPRIETARY NOTICE: THE INFORMATION CONTAINED IN THIS DRAWING IS THE SOLE PROPERTY OF FRONTLINE BLDG. PRODUCTS INC.. ANY REPRODUCTION IN PART OR AS A WHOLE WITHOUT THE WRITTEN PERMISSION OF FRONTLINE BLDG. PRODUCTS INC. IS PROHIBITED.
OSDE0914/DWG4-R1



LIGHT COMMERCIAL OUTSWING DOOR

SIZE TABLE
ALUMINUM CLAD WOOD - TRANSOM

| SIZE | 2/6 | 3/0 | 3/6 | 5/0 | 6/0 | 7/0 |
|--------------|-----------|-----------|-----------|------------|------------|------------|
| *RO | 2'-8 5/8" | 3'-2 5/8" | 3'-8 5/8" | 5'-2 1/16" | 6'-2 1/16" | 7'-2 1/16" |
| *FS | 2'-7 5/8" | 3'-1 5/8" | 3'-7 5/8" | 5'-1 1/16" | 6'-1 1/16" | 7'-1 1/16" |
| | 2'-2 3/4" | 2'-8 3/4" | 3'-2 3/4" | 2'-2 3/4" | 2'-8 3/4" | 3'-2 3/4" |
| 1/0 | 2610 | 3010 | 3610 | 5010 | 6010 | 7010 |
| 1/2 | 2612 | 3012 | 3612 | 5012 | 6012 | 7012 |
| 1/6 | 2616 | 3016 | 3616 | 5016 | 6016 | 7016 |
| 1/8 | 2618 | 3018 | 3618 | 5018 | 6018 | 7018 |
| NARROW STILE | | | | | | |
| 1/0 | *GS 2610 | 3010 | 3610 | 5010 | 6010 | 7010 |
| 1/2 | 2612 | 3012 | 3612 | 5012 | 6012 | 7012 |
| 1/6 | 2616 | 3016 | 3616 | 5016 | 6016 | 7016 |
| 1/8 | 2618 | 3018 | 3618 | 5018 | 6018 | 7018 |
| WIDE STILE | | | | | | |
| 1/0 | *GS 2610 | 3010 | 3610 | 5010 | 6010 | 7010 |
| 1/2 | 2612 | 3012 | 3612 | 5012 | 6012 | 7012 |
| 1/6 | 2616 | 3016 | 3616 | 5016 | 6016 | 7016 |
| 1/8 | 2618 | 3018 | 3618 | 5018 | 6018 | 7018 |

NOT TO SCALE

SIZES GIVEN ARE FOR TRANSOMS MULLED ABOVE UNITS WITH RIM DEVICE TYPE HARDWARE. SUBTRACT 3/16" FROM WIDTH OF FRAME FOR TRANSOM MULLED ABOVE DOUBLE DOOR UNITS WITH MULTIPOINT HARDWARE. ADDITIONAL SIZE MAY BE AVAILABLE UPON REQUEST.

* RO - OPENING, FS - FRAME SIZE, GS - GLASS SIZE.

PROPRIETARY NOTICE: THE INFORMATION CONTAINED IN THIS DRAWING IS THE SOLE PROPERTY OF FRONTLINE BLDG. PRODUCTS INC. ANY REPRODUCTION IN PART OR AS A WHOLE WITHOUT THE WRITTEN PERMISSION OF FRONTLINE BLDG. PRODUCTS INC. IS PROHIBITED.
OSDE0914/DWG5-R1



LIGHT COMMERCIAL OUTSWING DOOR
 SIZE TABLE
 ALUMINUM CLAD WOOD - TRANSOM

| SIZE | 5/0 | 6/0 | 7/0 | 1/0 | 1/4 | 1/6 | 1/8 |
|------|-------------|-------------|-------------|-----------|-----------|-----------|------------|
| *RO | 5'-2 11/16" | 6'-2 11/16" | 7'-2 11/16" | 1'-2 5/8" | 1'-6 5/8" | 1'-8 5/8" | 1'-10 5/8" |
| *FS | 5'-1 11/16" | 6'-1 11/16" | 7'-1 11/16" | 1'-1 5/8" | 1'-5 5/8" | 1'-7 5/8" | 1'-9 5/8" |
| *GS | 4'-8 13/16" | 5'-8 13/16" | 6'-8 13/16" | 0'-8 3/4" | 1'-0 3/4" | 1'-2 3/4" | 1'-4 3/4" |
| 1/0 | 5010 | 6010 | 7010 | 1010 | 1410 | 1610 | 1810 |
| 1/2 | 5012 | 6012 | 7012 | 1012 | 1412 | 1612 | 1812 |
| 1/6 | 5016 | 6016 | 7016 | 1016 | 1416 | 1616 | 1816 |
| 1/8 | 5018 | 6018 | 7018 | 1018 | 1418 | 1618 | 1818 |
| 1/0 | 4'-2 5/16" | 5'-2 5/16" | 6'-2 5/16" | | | | |
| *GS | | | | | | | |
| 1/0 | 5010 | 6010 | 7010 | | | | |
| 1/2 | 5012 | 6012 | 7012 | | | | |
| 1/6 | 5016 | 6016 | 7016 | | | | |
| 1/8 | 5018 | 6018 | 7018 | | | | |

NARROW
STILE

WIDE
STILE

NOT TO SCALE
 SIZES GIVEN ARE FOR TRANSOMS MULLED ABOVE UNITS WITH RIM DEVICE TYPE HARDWARE. SUBTRACT 3/16" FROM WIDTH OF FRAME FOR TRANSOM
 MULLED ABOVE DOUBLE DOOR UNITS WITH MULTIPOINT HARDWARE.
 ADDITIONAL SIZE MAY BE AVAILABLE UPON REQUEST.

* RO - OPENING, FS - FRAME SIZE, GS - GLASS SIZE.

PROPRIETARY NOTICE: THE INFORMATION CONTAINED IN THIS DRAWING IS THE SOLE PROPERTY OF FRONTLINE BLDG. PRODUCTS INC. ANY REPRODUCTION IN PART OR AS A WHOLE WITHOUT THE WRITTEN PERMISSION OF FRONTLINE BLDG. PRODUCTS INC. IS PROHIBITED.

OSDE0914/DWG6-R1

LIGHT COMMERCIAL CLAD OUTSWING DOOR

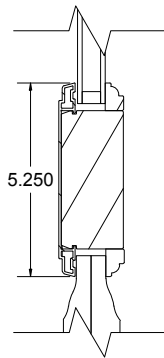
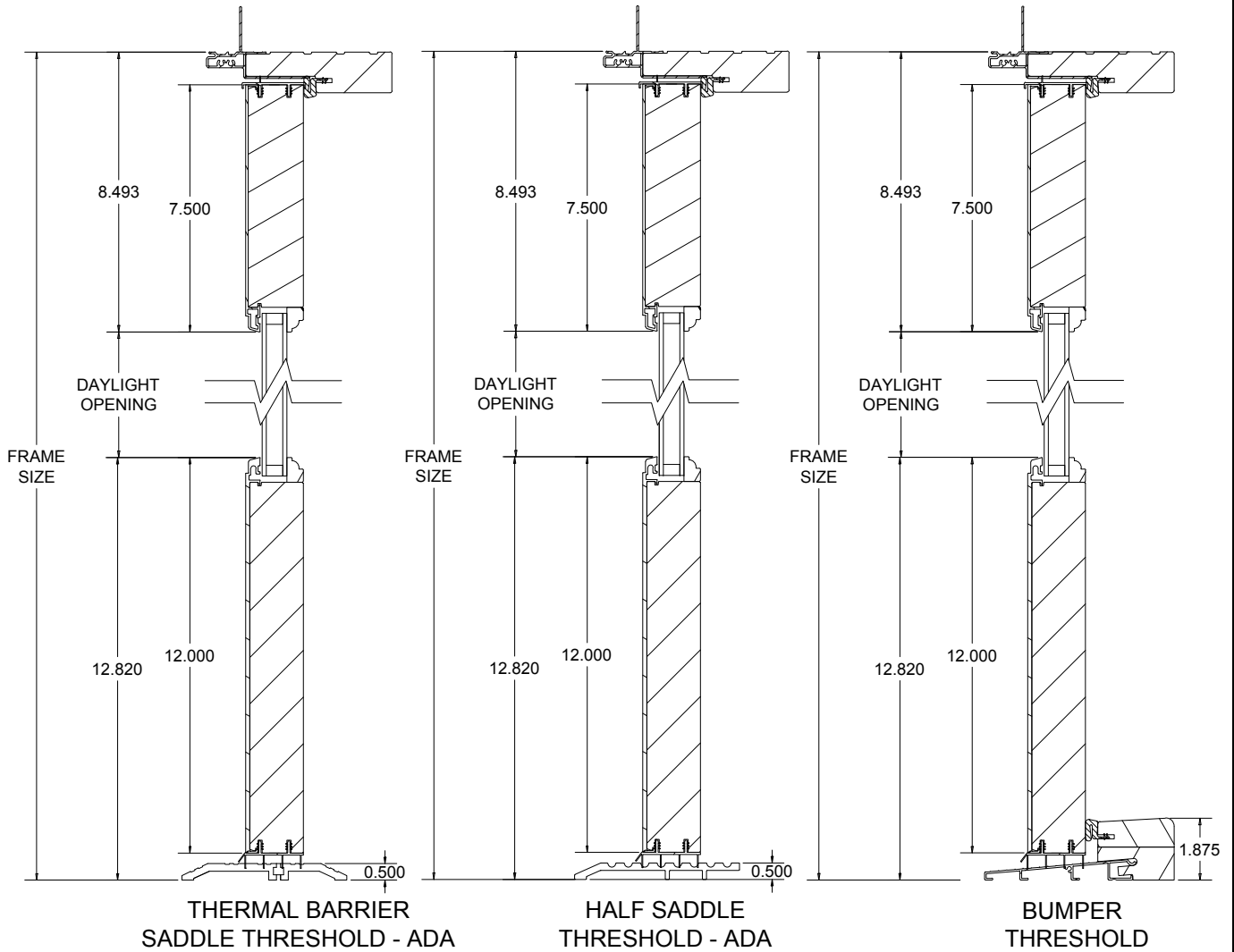

MID-RAIL WITH
WOOD RAISED PANEL

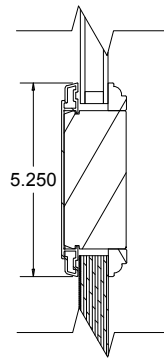

MID-RAIL WITH
ALUMINUM CLAD PANEL

NOT TO SCALE

PROPRIETARY NOTICE: THE INFORMATION CONTAINED IN THIS DRAWING IS THE SOLE PROPERTY OF FRONTLINE BLDG. PRODUCTS INC.. ANY REPRODUCTION IN PART OR AS A WHOLE WITHOUT THE WRITTEN PERMISSION OF FRONTLINE BLDG. PRODUCTS INC. IS PROHIBITED.

OSDS0914/DWG1-REV1

LIGHT COMMERCIAL CLAD OUTSWING DOOR

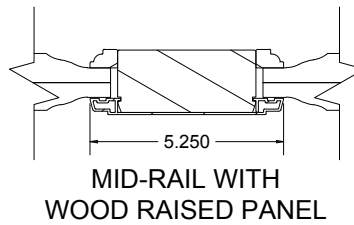
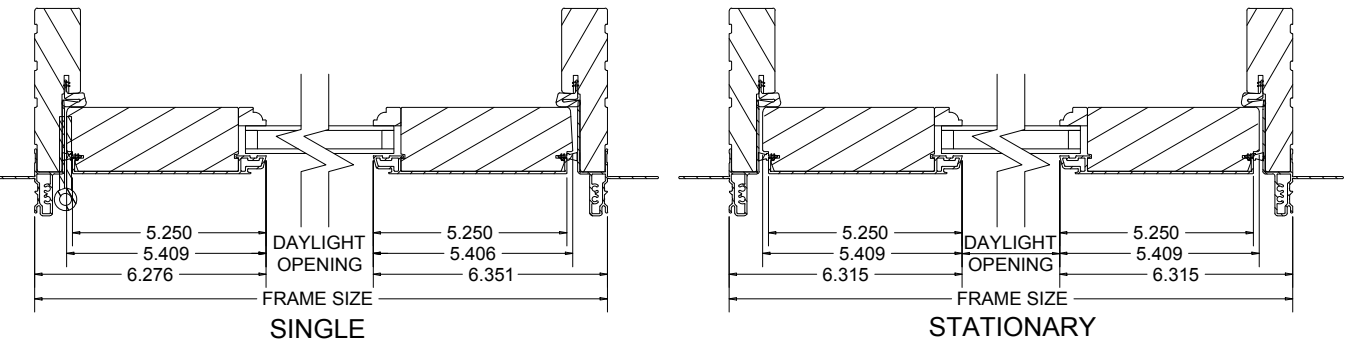
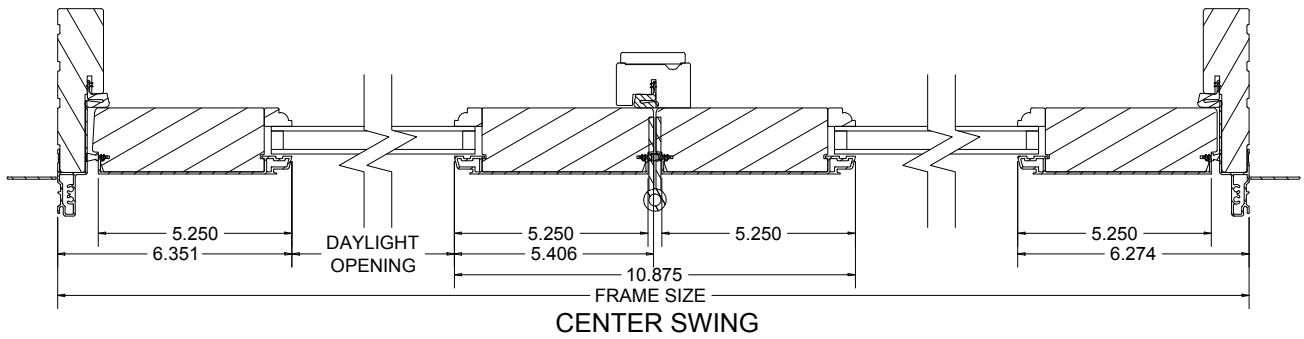
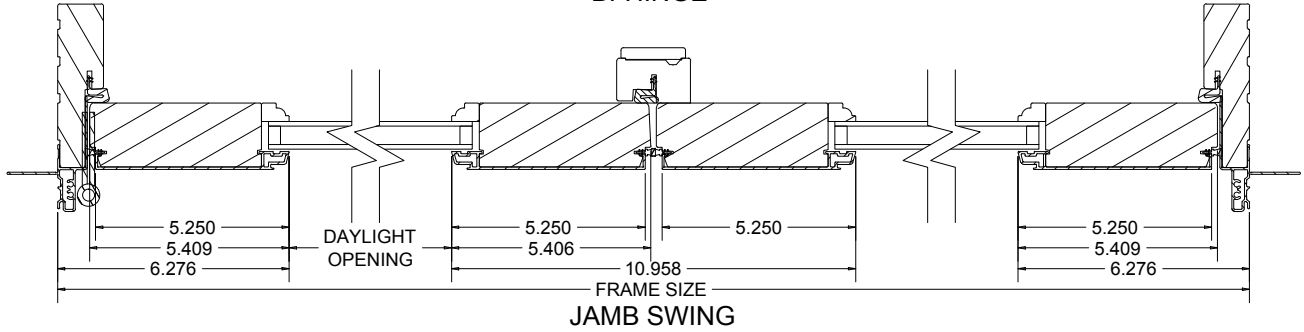
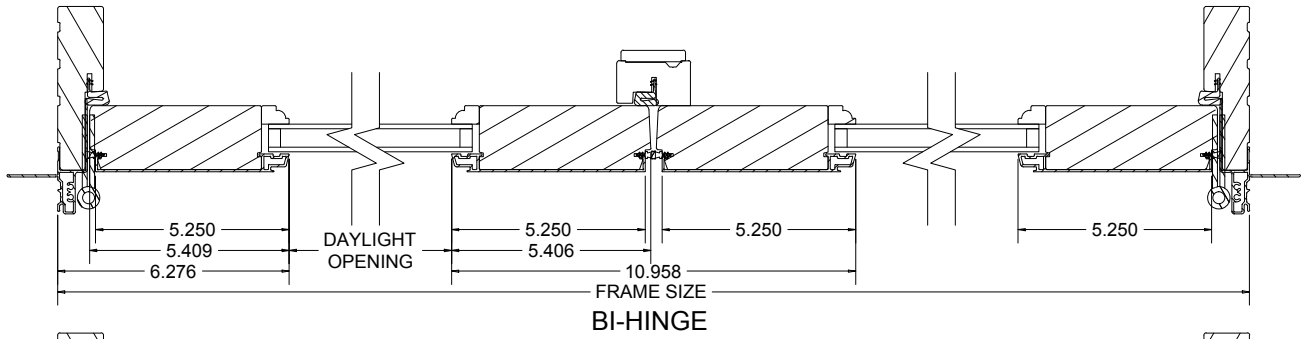

NOT TO SCALE

PROPRIETARY NOTICE: THE INFORMATION CONTAINED IN THIS DRAWING IS THE SOLE PROPERTY OF FRONTLINE BLDG. PRODUCTS INC.. ANY REPRODUCTION IN PART OR AS A WHOLE WITHOUT THE WRITTEN PERMISSION OF FRONTLINE BLDG. PRODUCTS INC. IS PROHIBITED.

OSDS0914/DWG2-REV1

**LIGHT COMMERCIAL CLAD OUTSWING DOOR
- SIDELITE**

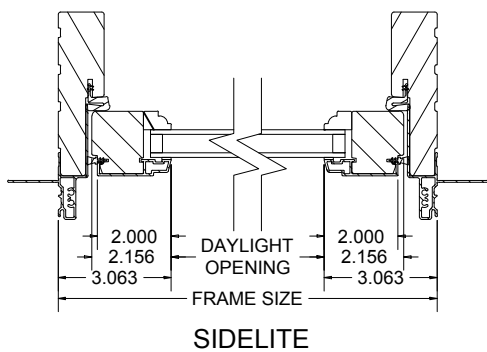
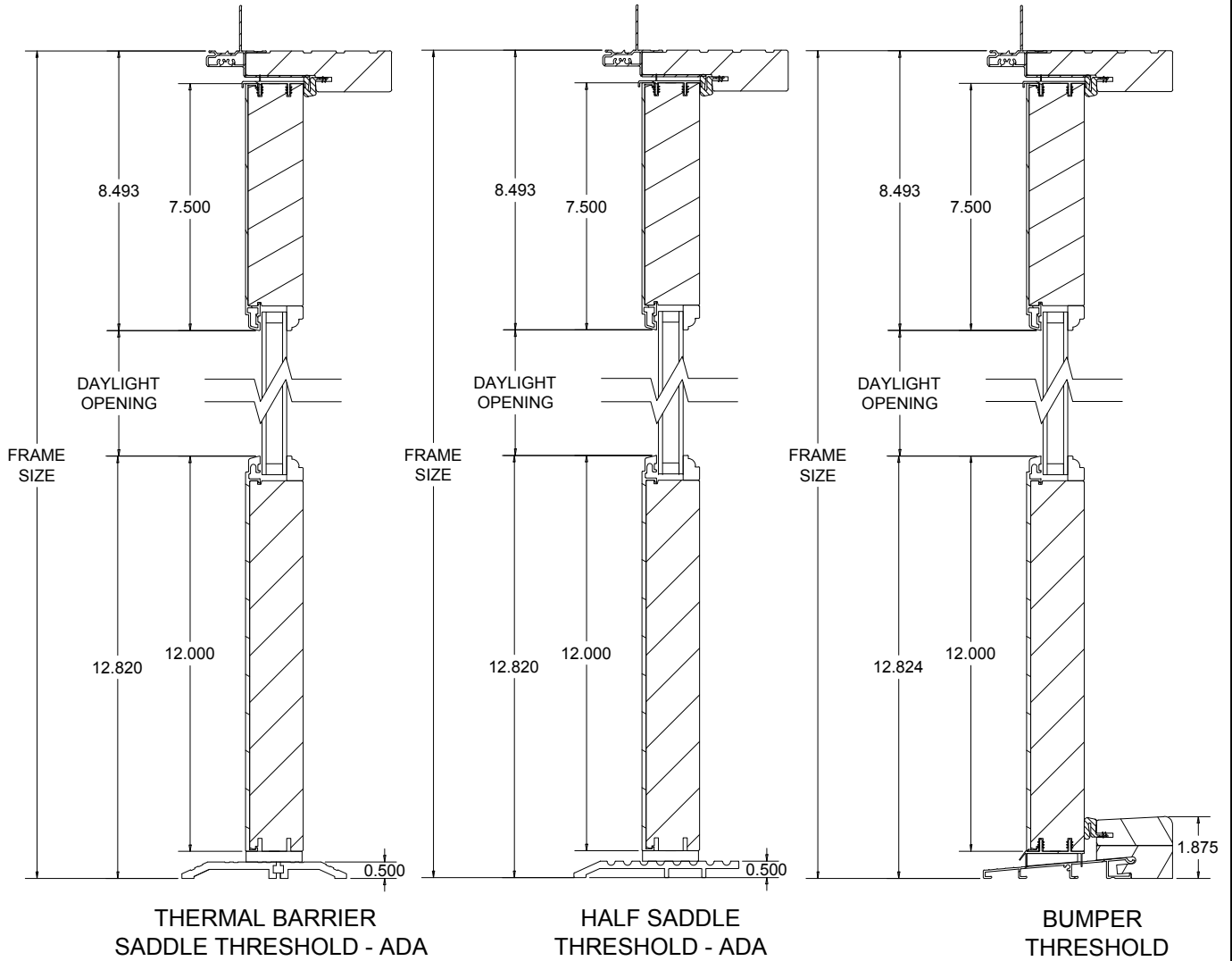

NOT TO SCALE

PROPRIETARY NOTICE: THE INFORMATION CONTAINED IN THIS DRAWING IS THE SOLE PROPERTY OF FRONTLINE BLDG. PRODUCTS INC.. ANY REPRODUCTION IN PART OR AS A WHOLE WITHOUT THE WRITTEN PERMISSION OF FRONTLINE BLDG. PRODUCTS INC. IS PROHIBITED.

OSDS0914/DWG3-REV1

**LIGHT COMMERCIAL CLAD OUTSWING DOOR
- TRANSOM**

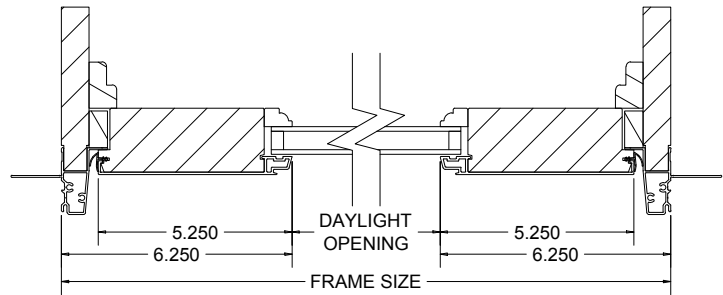
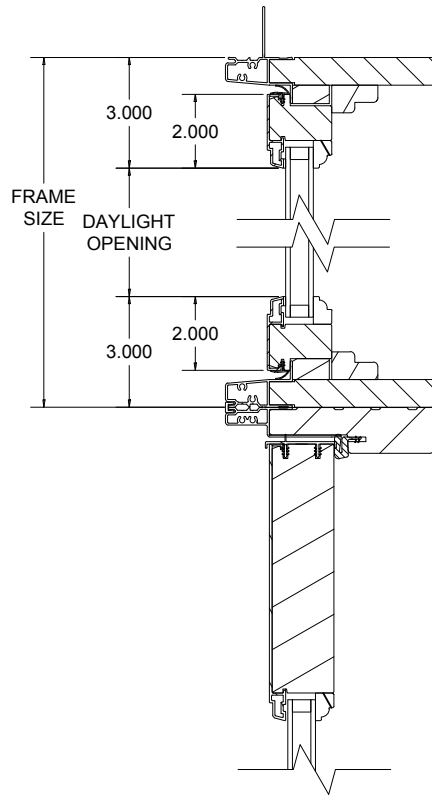

**WIDE STILE TRANSOM -
SINGLE SASH**

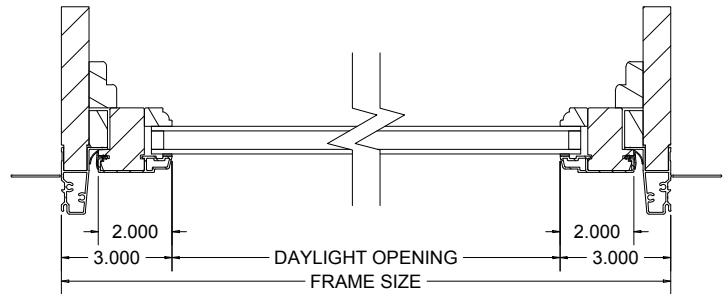

**NARROW STILE TRANSOM -
SINGLE SASH**

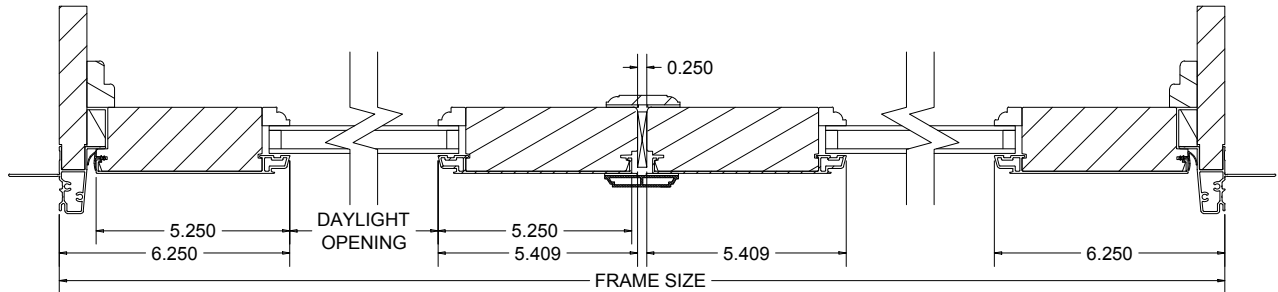

**WIDE STILE TRANSOM -
DOUBLE SASH**

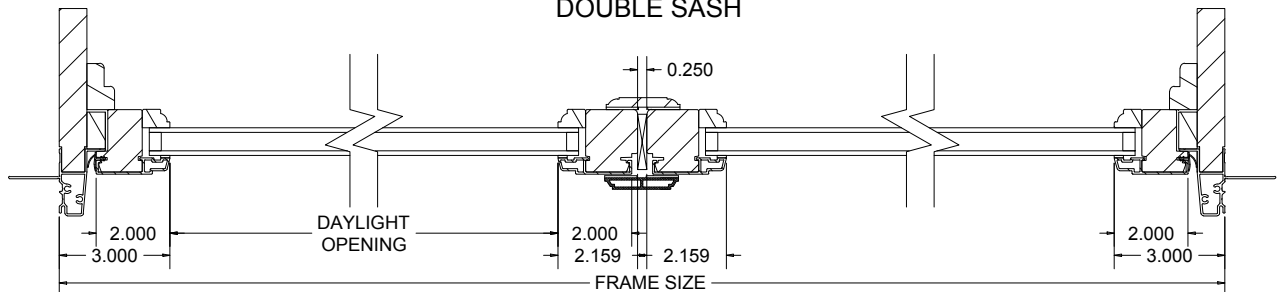

**NARROW STILE TRANSOM -
DOUBLE SASH**

NOT TO SCALE

PROPRIETARY NOTICE: THE INFORMATION CONTAINED IN THIS DRAWING IS THE SOLE PROPERTY OF FRONTLINE BLDG. PRODUCTS INC.. ANY REPRODUCTION IN PART OR AS A WHOLE WITHOUT THE WRITTEN PERMISSION OF FRONTLINE BLDG. PRODUCTS INC. IS PROHIBITED.

OSDS0914/DWG4-REV1

LIGHT COMMERCIAL CLAD OUTSWING DOOR
- FULL VIEW DOOR/SIDELITE



| LIGHT COMMERCIAL OUTSWING DOOR | | | | | | | | | | | | | |
|--------------------------------|---------|-------------------------------------|--------|-------------------------------------|--------|-------------------------------------|--------|------------------------------------|-------|------------------|-------|---------------------------------------|--------|
| Unit Type | Callout | Frame Size | | Rough Opening | | Masonry Opening | | Glass Size | | Daylight Opening | | Sash Size | |
| | | Ft-in | mm | Ft-in | mm | Ft-in | mm | Ft-in | mm | Ft-in | mm | Ft-in | mm |
| Light Commercial Door WIDTH | 2/6 | 2'-7 ⁵ / ₈ " | (803) | 2'-8 ⁵ / ₈ " | (829) | 2'-8 ¹ / ₈ " | (841) | 1'-8 ¹ / ₈ " | (511) | 1'-7" | (511) | 2'-5 ¹³ / ₁₆ " | (757) |
| | 3/0 | 3'-1 ⁵ / ₈ " | (956) | 3'-2 ⁵ / ₈ " | (981) | 3'-2 ¹ / ₈ " | (994) | 2'-2 ¹ / ₈ " | (664) | 2'-1" | (664) | 2'-11 ¹³ / ₁₆ " | (910) |
| | 3/6 | 3'-7 ⁵ / ₈ " | (1108) | 3'-8 ⁵ / ₈ " | (1133) | 3'-8 ¹ / ₈ " | (1146) | 2'-8 ¹ / ₈ " | (816) | 2'-7" | (816) | 3'-5 ¹³ / ₁₆ " | (1062) |
| | 5/0 | 5'-1 ¹ / ₁₆ " | (1567) | 5'-2 ¹ / ₁₆ " | (1592) | 5'-2 ³ / ₁₆ " | (1580) | 1'-8 ¹ / ₈ " | (511) | 1'-7" | (511) | 2'-5 ¹³ / ₁₆ " | (757) |
| | 6/0 | 6'-1 ¹ / ₁₆ " | (1872) | 6'-2 ¹ / ₁₆ " | (1897) | 6'-2 ³ / ₁₆ " | (1884) | 2'-2 ¹ / ₈ " | (664) | 2'-1" | (664) | 2'-11 ¹³ / ₁₆ " | (910) |
| | 7/0 | 7'-1 ¹ / ₁₆ " | (2176) | 7'-2 ¹ / ₁₆ " | (2202) | 7'-2 ³ / ₁₆ " | (2189) | 2'-8 ¹ / ₈ " | (816) | 2'-7" | (816) | 3'-5 ¹³ / ₁₆ " | (1062) |

| LIGHT COMMERCIAL OUTSWING DOOR AND SIDELITE | | | | | | | | | | | | | |
|---|---------|-------------------------------------|--------|-------------------------------------|--------|--------------------------------------|--------|--------------------------------------|--------|-------------------------------------|--------|-------------------------------------|--------|
| Unit Type | Callout | Frame Size | | Rough Opening | | Masonry Opening | | Glass Size | | Daylight Opening | | Sash Size | |
| | | Ft-in | mm | Ft-in | mm | Ft-in | mm | Ft-in | mm | Ft-in | mm | Ft-in | mm |
| Light Commercial Door HEIGHT | 6/8 | 6'-8 ⁹ / ₁₆ " | (2046) | 6'-9 ¹ / ₁₆ " | (2008) | 6'-8 ¹³ / ₁₆ " | (2053) | 5'-0 ³ / ₈ " | (1534) | 4'-11 ¹ / ₄ " | (1505) | 6'-6 ³ / ₄ " | (2000) |
| | 7/0 | 7'-0 ⁹ / ₁₆ " | (2148) | 7'-1 ¹ / ₁₆ " | (2008) | 7'-0 ¹³ / ₁₆ " | (2154) | 5'-4 ³ / ₈ " | (1635) | 5'-3 ¹ / ₄ " | (1607) | 6'-10 ³ / ₄ " | (2102) |
| | 8/0 | 8'-0" | (2438) | 8'-0 ¹ / ₂ " | (2046) | 8'-0 ¹ / ₄ " | (2445) | 6'-3 ¹³ / ₁₆ " | (1926) | 6'-2 ¹ / ₁₆ " | (1897) | 7'-10 ³ / ₄ " | (2392) |
| | | | | | | | | | | | | | |

| LIGHT COMMERCIAL OUTSWING DOOR SIDELITE | | | | | | | | | | | | | |
|---|---------|------------------------------------|-------|-------------------------------------|-------|-------------------------------------|-------|------------------------------------|-------|-------------------------------------|-------|---------------------------------------|-------|
| Unit Type | Callout | Frame Size | | Rough Opening | | Masonry Opening | | Glass Size | | Daylight Opening | | Sash Size | |
| | | Ft-in | mm | Ft-in | mm | Ft-in | mm | Ft-in | mm | Ft-in | mm | Ft-in | mm |
| Light Commercial Door WIDTH | 1/0 | 1'-1 ⁵ / ₈ " | (346) | 1'-2 ⁵ / ₈ " | (371) | 1'-2 ¹ / ₈ " | (359) | 0'-8 ⁵ / ₈ " | (219) | 0'-7 ¹ / ₂ " | (191) | 0'-11 ¹³ / ₁₆ " | (300) |
| | 1/4 | 1'-5 ⁵ / ₈ " | (448) | 1'-6 ⁵ / ₈ " | (473) | 1'-6 ¹ / ₈ " | (460) | 1'-0 ⁵ / ₈ " | (321) | 0'-11 ¹ / ₂ " | (292) | 1'-3 ¹³ / ₁₆ " | (402) |
| | 1/6 | 1'-7 ⁵ / ₈ " | (498) | 1'-8 ⁵ / ₈ " | (524) | 1'-8 ¹ / ₈ " | (511) | 1'-2 ⁵ / ₈ " | (371) | 1'-1 ¹ / ₂ " | (343) | 1'-5 ¹³ / ₁₆ " | (452) |
| | 1/8 | 1'-9 ⁵ / ₈ " | (549) | 1'-10 ⁵ / ₈ " | (575) | 1'-10 ¹ / ₈ " | (562) | 1'-4 ⁵ / ₈ " | (422) | 1'-3 ¹ / ₂ " | (394) | 1'-7 ¹³ / ₁₆ " | (503) |
| | | | | | | | | | | | | | |

OPERATION IS VIEWED FROM EXTERIOR. HINGE SIDE MUST BE SPECIFIED WHEN ORDERING A SINGLE WIDE DOOR.
 SIZES GIVEN ARE FOR UNITS WITH RIM DEVICE TYPE HARDWARE. SUBTRACT ³/₁₆" FROM WIDTH OF A DOUBLE DOOR UNIT WITH MULTI-POINT HARDWARE.
 ADDITIONAL SIZES ARE AVAILABLE UPON REQUEST (2068 TO 3680, 4068 TO 7080).

PROPRIETARY NOTICE: THE INFORMATION CONTAINED IN THIS DRAWING IS THE SOLE PROPERTY OF FRONTLINE BLDG. PRODUCTS INC.. ANY REPRODUCTION IN PART OR AS A WHOLE WITHOUT THE WRITTEN PERMISSION OF FRONTLINE BLDG. PRODUCTS INC. IS PROHIBITED.

LIGHT COMMERCIAL CLAD OUTSWING DOOR - TRANSOM



| LIGHT COMMERCIAL OUTSWING DOOR SASH SET TRANSOM (NARROW STILE) | | | | | | | | | | | | | |
|--|---------|--------------------------------------|--------|--------------------------------------|--------|-------------------------------------|--------|------------------------------------|-------|------------------------------------|-------|-------------------------------------|--------|
| Unit Type | Callout | Frame Size | | Rough Opening | | Masonry Opening | | Glass Size | | Daylight Opening | | Sash Size | |
| | | Ft-in | mm | Ft-in | mm | Ft-in | mm | Ft-in | mm | Ft-in | mm | Ft-in | mm |
| Light Commercial Door Transom WIDTH | 2/6 | 2'-7 ⁵ / ₈ " | (803) | 2'-8 ⁵ / ₈ " | (829) | 2'-8 ¹ / ₈ " | (841) | 2'-2 ³ / ₄ " | (679) | 2'-1 ⁵ / ₈ " | (651) | 2'-5 ⁵ / ₈ " | (752) |
| | 3/0 | 3'-1 ⁵ / ₈ " | (956) | 3'-2 ⁵ / ₈ " | (981) | 3'-2 ¹ / ₈ " | (994) | 2'-8 ³ / ₄ " | (832) | 2'-7 ⁵ / ₈ " | (803) | 2'-11 ⁵ / ₈ " | (905) |
| | 3/6 | 3'-7 ⁵ / ₈ " | (1108) | 3'-8 ⁵ / ₈ " | (1133) | 3'-8 ¹ / ₈ " | (1146) | 3'-2 ³ / ₄ " | (984) | 3'-1 ⁵ / ₈ " | (956) | 3'-5 ⁵ / ₈ " | (1057) |
| | 5/0 | 5'-1 ¹¹ / ₁₆ " | (1567) | 5'-2 ¹¹ / ₁₆ " | (1592) | 5'-2 ³ / ₁₆ " | (1580) | 2'-2 ³ / ₄ " | (679) | 2'-1 ⁵ / ₈ " | (651) | 2'-5 ⁵ / ₈ " | (752) |
| | 6/0 | 6'-1 ¹¹ / ₁₆ " | (1872) | 6'-2 ¹¹ / ₁₆ " | (1897) | 6'-2 ³ / ₁₆ " | (1884) | 2'-8 ³ / ₄ " | (832) | 2'-7 ⁵ / ₈ " | (803) | 2'-11 ⁵ / ₈ " | (905) |
| | 7/0 | 7'-1 ¹¹ / ₁₆ " | (2176) | 7'-2 ¹¹ / ₁₆ " | (2202) | 7'-2 ³ / ₁₆ " | (2189) | 3'-2 ³ / ₄ " | (984) | 3'-1 ⁵ / ₈ " | (956) | 3'-5 ⁵ / ₈ " | (1057) |

| LIGHT COMMERCIAL OUTSWING DOOR SASH SET TRANSOM (WIDE STILE) | | | | | | | | | | | | | |
|--|---------|--------------------------------------|--------|--------------------------------------|--------|-------------------------------------|--------|------------------------------------|-------|------------------------------------|-------|-------------------------------------|--------|
| Unit Type | Callout | Frame Size | | Rough Opening | | Masonry Opening | | Glass Size | | Daylight Opening | | Sash Size | |
| | | Ft-in | mm | Ft-in | mm | Ft-in | mm | Ft-in | mm | Ft-in | mm | Ft-in | mm |
| Light Commercial Door Transom WIDTH | 2/6 | 2'-7 ⁵ / ₈ " | (803) | 2'-8 ⁵ / ₈ " | (829) | 2'-8 ¹ / ₈ " | (841) | 1'-8 ¹ / ₄ " | (514) | 1'-7 ¹ / ₈ " | (486) | 2'-5 ⁵ / ₈ " | (752) |
| | 3/0 | 3'-1 ⁵ / ₈ " | (956) | 3'-2 ⁵ / ₈ " | (981) | 3'-2 ¹ / ₈ " | (994) | 2'-2 ¹ / ₄ " | (667) | 2'-1 ¹ / ₈ " | (638) | 2'-11 ⁵ / ₈ " | (905) |
| | 3/6 | 3'-7 ⁵ / ₈ " | (1108) | 3'-8 ⁵ / ₈ " | (1133) | 3'-8 ¹ / ₈ " | (1146) | 2'-8 ¹ / ₄ " | (819) | 2'-7 ¹ / ₈ " | (791) | 3'-5 ⁵ / ₈ " | (1057) |
| | 5/0 | 5'-1 ¹¹ / ₁₆ " | (1567) | 5'-2 ¹¹ / ₁₆ " | (1592) | 5'-2 ³ / ₁₆ " | (1580) | 1'-8 ¹ / ₄ " | (514) | 1'-7 ¹ / ₈ " | (486) | 2'-5 ⁵ / ₈ " | (752) |
| | 6/0 | 6'-1 ¹¹ / ₁₆ " | (1872) | 6'-2 ¹¹ / ₁₆ " | (1897) | 6'-2 ³ / ₁₆ " | (1884) | 2'-2 ¹ / ₄ " | (667) | 2'-1 ¹ / ₈ " | (638) | 2'-11 ⁵ / ₈ " | (905) |
| | 7/0 | 7'-1 ¹¹ / ₁₆ " | (2176) | 7'-2 ¹¹ / ₁₆ " | (2202) | 7'-2 ³ / ₁₆ " | (2189) | 2'-8 ¹ / ₄ " | (819) | 2'-7 ¹ / ₈ " | (791) | 3'-5 ⁵ / ₈ " | (1057) |

| LIGHT COMMERCIAL OUTSWING DOOR SIDELITE SASH SET TRANSOM | | | | | | | | | | | | | |
|--|---------|------------------------------------|-------|-------------------------------------|-------|-------------------------------------|-------|------------------------------------|-------|-------------------------------------|-------|-------------------------------------|-------|
| Unit Type | Callout | Frame Size | | Rough Opening | | Masonry Opening | | Glass Size | | Daylight Opening | | Sash Size | |
| | | Ft-in | mm | Ft-in | mm | Ft-in | mm | Ft-in | mm | Ft-in | mm | Ft-in | mm |
| Light Commercial Door Transom HEIGHT | 1/0 | 1'-1 ⁵ / ₈ " | (346) | 1'-2 ⁵ / ₈ " | (371) | 1'-2 ¹ / ₈ " | (359) | 0'-8 ³ / ₄ " | (222) | 0'-7 ⁵ / ₈ " | (193) | 0'-11 ⁵ / ₈ " | (295) |
| | 1/4 | 1'-5 ⁵ / ₈ " | (448) | 1'-6 ⁵ / ₈ " | (473) | 1'-6 ¹ / ₈ " | (460) | 1'-0 ³ / ₄ " | (324) | 0'-11 ⁵ / ₈ " | (295) | 1'-3 ⁵ / ₈ " | (397) |
| | 1/6 | 1'-7 ⁵ / ₈ " | (498) | 1'-8 ⁵ / ₈ " | (524) | 1'-8 ¹ / ₈ " | (511) | 1'-2 ³ / ₄ " | (375) | 1'-1 ⁵ / ₈ " | (346) | 1'-5 ⁵ / ₈ " | (448) |
| | 1/8 | 1'-9 ⁵ / ₈ " | (549) | 1'-10 ⁵ / ₈ " | (575) | 1'-10 ¹ / ₈ " | (562) | 1'-4 ³ / ₄ " | (425) | 1'-3 ⁵ / ₈ " | (397) | 1'-7 ⁵ / ₈ " | (498) |
| | | | | | | | | | | | | | |
| | | | | | | | | | | | | | |

SIZES GIVEN ARE FOR UNITS MULLED ABOVE DOORS WITH RIM DEVICE TYPE HARDWARE. SUBTRACT ³/₁₆" FROM WIDTH, IF MULLED ABOVE DOUBLE DOOR WITH MULTI-POINT HARDWARE. ADDITIONAL SIZES ARE AVAILABLE UPON REQUEST.

PROPRIETARY NOTICE: THE INFORMATION CONTAINED IN THIS DRAWING IS THE SOLE PROPERTY OF FRONTLINE BLDG. PRODUCTS INC.. ANY REPRODUCTION IN PART OR AS A WHOLE WITHOUT THE WRITTEN PERMISSION OF FRONTLINE BLDG. PRODUCTS INC. IS PROHIBITED.

Performance Data

THERMAL PERFORMANCE:

| Product | NFRC CPD # | U-Factor | SHGC | VT | ENERGY STAR |
|---|---------------------|----------|------|------|--------------|
| 100 Wood Direct Set | | | | | |
| 71/38 LowE IG | BNB-N-1-00054-00001 | 0.27 | 0.35 | 0.63 | N, NC |
| 366 LowE IG | BNB-N-1-00058-00006 | 0.27 | 0.24 | 0.58 | N, NC, SC, S |
| 300 Aluminum Clad Wood Direct Set | | | | | |
| 71/38 LowE IG | BNB-N-3-00092-00001 | 0.29 | 0.35 | 0.63 | N, NC |
| 366 LowE IG | BNB-N-3-00096-00006 | 0.29 | 0.25 | 0.58 | N, NC, SC, S |
| 400 Aluminum Clad Wood Casement Picture | | | | | |
| 71/38 LowE IG | BNB-N-4-00004-00011 | 0.29 | 0.31 | 0.56 | N, NC |
| 366 LowE IG | BNB-N-4-00010-00001 | 0.28 | 0.22 | 0.51 | N, NC, SC, S |
| 500 Aluminum Clad Wood Outswing Door-Full Lite | | | | | |
| 71/38 LowE IG | BNB-N-5-00023-00011 | 0.33 | 0.20 | 0.35 | - |
| 366 LowE IG | BNB-N-5-00030-00001 | 0.31 | 0.15 | 0.32 | - |

Conditions:

- 71/38 LowE = Guardian RLE 71-38 w/ Argon
- 366 LowE = Cardinal 366 w/ Argon
- 1/8" Glass
- 1/2" Aluminum Glass Spacer for 71-38 LowE and 1/2" Stainless Steel for 366 LowE
- 3/4" Jamb for Direct Sets
- No Grilles

Abbreviations:

- SHGC = Solar Heat Gain Coefficient
- VT = Visual Light Transmittance
- ENERGY STAR Zones: N=Northern, NC=North Central, SC=South Central, S=Southern.

Thermal performance values for all options are in NFRC's Certified Products Directory,

<http://search.nfrc.org/Search/SearchDefault.aspx>

ENERGY STAR Version 6.0, Version 5.0 for Northern Zone

Performance Data

ENERGY STAR VERSION 6.0:

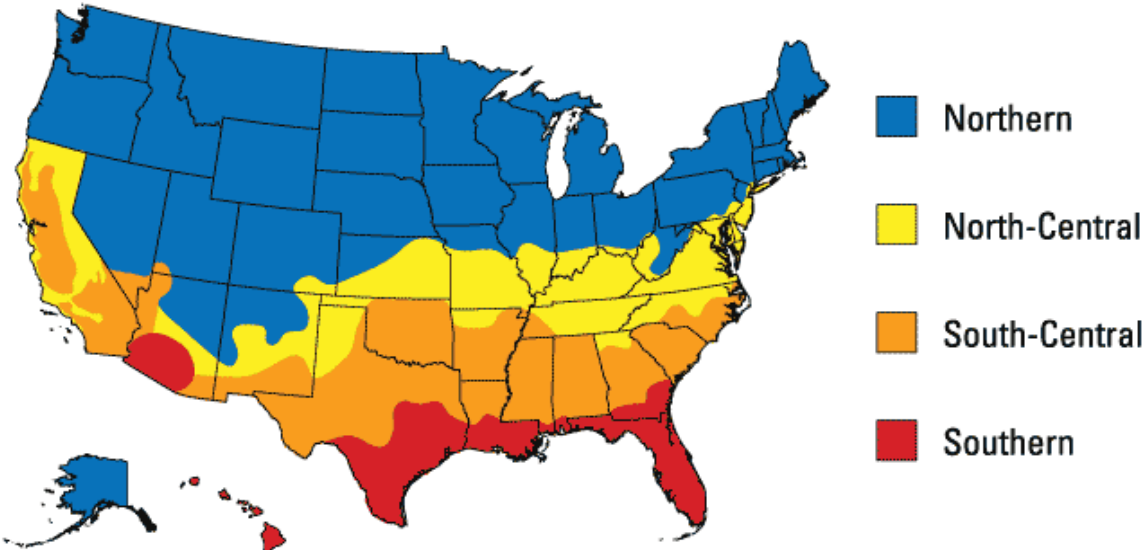

Windows

| Climate Zone | U-Factor ¹ | SHGC ² | |
|---------------|-----------------------|-------------------|-------------------------------|
| Northern* | ≤ 0.27 | Any | Prescriptive |
| | = 0.28 | ≥ 0.32 | Equivalent Energy Performance |
| | = 0.29 | ≥ 0.37 | |
| | = 0.30 | ≥ 0.42 | |
| North-Central | ≤ 0.30 | ≤ 0.40 | |
| South-Central | ≤ 0.30 | ≤ 0.25 | |
| Southern | ≤ 0.40 | ≤ 0.25 | |

Air Leakage ≤ 0.3 cfm/ft²

¹ Btu/h ft²·°F
² Solar Heat Gain Coefficient

* The effective date for the Northern Zone prescriptive and equivalent energy performance criteria for windows is January 1, 2016.

Doors

| Glazing Level | U-Factor ¹ | SHGC ² | |
|---------------|-----------------------|---------------------------|--------|
| Opaque | ≤ 0.17 | No Rating | |
| ≤ ½-Lite | ≤ 0.25 | ≤ 0.25 | |
| > ½-Lite | ≤ 0.30 | Northern North-Central | ≤ 0.40 |
| | | Southern South-Central | ≤ 0.25 |

Air Leakage for Sliding Doors ≤ 0.3 cfm/ft²
 Air Leakage for Swinging Doors ≤ 0.5 cfm/ft²

Performance Data

STRUCTURAL PERFORMANCE:

Direct Set Windows (not listed)

| Product | WDMA Hallmark CCL # | Rating | Size | Standard |
|--|---------------------|--------|---------|-------------------|
| 100 Wood Direct Set | - | PG50 | 72x72in | 101/I.S.2/A440-05 |
| 200 Cellular PVC Exterior / Wood Interior Direct Set | - | PG90 | 72x72in | 101/I.S.2/A440-05 |
| 300 Aluminum Clad Wood Direct Set | - | PG65 | 72x72in | 101/I.S.2/A440-05 |
| 300 Aluminum Clad Wood with Sash Set | - | PG60 | 72x72in | 101/I.S.2/A440-05 |

400 Series Aluminum Clad Wood Casement Picture

Hallmark CCL

| Product | WDMA Hallmark CCL # | Rating | Size | Standard |
|--|---------------------|----------------------------------|---------|----------------------------------|
| 400 Aluminum Clad Wood Casement Picture | 0830-H-001.00 | CW-PG35 | 72x72in | 101/I.S.2/A440-11 |
| 400 Aluminum Clad Wood Casement Picture-HP | 0830-H-001.01 | CW-PG50 | 72x72in | 101/I.S.2/A440-11 |
| 400 Aluminum Clad Wood Casement Picture-Impact | 0830-H-001.02 | CW-PG80 | 48x72in | 101/I.S.2/A440-11 |
| 400 Aluminum Clad Wood Casement Picture-Impact | 0830-H-001.03 | DP80 Missile D Wind Zone 4 | 48x72in | ASTM E-1996-12 ASTM E-1886-05 |
| 400 Aluminum Clad Wood Casement Picture-Impact | 0830-H-001.04 | DP80 | 48x72in | TAS 201/202/203-94 |

*Hallmark listing can be verified in WDMA's Hallmark Certified Products list, <http://www.wdma.amscert.com/>

Florida Product Approval

| Product | FL # | Rating | Size | Standard |
|--|---------|------------|---------|---|
| 400 Aluminum Clad Wood Casement Picture-Impact | 16796.1 | DP80, HVHZ | 48x72in | 101/I.S.2/A440-08 ASTM E-1886-05 ASTM E-1996-09 TAS 201/202/203-94 |
| 400 Aluminum Clad Wood Casement Picture | 16796.2 | DP80 | 72x72in | 101/I.S.2/A440-08 TAS 201-94 |

*Florida approval number can be verified on Florida Building Code Online, <http://www.floridabuilding.org/>

Performance Data

STRUCTURAL PERFORMANCE:

500 Series Aluminum Clad Commercial Outswing Door

Hallmark CCL

| Product | WDMA Hallmark CCL # | Rating | Size | Standard |
|--|---------------------|----------------------------------|----------|----------------------------------|
| 500 Aluminum Clad Wood Outswing Door-Fixed | 0830-H-002.00 | LC-PG50 | 37x96in | 101/I.S.2/A440-11 |
| 500 Aluminum Clad Wood Outswing Door-Side Hinged | 0830-H-002.01 | LC-PG50 | 74x96in | 101/I.S.2/A440-11 |
| 500 Aluminum Clad Wood Outswing Door-Mull | 0830-H-002.02 | LC-PG50 | 96in | 101/I.S.2/A440-11 |
| 500 Aluminum Clad Wood Outswing Door-Impact-Fixed | 0830-H-002.04 | LC-PG50 | 37x96in | 101/I.S.2/A440-11 |
| 500 Aluminum Clad Wood Outswing Door-Impact-Side Hinged | 0830-H-002.03 | LC-PG50 | 74x96in | 101/I.S.2/A440-11 |
| 500 Aluminum Clad Wood Outswing Door-Impact-Mull | 0830-H-002.05 | LC-PG50 | 96in | 101/I.S.2/A440-11 |
| 500 Aluminum Clad Wood Outswing Door-Impact-Fixed | 0830-H-002.06 | DP50 Missile D Wind Zone 4 | 37x96in | ASTM E-1996-12 ASTM E-1886-05 |
| 500 Aluminum Clad Wood Outswing Door-Impact-Side Hinged | 0830-H-002.07 | DP50 Missile D Wind Zone 4 | 74x96in | ASTM E-1996-12 ASTM E-1886-05 |
| 500 Aluminum Clad Wood Outswing Door-Impact-Mull | 0830-H-002.08 | DP50 Missile D Wind Zone 4 | 96in | ASTM E-1996-12 ASTM E-1886-05 |
| 500 Aluminum Clad Wood Outswing Door-Impact | 0830-H-002.09 | DP50 Missile D Wind Zone 4 | 111X96in | TAS 201/202/203-94 |
| 500 Aluminum Clad Wood Outswing Door-Impact, Rim Device and ADA Sill | 0830-H-002.10 | DP50 Missile D Wind Zone 4 | 74X96in | TAS 201/202/203-94 |

*Hallmark listing can be verified on WDMA's Hallmark Certified Products list, <http://www.wdma.amscert.com/>

Florida Product Approval

| Product | FL # | Rating | Size | Standard |
|---|---------|------------|----------|---|
| 500 Aluminum Clad Wood Outswing Door | 16795.1 | DP50 | 111X96in | 101/I.S.2/A440-08 TAS 201-94 |
| 500 Aluminum Clad Wood Outswing Door-Impact | 16795.2 | DP50, HVHZ | 111X96in | 101/I.S.2/A440-08 ASTM E-1886-05 ASTM E-1996-09 TAS 201/202/203-94 |

*Florida approval number can be verified at Florida Building Code Online, <http://www.floridabuilding.org/>

Finishing Guide for your FrontLine® Bldg. Products Inc. Door

Prior to installation, care must be taken to ensure the timeless beauty and weatherable durability of your new FrontLine door product. The most important item to remember is your door should be finished prior to being placed into service or immediately thereafter. This includes all interior and exterior wood surfaces. Failure to do so will void any written or implied warranties and may diminish the life expectancy of your purchased product.

Determining a finish and its application:

- The primary purpose of finishing, other than aesthetics, is to protect the wood components against moisture. It is for this reason that a high quality finish should be selected.
- The characteristics of wood vary within a given species. Included are color variation, wood grain patterns and ability to accept finish. These characteristics should be taken into consideration when selecting a method for finishing.
- Color should also be considered when determining a finish. Darker colors absorb a great deal more heat than lighter color. Because of this, doors finished in a darker finish and subjected to the sun's exposure will tend to shrink and swell a great deal more than those finished in a lighter color. This could cause mating surfaces to separate allowing moisture to migrate to unfinished surfaces. This is not a manufacturer's defect.

It is recommended that you contact a finish supplier for recommendations on types of topcoat finishes and preparatory finishes that should be utilized, prior to application of paints, stains or any other finishes.

Preparation prior to finishing should include:

- Removal of all hardware and weatherstrip (top and bottom sweep may remain).
- Lightly sanding surface of wood components. Depending on the wood and finish, the grit of sandpaper may vary. Typically a range of 150 to 220 is recommended. Avoid sanding top and bottom sweep. Sand in the direction of the wood's grain.
- Ensure all contaminants have been eliminated from the face of the surface to be finished. This may include dust, dirt, any moisture or oils that may have come into contact with the product's wood surfaces. Do not use any caustic or abrasive cleaners.



Interior Finishing

- Care must be taken when applying a finish to avoid contact with vinyl surfaces. Surfaces, such as some vinyl, may degrade when exposed to certain finishes.
- It is not recommended that a non-moisture barrier type finish be applied to any wood component. These included Tung oil, Danish oil or any type of penetrating oil. These types of products allow moisture to penetrate, exposing the wood to possible deterioration, rot, delamination or warping.
- Apply finishes as specified by the manufacturer, paying close attention to recommended dry times between each application. Sand lightly and clean surfaces with tack cloth between each coat. Make sure to apply finishes in a ventilated area.

Exterior Finishing

- Follow recommendation listed above, including those laid out in "Interior finishing".
- Exterior wood surfaces must be finished immediately to prevent damage from the outside environment. Ensure the finish is adequately applied to all visible as well as covered or overlapping surfaces. This includes holes bored into a face of the door for hardware and in the gap created at the end of each bar adhered to the face of the glass.
- Apply at least two coats of a selected finish.
- The wood portion of the sill must be finished in the same manner as specified above. It is recommended that at least two coat of a marine grade polyurethane be applied.

Maintenance

- Periodic inspection of your door must be performed. This is especially critical for the sill. The time between inspections will vary, depending on the region of the country your product has been placed into service. Re-apply finish coat as required.
- Consult finish manufacturer for recommendations on cleaning finished surfaces.



Installation Instruction

The following instructions are applicable for the following products: Aluminum Clad Wood, Wood and Cellular PVC.

Important: Read the following documentation completely prior to attempting any installation of your FrontLine product.

These instructions do not address all possible installation options that may exist. The installer is responsible for determining whether the following instructions meet or exceed requirements previously established by local codes and/or ordinances, which supersede these instructions. For installations other than those referenced in this document, you may refer to ASTM E2112, "Standard Practice for installation of Exterior Windows, Doors and Skylights" or consult with a local contractor, structural engineer, or architect.

Several items will be required for the installation of your FrontLine product. The most important items are appropriate eye, hearing and hand protection. Below is a check list of items which may be required for your unit's installation:

| Item | Item | Item |
|--------------------|---------------------|----------------------------|
| Eye Protection | Square | Shims |
| Hearing Protection | Drill | Fasteners |
| Gloves | Utility Knife | Flashing |
| Hammer | Level | Rags/Paper Towel |
| Putty Knife | Tape Measure | Fiberglass Insulation |
| Pry Bar | Sealant & Caulk Gun | Low Expand Foam Insulation |

When installation includes disturbing materials in place, prior to 1978, care must be taken with their removal. These materials may contain contaminants, such as lead, which are harmful when disturbed. The EPA has created guidelines to follow when performing any remodeling activity. The guidelines can be reviewed on the EPA website at www.epa.gov/lead. Included on the website is information on removal, recycling and/or disposal of contaminated materials.

Preparing the rough opening (opening window/door unit will be set into):

1. Check the rough opening to ensure it is plumb, square and level. Check dimensions in width, height and diagonally (Fig. 1). Check the width and height for plumb at three locations; each side of the rough opening and along the sill (Fig. 1).
2. It is recommended that an air barrier be applied to the building envelope as per ASTM E2112 guidelines.
3. Apply a self-sealing adhesive membrane flashing to the sill of the rough opening (Fig. 2). Cut the flashing long enough to extend an equal distance beyond the jamb flashing.



Fig. 1

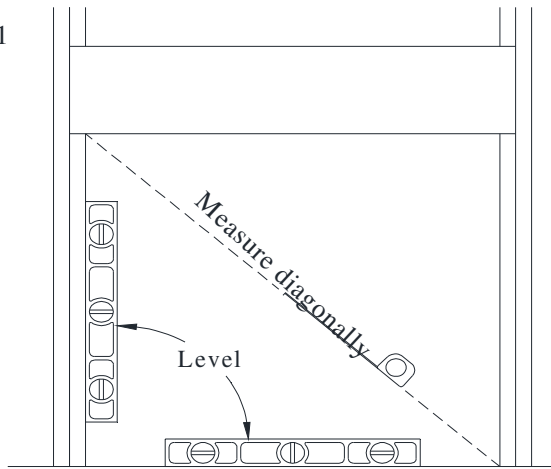
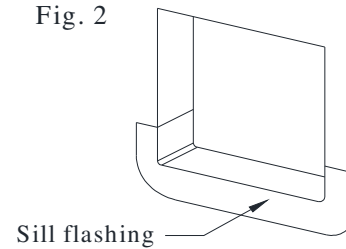
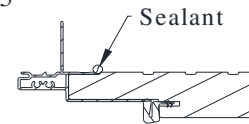

Fig. 2



Sill flashing

Fig. 3



Perimeter Flashing:

There is a multitude of practices and procedure for properly flashing a window/door unit. It is the installers responsibility to determine the best installation practice which may be "regionally specific" in its' suitability. A general approach to flashing around the perimeter of your FrontLine product can be found on flashing manufacturer's websites. One such site is at:

http://www2.dupont.com/Tyvek_Weatherization/en_US/tech_info/install.html

Installing the unit:

3. Before setting the product into the rough opening, a bead of sealant must be applied to bridge the outside perimeter edge of the frame cladding to the side of the wood jamb (Fig 3). This includes sealing the sheet metal plate, covering the back side of each of the hinge screw locations, to the frame. A continuous 1/4" diameter bead of sealant must also be applied to the back side of the nail fin/brickmould, around the perimeter of the unit. Sealant must be Grade NS Class 25 per ASTM C920.
4. Install the window, shimming and adjusting to square, plumb and level. Check the center width and height, to avoid bowing.
5. Fasten through the nail fin on aluminum clad wood products and through the brickmould and sill nose on wood or cellular PVC products with galvanized nails. Ensure the fasteners are long enough to penetrate the building envelope framing by 1" minimum, spaced no closer than 3" from each corner and 8" to 10" apart thereafter.

Perimeter Insulation:

10. Insulate from the home's interior, around the perimeter edge of the window/door frame, in the void created by the window/door frame and rough opening. Pack the insulation loosely. Some building codes require foam type insulation to form an air infiltration eliminating seal. Use only low expansion type foam in combination with fiberglass insulation. Foam and foam application must conform to ASTM E2112. Follow all instructions and warnings specified by the foam manufacturer.

11. After the siding is installed, apply a continuous bead of sealant around the perimeter of the window which meets Grade NS Class 25 per ASTM C920.

Outswing Door

(Optional, half saddle ADA sill) Setting block application

Prior to installing your door into the rough opening, apply the provided setting block. The block is located in the installation packet included with your FrontLine door unit. The size and location of block can be modified to fit your installation requirements, which may vary depending on the sill and/or sill placement. Determine the size which best suites your application and apply to the base of the door jamb. Secure block to the base of each jamb.

Sealing at Sill

Additional steps must be taken when installing an Outswing door. Special attention must be made when preparing the rough opening and sealing below the sill. If the sill is to extend past the plane of the building envelope's exterior sheathing, a solid surface must be available to provide support. Prior to setting the door unit in place, sealant must be applied along the rough opening's sill. Apply one ¼" diameter bead of sealant in line with nail fin/ exterior sheathing plane. Run an additional ¼" diameter bead 1 ½" in from the first. The second bead should meet up with the first, at the lower inside corners of the rough opening. After the unit has been set in place and secured to the rough opening, seal the void below the nail fin, in between the end of the sill and rough opening frame. Back-up (foam backer rod) may be required to fill any void prior to sealing.

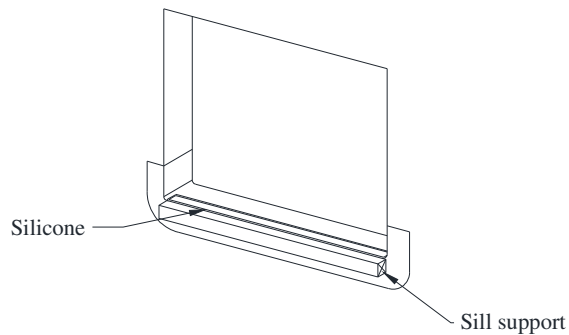

Securing at Hinge

Following the installation of the frame into the rough opening, secure the hinge through the wood jamb into the rough opening. Shims must be located at each hinge location. Remove the silver colored jamb hinge screw, provided to temporarily secure the hinge leaf for shipping. Inject sealant into each of the two jamb hinge screw holes. Using the #12 x 3" screws, provided with your installation packet, secure the hinge and jamb to the rough opening. Repeat this step for all remaining hinge screws.

FrontLine® Bldg. Products Inc. Light Commercial Door & Glass Limited Warranties

Limited Warranties

This document applies to the following separate, limited warranties (each a "Limited Warranty" or collectively the "Limited Warranties") as to the Doors, Insulated Glass, Decorative Glass, and Exterior Painted Aluminum Surfaces:

Doors

To the extent and in the manner provided herein, Frontline Bldg. Products Inc. ("FLB") warrants to the original purchaser of its FRONTLINE® brand Light Commercial Door product (the "Door") will be free from manufacturing defects in materials and workmanship for a period of **ten (10) years** from the date of manufacture by FLB; provided, however, FLB does not warrant the quality or condition of Doors sold with open frames (i.e., no glass) and such products are sold "**AS IS**" and "**WITH ALL FAULTS.**"

Doors Sold with Glass

The Doors which are sold without open frames (i.e., including installed glass) are subject to the limited warranty for the Door specified above, except that the installed glass included in the Doors sold without open frames is subject to one or more of the following limited warranties applicable to the installed glass:

Insulated Glass

The insulated glass utilizing a stainless steel spacer channel used in the Doors other than Decorative Glass as defined below) (the "Insulated Glass") shall be free from manufacturing defects in materials and workmanship causing seal failure for a period of **twenty (20) years** from the date of manufacture of the Door.

Decorative Glass & Custom Ordered Glass

Decorative glass and/or custom ordered glass installed by FLB in the Doors (the "Decorative Glass") shall be free from manufacturing defects in materials and workmanship causing seal failure for a period of **ten (10) years** from the date of manufacture of the Door .



Exterior Painted Aluminum Surfaces

The paint on the exterior aluminum cladding of the Door will not flake, crack, peel or check for ten (10) years from the date of manufacture of the Door, under normal conditions and subject to normal wear and tear.

Warp

Doors less than 3'0" in width and 7'0" in height are warranted against warping greater than 1/4" when properly installed and maintained for a period of one year from the date of manufacture of the Door. Door greater than 3'0" in width and 7'0" in height are not warranted against warping unless they have an FLB factory-installed multipoint locking mechanism, in which case such Door greater than 3'0" in width and 7'0" in height are subject to the same warranty against warping as found in the immediately preceding sentence.

General Statements

The following general statements apply to all Limited Warranties and other statements in this document:

- Any Limited Warranty applies only to the original purchaser of the applicable product from FLB (the "Original Purchaser") .
- The Original Purchaser must supply proof of purchase to FLB with any warranty claim.
- All warranties provided by component manufacturers to FLB, if any, are hereby assigned by FLB to the Original Purchaser.
- If a warranty claim arises during the applicable warranted period for any of the Limited Warranties set forth herein, Original Purchaser's sole and exclusive remedy is that FLB will, at the sole election of FLB:
 - Repair the defective product;
 - Replace the defective product;
 - Reperform defective services; or
 - Refund the purchase price for the defective product.

THE REPAIR, REPLACEMENT, REPERFORMANCE, OR REFUND AT FLB'S ELECTION AS DESCRIBED HEREIN SHALL BE THE SOLE AND EXCLUSIVE REMEDY WITH RESPECT TO ANY AND ALL CLAIMS PRESENTED UNDER ANY OF THE LIMITED WARRANTIES.

If FLB elects to provide replacement product for defective product, the replacement parts may be the current product being manufactured at that time. FLB will not be responsible for any costs of shipping, handling, installation, removal, reinstallation, labor, finish painting, or other incidentals related to the new or the defective product.

- The Limited Warranties shall be void and of no effect based on or in the event of:
 - Improper installation, improper maintenance, or misuse;
 - Used or installed in a structure not used for commercial purposes or not a multifamily dwelling of five stories or less;
 - Condensation, frost or mold caused by excess humidity;
 - Chips or other breakage, stress cracks, or slope glazing;
 - Installation or use in mobile vehicles, mobile homes, or commercial refrigeration;
 - Structural defects or settling of the structure in which the product is placed.



- Corrosion or any finish failures of aluminum cladding or all-aluminum frame components due to environmental conditions such as salt spray, acid rain or other corrosive substances;
- Applications or use in seacoast areas due to corrosion;
- Conditions or use exceeding design standards;
- Natural disasters or casualty losses, including, without limitation, fire, flood, hurricane, typhoon, tornado, or other natural disasters or casualty losses;
- Installation in a face barrier system or exterior insulation finish system (EIFS) using stucco, or synthetic stucco;
- Glass breakage or seal failure at locations above 3,500 feet above sea level, if product is not ordered with a breather or capillary tube system;
- Prolonged or excessive exposure to moisture or ground.
- Installation or use in sauna, swimming pool or hot tub rooms or other rooms with high humidity conditions;
- Application of after-market tints, films or coatings applied to glass surfaces;
- Variance of color, grain or texture of wood, and normal wear or discoloration of interior or exterior finishes;
- Cracked or broken glass or damage to product resulting from an accident, abuse, misuse, on-site construction, location at or adjacent to airports, alteration of any product, shattering due to heat build-up, or any cause beyond the control of FLB;
- Damage caused by power washing, brick washing, acidic washing, or application or exposure to any chemicals, chemical fumes, or harsh or corrosive substance or environments (including, but not limited to, salt spray, airborne pollutants, mortar, mortar cleaner or alkali hydroxides);
- Improper painting, staining, or field finishing maintenance of wood surfaces;
- Failure to apply a good quality coating system to bare wood surfaces within 30 days after purchase.
- Installation of products in applications or environmental conditions above certified performance levels or exceeding design standards.

- **IN NO EVENT SHALL FLB BE LIABLE FOR ANY DIRECT, INDIRECT, SPECIAL, INCIDENTAL OR CONSEQUENTIAL DAMAGES OR LOSSES, INCLUDING, WITHOUT LIMITATION, COSTS OF SHIPPING, HANDLING, INSTALLATION, REMOVAL, REINSTALLATION, FINISH PAINTING, OR OTHERWISE. IN NO EVENT SHALL THE AMOUNT DUE HEREUNDER BE IN EXCESS OF THE DEFECTIVE UNIT'S PURCHASE PRICE, WHETHER THE CLAIM IS FOR BREACH OF WARRANTY OR NEGLIGENCE OR OTHERWISE. SOME STATES DO NOT ALLOW FOR THE EXCLUSION OR LIMITATIONS OF INCIDENTAL, CONSEQUENTIAL OR INDIRECT DAMAGES OR LOSSES, OR A CAP ON RECOVERY, SO THIS LIMITATION MAY NOT APPLY TO YOU.**
- **TO THE MAXIMUM EXTENT ALLOWED BY THE LAW, THE LIMITED WARRANTIES AS EXPRESSLY SET FORTH HEREIN ARE IN LIEU OF ALL OTHER EXPRESS OR IMPLIED WARRANTIES OF ANY KIND, INCLUDING, BUT NOT LIMITED TO, IMPLIED WARRANTIES OF MERCHANTABILITY OR FITNESS FOR A PARTICULAR PURPOSE, AND ALL SUCH IMPLIED WARRANTIES ARE HEREBY DISCLAIMED. HOWEVER, SOME STATES DO NOT ALLOW LIMITATIONS ON HOW LONG AN IMPLIED WARRANTY LASTS, SO THIS LIMITATION MAY NOT APPLY TO YOU.**

Warranty Claims

If you wish to make a warranty claim under any of the Limited Warranties herein, the claimant must contact FLB at the following address, providing the proof of purchase, specifying the building address the allegedly defective product is located, and a reasonably detailed description of the alleged defect:

FrontLine Bldg. Products Inc.

Attention: Warranty Claims

610 Jensen Drive

Medford, WI 54451

Phone – 715-748-2288

Any claims under any Limited Warranty must be made in writing to FLB at the above address within thirty (30) days of discovery of the issue giving rise to the claim and must relate to claims arising during the applicable warranty period.

If FLB determines in its sole discretion that an investigation of any warranty claim under any Limited Warranty is necessary, the claimant must allow access to a representative of FLB to view the property and the product specified in the claim, including the taking of photographs and gathering samples as required.



