

# PRE-CLAD PATIO DOOR FRAME



**FrontLine**<sup>®</sup>  
*Bldg. Products Inc.*  
Member of the Bay Family of Companies

# FrontLine® Pre-Clad Patio Door Frame

Introducing our **Pre-Clad Patio Door Frame**, designed and developed to utilize the standard entry door platform for flexibility, performance and cost.

The hinged French patio door frame allows fabricators to fill that premiere opening on every project, connecting the home to the ever growing outdoor living space that homeowners desire today.

This system can be used for single-family dwellings, as well as light commercial projects such as multi-family and condos. Offering a limited lifetime warranty.

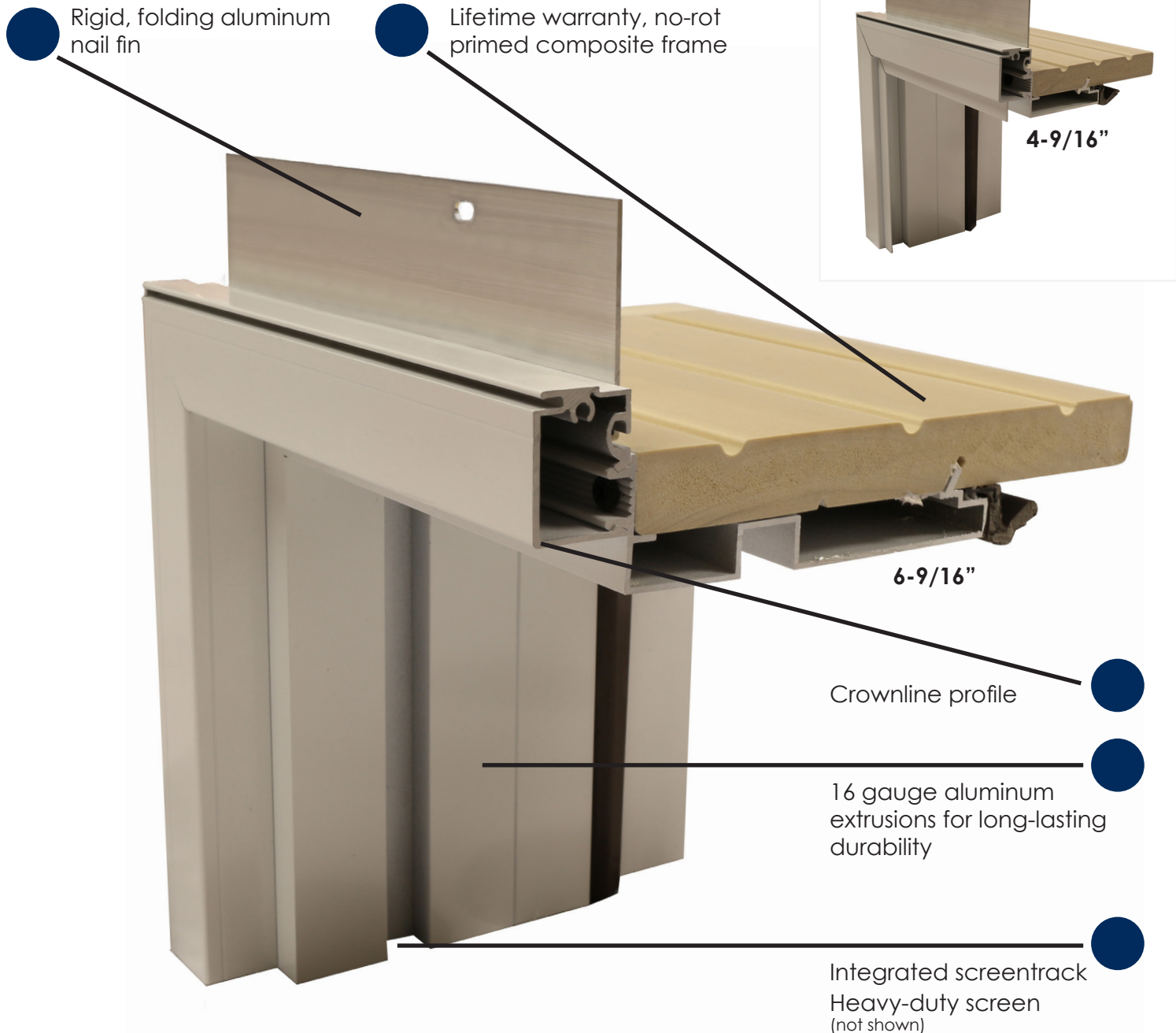

# Features

## Hinged Patio Door Units

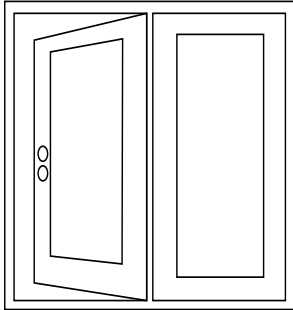

**Center Hinge  
Left Hand Active  
(viewed from exterior)**

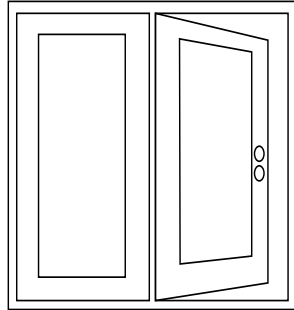

**Center Hinge  
Right Hand Active  
(viewed from exterior)**

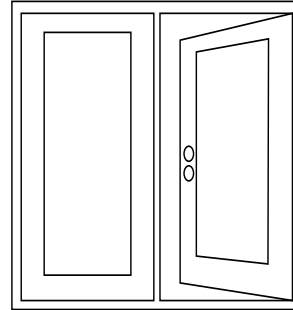

**Right Hand Jamb  
Hinge Active  
(viewed from exterior)**

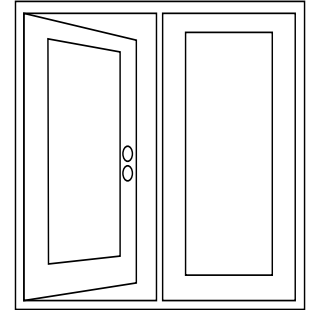

**Left Hand Jamb  
Hinge Active  
(viewed from exterior)**

### Sold as a Kit - Ready to Assemble

- Available up to 6/0 width and 6/6 to 8/0 height.
  - Pre-Clad 4-9/16" jamb with new integrated screen track on crownline nosing.
  - Pre-clad 6-9/16" jamb with new integrated screen track and standard crownline nosing.
  - 2-1/2" x 4-3/8" LVL-reinforced mull post with extruded aluminum cover for long-lasting durability and strength.
  - Cut and machined to each fabricator's specifications.
  - Heavy-duty extruded screen with fiberglass mesh.
- Rigid folding aluminum nail fin.
  - Five colors: White, Sandstone, Black, Bronze and Almond
  - TRU-LOC™ Installation Anchors (Box of 8)

### Limited Lifetime Warranty

### Add-on Options

- J-mould to achieve brickmould appearance.
- 3-1/2" flat casing
- 3-point lock
- Variable Depth Expander - For in between depths.

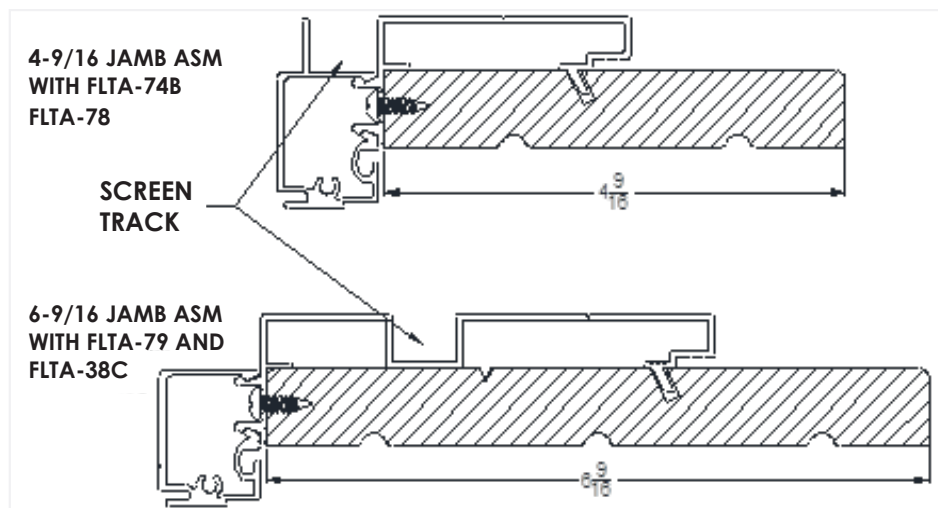

**We also offer these great products:**

Architectural Windows & Grilles

Commercial Entry Doors

Commercial Grilles

Custom Millwork

Entry Door Systems

Garage Door Frames

Transom Windows & Grilles

Oversized Direct Set Windows

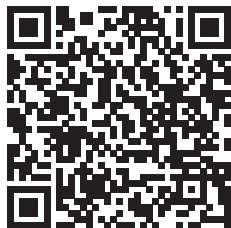

**Connect with Us**

 [www.frontlinebldg.com](http://www.frontlinebldg.com)

 [sales@frontlinebldg.com](mailto:sales@frontlinebldg.com)

 1-800-760-8941

