

* NOTE: FRAME CORNERS ATTACHED w/ (3) #9 X 3" DECK SCREWS @ HEAD & SILL (TYP.).

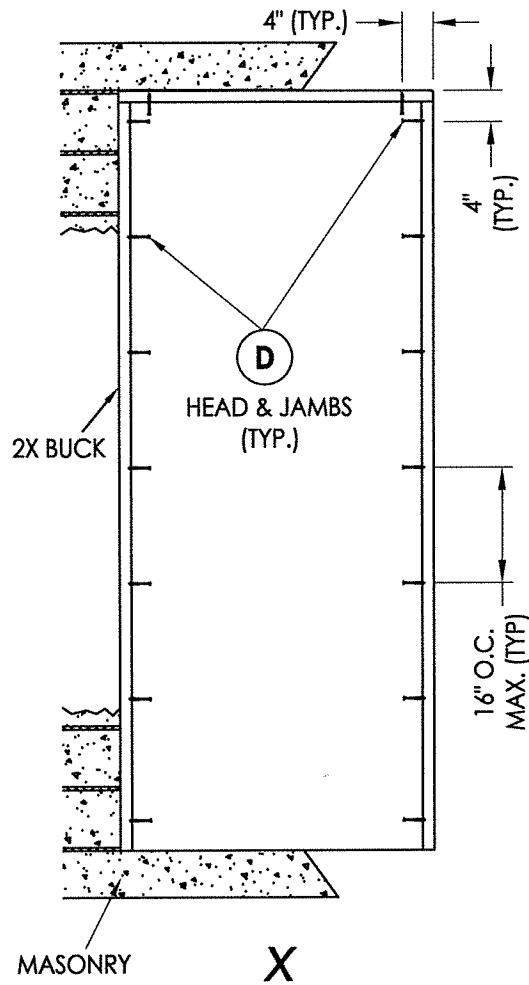

2X BUCK ANCHORING

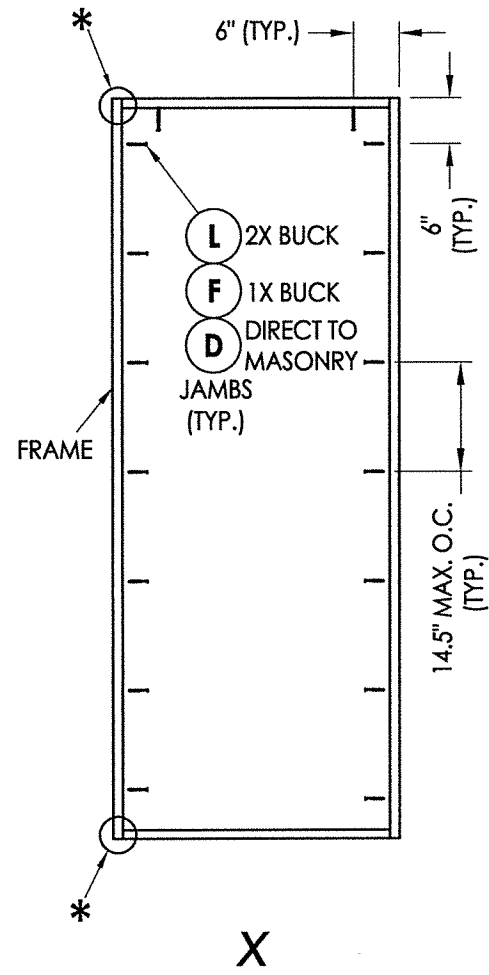

FRAME ANCHORING

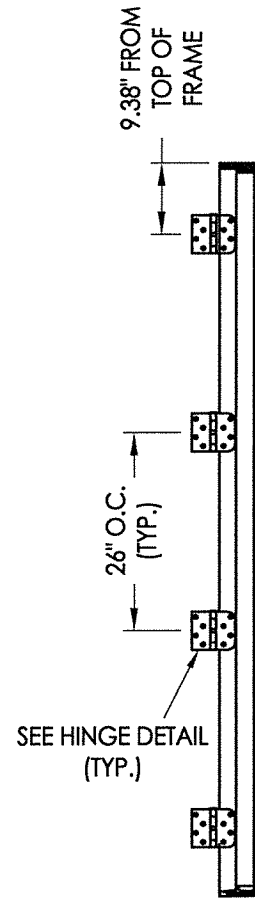

HINGE JAMB
8'-0" DOOR

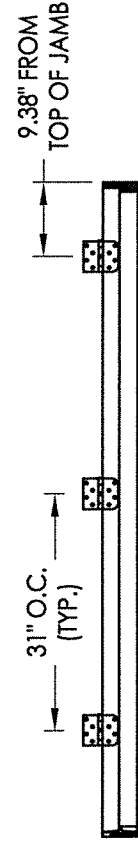

HINGE JAMB
7'-0" DOOR

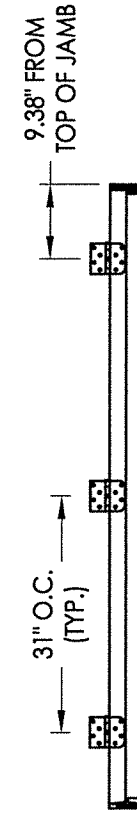

HINGE JAMB
6'-8" DOOR

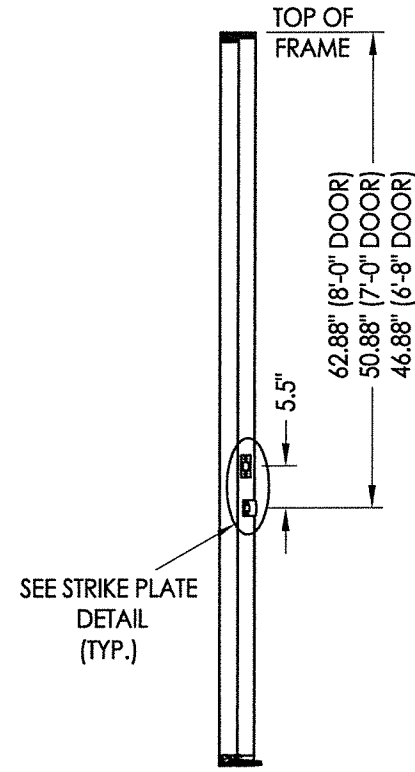

STRIKE JAMB

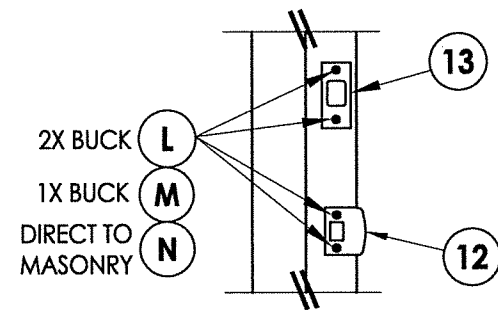

LATCH & DEADBOLT DETAIL

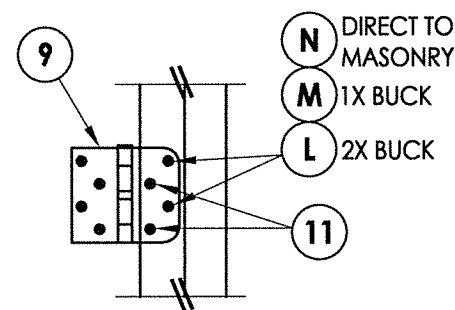

HINGE DETAIL
INSWING

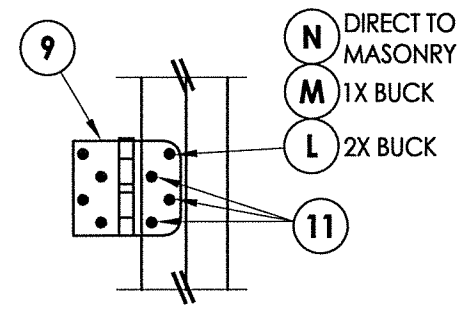

HINGE DETAIL
OUTSWING

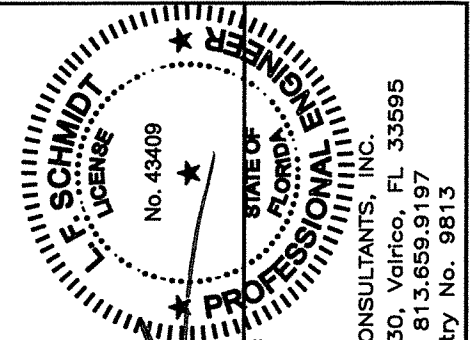

L.F. Schmidt
8-8-22

Documents Prepared By:
Lyndon F. Schmidt
P.E. No. 43409

R.W. BUILDING CONSULTANTS, INC.
P.O. Box 230, Valrico, FL 33595
Phone No.: 813.659.9197
FBPE Registry No. 9813

PRODUCT:	BMI COMPONENTS
PART OR ASSEMBLY:	BUCK & FRAME ANCHORING

NO.	DATE	BY	REVISIONS

DATE:	7/05/22
SCALE:	N.T.S.
DWG. BY:	LFS
CHK. BY:	RW
DRAWING NO.:	FL-41560.3
SHEET	5 OF 7

Z:\Clients\BMIA - Florida Product Approvals\FL-41560\C - Drawings\FL 41560 (2020)\FL-41560.3.dwg

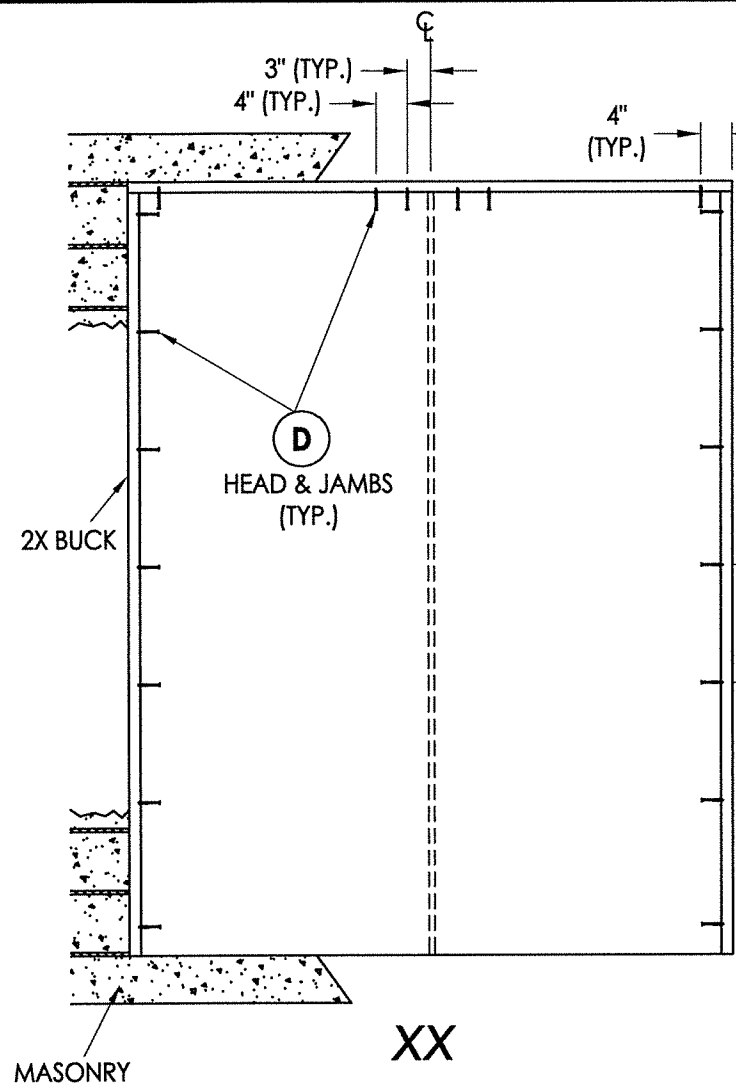

2X BUCK ANCHORING

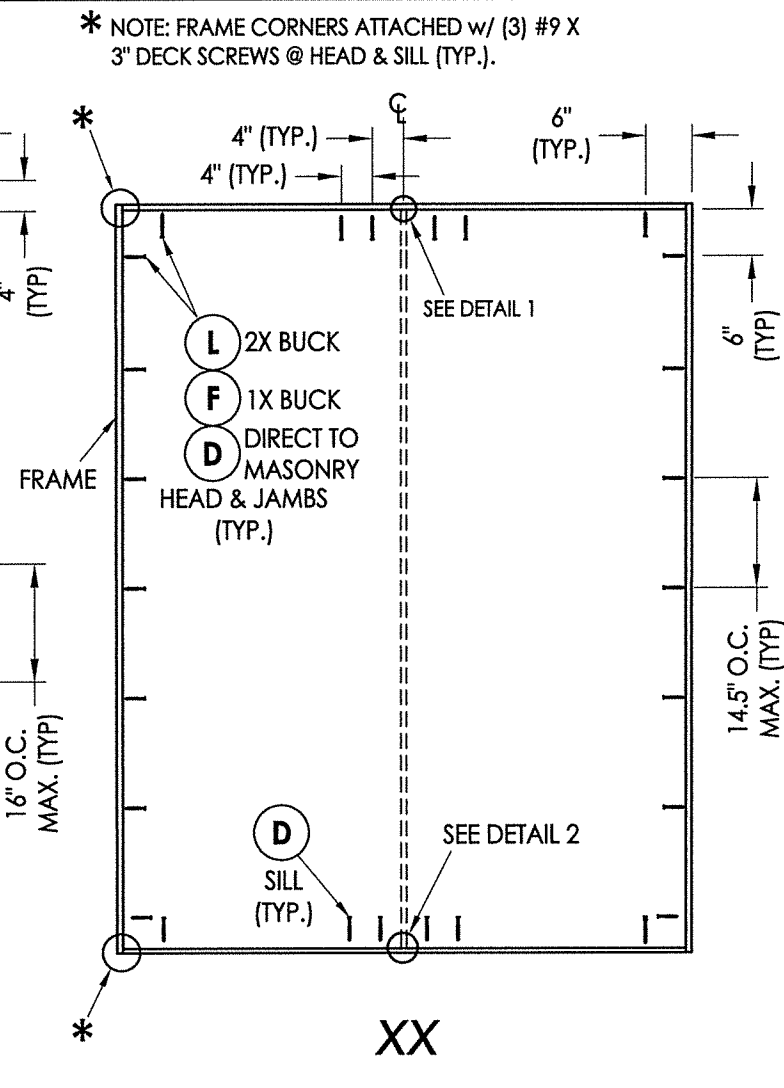

FRAME ANCHORING

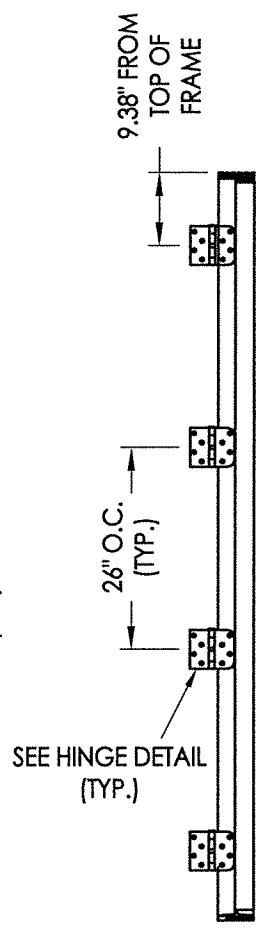

**HINGE JAMB
8'-0" DOOR**

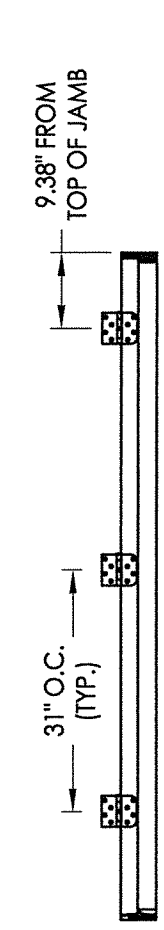

**HINGE JAMB
7'-0" DOOR**

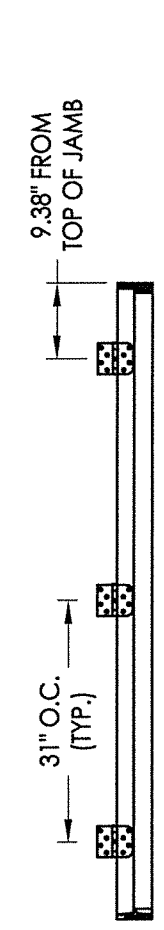

**HINGE JAMB
6'-8" DOOR**

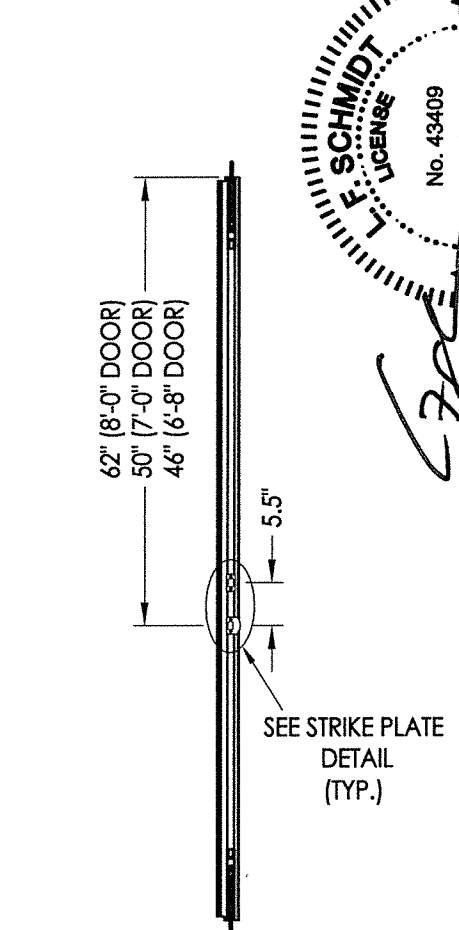

ASTRAGAL

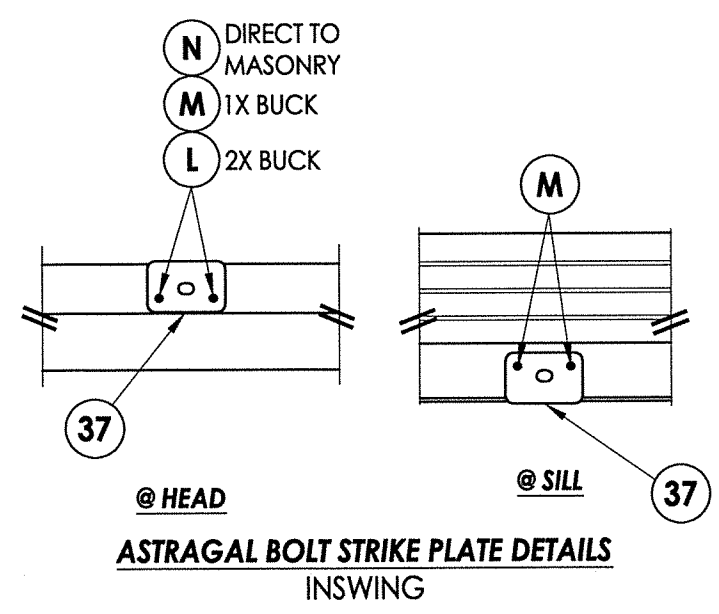

**ASTRAGAL BOLT STRIKE PLATE DETAILS
INSWING**

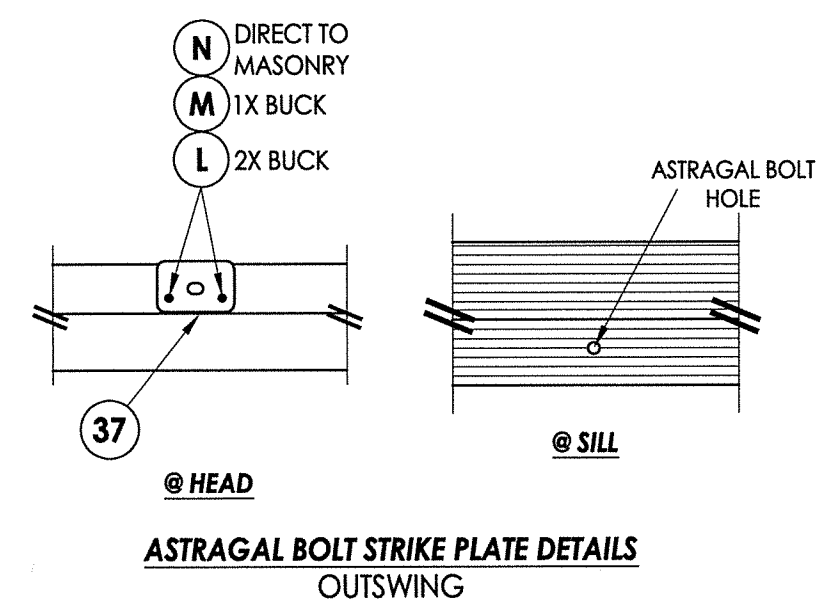

**ASTRAGAL BOLT STRIKE PLATE DETAILS
OUTSWING**

HARDWARE DETAILS

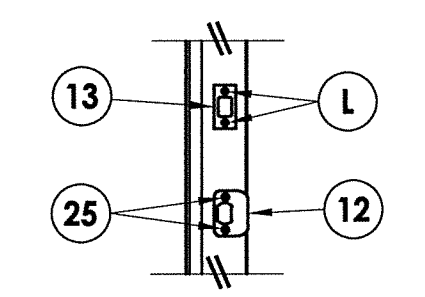

LATCH & DEADBOLT DETAIL

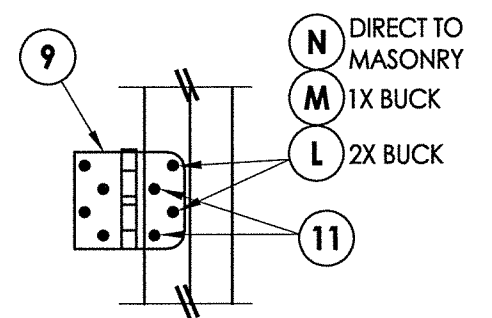

**HINGE DETAIL
INSWING**

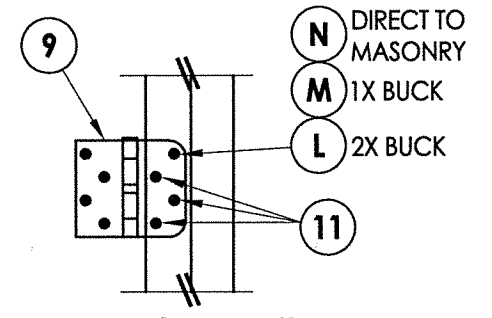

**HINGE DETAIL
OUTSWING**

* NOTE: FRAME CORNERS ATTACHED w/ (3) #9 X 3" DECK SCREWS @ HEAD & SILL (TYP.).

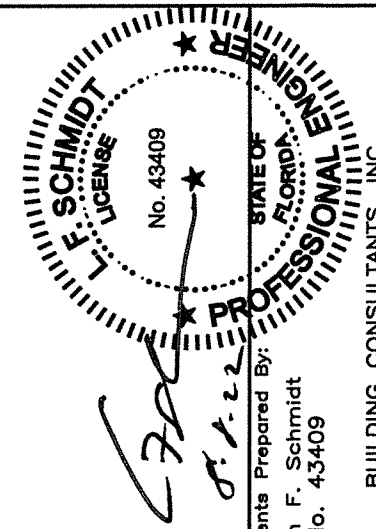

Documents Prepared By:
Lyndon F. Schmidt
P.E. No. 43409

R.W. BUILDING CONSULTANTS, INC.
P.O. Box 230, Valrico, FL 33595
Phone No.: 813.659.9197
FBPE Registry No. 9813

PRODUCT:	BMI COMPONENTS	
PART OR ASSEMBLY:	BUCK & FRAME ANCHORING	
NO.	DATE	BY
		REVISIONS
DATE:	7/05/22	
SCALE:	N.T.S.	
DWG. BY:	LFS	
CHK. BY:	RW	
DRAWING NO.:	FL-41560.3	
SHEET	6	OF 7

BILL OF MATERIALS

ITEM #	DESCRIPTION	MATERIAL
A	1X BUCK (G >= 0.42)	WOOD
B	2X BUCK (G >= 0.42)	WOOD
C	1/4" MAX. SHIM SPACE	-
D	1/4" X 2-3/4" PFH DeWALT OR ITW CONCRETE SCREW	STEEL
E	MASONRY - 3,000 PSI MIN. CONCRETE CONFORMING TO ACI 301 OR HOLLOW BLOCK CONFORMING TO ASTM C90	CONCRETE
F	1/4" X 3-3/4" PFH DeWALT OR ITW CONCRETE SCREW	STEEL
L	#10 X 2-1/2" PFH WOOD SCREW (1.15" MIN. EMB.)	STEEL
M	3/16" X 3-1/4" PFH ITW CONCRETE SCREW	STEEL
N	3/16" X 2-1/4" PFH ITW CONCRETE SCREW	STEEL
1	HEAD & SIDE JAMB (BMI WPC)	COMP
7	WEATHERSTRIP	FOAM
8	SWEEP	VINYL
9	4" X 4" HINGE	STEEL
11	#9 X 3/4" PFH WOOD SCREW	STEEL
12	LATCH STRIKE PLATE	STEEL
13	DEADBOLT STRIKE PLATE	STEEL
25	#8 X 2-1/2" PFH WOOD SCREW	STEEL
37	ASTRAGAL STRIKE PLATE	STEEL
40	DOOR PANEL (BY OTHERS - SEE GENERAL NOTE 4, SHEET 1)	-

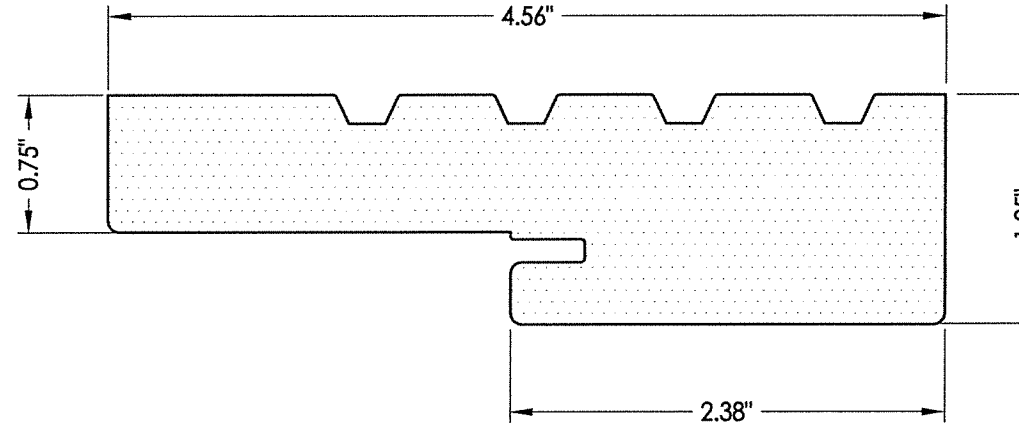

1 **WOOD PLASTIC COMPOSITE JAMB**
BMI

CONCRETE ANCHOR NOTES:

- Concrete anchor locations at the corners may be adjusted to maintain the min. edge distance to mortar joints.
- Concrete anchor locations noted as "MAX. ON CENTER" must be adjusted to maintain the min. edge distance to mortar joints, additional concrete anchors may be required to ensure the "MAX. ON CENTER" dimension are not exceeded.
- Concrete anchor table:

ANCHOR TYPE	ANCHOR SIZE	MIN. EMBEDMENT	MIN. CLEARANCE TO MASONRY EDGE	MIN. CLEARANCE TO ADJACENT ANCHOR
ITW BUILDEX TAPCON®	3/16"	1-1/4"	3"	1-1/2"
	1/4"	1-1/4"	2"	4"
DeWALT ULTRACON®	1/4"	1-1/4"	1"	4"

WOOD SCREW INSTALLATION NOTES:

- Maintain a minimum 5/8" edge distance, 1" end distance, & 1" o.c. spacing of wood screws to prevent the splitting of wood.

Documents Prepared By:
 Lyndon F. Schmidt
 P.E. No. 43409

R.W.
 BUILDING CONSULTANTS, INC.
 P.O. Box 230, Valrico, FL 33595
 Phone No.: 813.659.9197
 FBPE Registry No. 9813

PRODUCT:	BMI COMPONENTS
PART OR ASSEMBLY:	BILL OF MATERIALS & COMPONENTS
DATE:	7/05/22
SCALE:	N.T.S.
DWG. BY:	LFS
CHK. BY:	RW
DRAWING NO.:	FL-41560.3
SHEET	7 OF 7